

# 计算传热学的近代进展

## 第三章 压力与速度耦合算法研究进展



主讲 陶文铨

西安交通大学  
能源与动力工程学院  
热流科学与工程教育部重点实验室  
2024年4月30日, 西安

## 第3章 压力与速度耦合算法研究进展

### 3.1 SIMPLE系列算法的基本思想

### 3.2 PISO算法与CLEAR算法介绍

---

### 3.3 IDEAL算法

### 3.4 FVM中松弛因子的自动取值方法

### 3.5 FVM中的同位网格

### 3.6 非结构化网格上流场的求解

---

### 3.7 SIMPLE系列算法向可压缩流的发展

## 3.1 SIMPLE系列算法的基本思想

3.1.1 二维交叉网格上流场控制方程的离散及其求解

3.1.2 压力修正算法的基本思想及两个重要假设

3.1.3 SIMPLER与SIMPLEC算法

3.1.4 SIMPLEX算法

3.1.5 四种算法在密网格下收敛性的比较

3.1.6 压力修正算法是一种预估-校正算法

# 3.1 SIMPLE算法的基本思想

## 3.1.1 二维交叉网格上流场控制方程的离散及其求解

### 1. 方程及离散

$$\left\{ \begin{aligned} \frac{\partial u}{\partial x} + \frac{\partial v}{\partial y} &= 0 \\ \frac{\partial(uu)}{\partial x} + \frac{\partial(vu)}{\partial y} &= -\frac{1}{\rho} \frac{\partial p}{\partial x} + \nu \left( \frac{\partial^2 u}{\partial x^2} + \frac{\partial^2 u}{\partial y^2} \right) \\ \frac{\partial(uv)}{\partial x} + \frac{\partial(vv)}{\partial y} &= -\frac{1}{\rho} \frac{\partial p}{\partial y} + \nu \left( \frac{\partial^2 v}{\partial x^2} + \frac{\partial^2 v}{\partial y^2} \right) \end{aligned} \right.$$

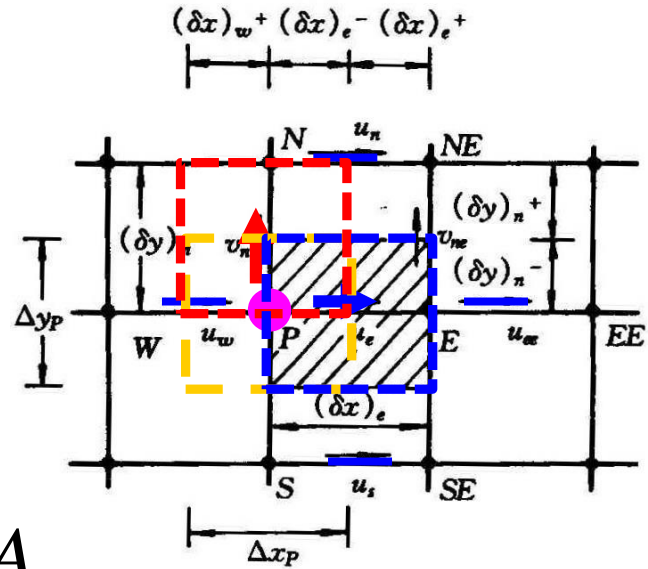

$$\left\{ \begin{aligned} a_e u_e &= \sum a_{nb} u_{nb} + b + (p_P - p_E) A_e \\ a_n v_n &= \sum a_{nb} v_{nb} + b + (p_P - p_N) A_n \\ [(\rho u)_e - (\rho u)_w] \Delta y + [(\rho v)_n - (\rho v)_s] \Delta x &= 0 \end{aligned} \right.$$

## 2. 离散方程的求解

**(1) 联立直接求解(coupled method):** 不存在任何压力与速度的耦合关系处理问题；以往但计算机内存容量的限制以及问题的非线性限制了此法的应用；但近期已经被纳入到商业软件中；

**(2) 分离式求解 (segregated method) :** 假设压力场  $p^*$ , 先解  $u$  方程, 再解  $v$  方程, 然后通过利用连续性方程来修正假定的压力, 使与修正后压力对应的速度满足连续性要求。**一般地**, 压力与速度的改进都通过加上一个小量来进行:  $p', u', v'$ 。

## 3.1.2 压力修正算法的基本思想及两个重要假设

### 1. 基本思想

- 1) 在流场迭代求解的每一个层次上，都必须满足连续性方程；
- 2) 在每一层次动量方程的求解中获得中间速度后对压力进行修正，使与修正后的压力， $p^*+p'$ ，相对应的速度， $u^*+u'$ ， $v^*+v'$ ，满足质量守恒要求。

### 2. 实施步骤

- 1) 假定一个速度场  $u^{(0)}$ ， $v^{(0)}$ ，计算  $a_e$ ， $a_n$ ， $a_{nb}$ ， $b$ 等；

2) 假定一个压力场  $p^*$ ; (简化假设1:  $p^*$ 独立设定)

3) 求解动量方程, 得出临时速度场  $u^*, v^*$ ;

4) 据  $u^*, v^*$ 修正压力, 获得修正分量 $p'$ , 要求与 $p'$ 对应的 $u', v'$ 使  $(u^*+u'), (v^*+v')$  满足质量守恒, 由此导出压力修正方程;

$$a_e(u_e^* + u_e') = \sum a_{nb}(u_{nb}^* + u_{nb}') + b + A_e[(p_P^* + p_P') - (p_E^* + p_E')]$$

$$\text{——} a_e u_e^* = \sum a_{nb} u_{nb}^* + b + A_e(p_P^* - p_E^*)$$

$$a_e u_e' = \sum a_{nb} u_{nb}' + A_e(p_P' - p_E')$$

略去邻点速度修正量的影响（**第二个简化假设**）可得：

$$u'_e = \frac{A_e}{a_e} (p'_P - p'_E) = d_e (p'_P - p'_E), \quad d_e = \frac{A_e}{a_e}$$

$$v'_n = \frac{A_n}{a_n} (p'_P - p'_N) = d_n (p'_P - p'_N), \quad d_n = \frac{A_n}{a_n}$$

**5) 获得  $p'$  后修正速度和压力；**

$$u_e = u_e^* + d_e (p'_P - p'_E) \quad v_n = v_n^* + d_n (p'_P - p'_N) \quad p = p^* + \alpha_p p'$$

**6) 以  $u_e, v_n$  以及  $p^* + \alpha_p p'$  开始下一层次的迭代计算。**

### 3. 两个基本简化假设

**假设 1:  $p^*$  独立设定；**

**假设 2: 略去邻点速度修正量的影响。**



### 3.1.3 SIMPLER 与SIMPLEC算法

#### 1.SIMPLER (1980) 完全克服了第一个简化假设

- 1) 假定一个速度场  $u^{(0)}$ ,  $v^{(0)}$ , 计算  $a_e, a_n, a_{nb}, b$  等;
- 2) 由假定的速度  $u^{(0)}$ ,  $v^{(0)}$ , 计算假拟速度  $u, \tilde{v}$ , 进而根据质量守恒导出一个压力方程, 以确定  $p^*$ ;

(完全克服了简化假设1) ;

$$u_e = \sum \frac{a_{nb} u_{nb}^0 + b}{a_e} \quad \tilde{v}_n = \sum \frac{a_{nb} v_{nb}^0 + b}{a_e}$$

$$a_P p_P = a_E p_E + a_W p_W + a_N p_N + a_S p_S + b$$

$$b = \frac{(\rho_P^0 - \rho_P) \Delta x \Delta y}{\Delta t} + [(\rho u)_w - (\rho u)_s] A_e + [(\rho \tilde{v})_s - (\rho \tilde{v})_n] A_n$$

- 3) 求解动量方程，得出临时速度场  $u^*$ ,  $v^*$ ;
- 4) 据  $u^*$ ,  $v^*$ 修正压力，获得修正分量  $p'$ , 要求与  $p'$  对应的  $u', v'$  使  $(u^*+u'), (v^*+v')$  满足质量守恒，由此导出压力修正方程（同**SIMPLE**）；
- 5) 获得  $p'$ 后修正速度，**但不修正压力**；

$$u_e = u_e^* + d_e(p'_P - p'_E) \quad v_n = v_n^* + d_n(p'_P - p'_N)$$

- 6) 以  $u_e, v_n$  开始下一层次的迭代计算。

## 2. SIMPLEC减轻了第二个简化假设的影响 (1984)

- 1) 假定一个速度场;
- 2) 假定一个压力场;
- 3) 求解动量方程;

完全同SIMPLE

### 4) 与SIMPLE有区别:

在速度修正量方程两边各减去  $\sum a_{nb}u'_e$  得:

$$a_e u'_e - \sum a_{nb} u'_e = \sum a_{nb} u'_{nb} - \sum a_{nb} u'_e + A_e (p'_P - p'_E)$$

$$u'_e (a_e - \sum a_{nb}) = \sum a_{nb} (u_{nb} - u'_e) + A_e (p'_P - p'_E)$$

可以认为： $u'_e, u'_{nb}$  具有相同的量级，因而略去  $\sum a_{nb}(u'_{nb} - u'_e)$  而造成的影响比**SIMPLE**中略去  $\sum a_{nb}u'_{nb}$  而造成的影响要小得多。于是有：

$$u'_e(a_e - \sum a_{nb}) = A_e(p'_P - p'_E)$$

$$u'_e = \left( \frac{A_e}{a_e - \sum a_{nb}} \right) (p'_P - p'_E), \text{ 类似的有 } v'_n = \left( \frac{A_n}{a_n - \sum a_{nb}} \right) (p'_P - p'_N)$$

**SIMPLEC**  
中的de

$$d_e = \frac{A_e}{a_e - \sum a_{nb}}; d_n = \frac{A_n}{a_n - \sum a_{nb}}$$

**此即SIMPLEC中速度修正值计算式。**

5) 与SIMPLE有区别:  $p'$  不再亚松弛。

$$u'_e = d_e (p'_P - p'_E) = d_e \Delta p'_e \quad u = u^* + u'$$

$$v'_n = d_n (p'_P - p'_N) = d_n \Delta p'_n \quad v = v^* + v'$$

$$p = p^* + p'$$

6) 以  $u_e, v_n$  以及  $p^* + p'$  开始下一层次的迭代计算。

### 3.1.4 SIMPLEX算法 (1986)

SIMPLEC算法的实质性的一步是系数  $d$  的计算式的改进, 可以部分考虑邻点的影响; 由此推广开去: 如果能够形成一组关于计算  $d$  的方程, 使其能更多地考虑邻点的影响, 则有望加速收敛。

为此，将表达式  $u'_e = d_e(p'_P - p'_E) = d_e \Delta p'_e$

推广到：

$$u'_{nb} = d_{nb} \Delta p'_{nb}$$

代入到：  $a_e u'_e = \sum a_{nb} u'_{nb} + A_e (p'_P - p'_E)$

得  $a_e d_e \Delta p'_e = \sum a_{nb} d_{nb} \Delta p'_{nb} + A_e \Delta p'_e$

假定： $\Delta p'_e = \Delta p'_{nb}$  (新的假定)

于是： $a_e d_e \Delta p'_e = \sum a_{nb} d_{nb} \Delta p'_{nb} + A_e \Delta p'_e$

得确定系数  $d$  的代数方程组： $a_e d_e = \sum a_{nb} d_{nb} + A_e$

根据已知的动量方程系数可以由此求出  $d$ 。边界条件是：

“绝热型” ---  $d$  方程的边界系数为0

得出上式时没有略去邻点的影响；**但是**引入了新的假定： $\Delta p'_e = \Delta p'_{nb}$  **因此也仅能部分克服第二个假设。**

SIMPLEX算法的计算步骤如下：

- (1) 假定速度初场  $u^0, v^0$ , 计算系数  $a, b$
- (2) 假定压力场  $p^*$ ；
- (3) 求解动量离散方程，得  $u^*, v^*$ ；
- (4) **求解  $d$  方程**，然后求解压力修正方程，得  $p'$ ；
- (5) 由  $p'$  修正速度，得  $u', v'$ ；
- (6) 以  $(u^*+u'), (v^*+v'), (p^*+p')$  作为本层次的速度场与压力，开始下一层次的迭代 ( **$p'$  不作亚松弛**)。

### 3.1.5 四种算法在密网格下收敛性的比较

| 算法      | 第一个简化假定                             | 第二个简化假定   |
|---------|-------------------------------------|---|
| SIMPLE  | $p^*$ 独立地假定, 通过修正量改进并亚松弛            | $\sum a_{nb} u'_{nb} = 0, d_e = A_e / a_e$  |
| SIMPLER | $p^*$ 由已知的速度算出, 克服第一个假定, 压力修正量不修正压力 | $\sum a_{nb} u'_{nb} = 0, d_e = A_e / a_e$  |
| SIMPLEC | $p^*$ 独立地假定, 通过修正量改进, 但压力的修正量不亚松弛   | $\sum a_{nb} (u'_{nb} - u'_e) = 0,$<br>$d_e = A_e / (a_e - \sum a_{nb})$<br>减轻第二个假定影响 |
| SIMPLEX | $p^*$ 独立地假定, 通过修正量改进, 但压力的修正量不亚松弛   | $\Delta p'_e = \Delta p'_{nb}$ 求解 $d_e$<br>减轻第二个假定影响                                  |



# 密网格下对四个算例比较结果

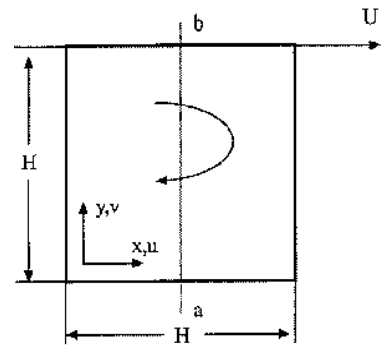

(1) lid-driven cavity flow

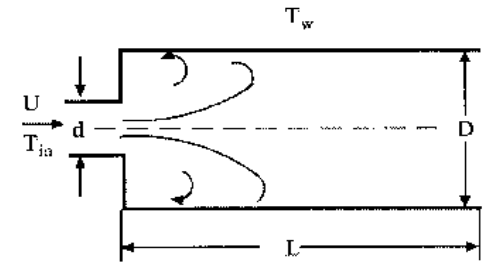

(2) flow in a tube with sudden expansion

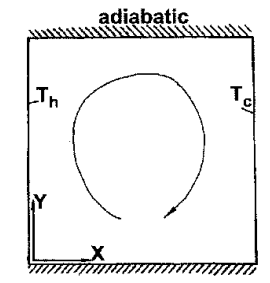

(3) natural convection in a square cavity

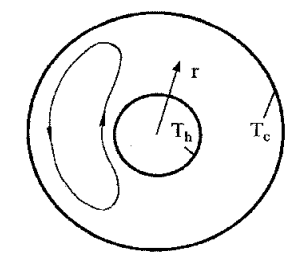

(4) natural convection in a horizontal annular

1. CPU时间:  $SIMPLER/SIMPLEX \geq SIMPLE/SIMPLEC$
2. 健壮性:  $SIMPLE < SIMPLER \leq SIMPLEC/SIMPLEX$
3.  $d$  值:  $SIMPLEC/SIMPLEX$  大于  $SIMPLE/SIMPLER$

**密网格下四种算法中SIMPLEC综合性能最优。**

Zeng M, Tao W Q. A comparison study of the convergence characteristics and robustness for four variants of SIMPLE family at fine grids. *Engineering Computations*, 2003, 20(3/4):320-341

**About  $d$**       $u' = d(\Delta p')$       $d \uparrow$       $\Delta p' \downarrow$

Natural convection in a square cavity

|              | 42 × 42       |               | 42 × 42      |              | 82 × 82       |               | 82 × 82      |              |
|--------------|---------------|---------------|--------------|--------------|---------------|---------------|--------------|--------------|
|              | SIMPLE        | SIMPLER       | SIMPLEC      | SIMPLEX      | SIMPLE        | SIMPLER       | SIMPLEC      | SIMPLEX      |
| $d_u(10,6)$  | <u>0.5927</u> | <u>0.5927</u> | <u>2.964</u> | <u>2.928</u> | <u>0.2981</u> | <u>0.2981</u> | <u>1.490</u> | <u>1.474</u> |
| $d_u(20,20)$ | 0.5960        | 0.5960        | 2.980        | 2.979        | 0.2975        | 0.2975        | 1.488        | 1.488        |

Natural convection in a square cavity

|              | 42 × 42      |              |              |              | 82 × 82       |               |              |              |
|--------------|--------------|--------------|--------------|--------------|---------------|---------------|--------------|--------------|
|              | SIMPLE       | SIMPLER      | SIMPLEC      | SIMPLEX      | SIMPLE        | SIMPLER       | SIMPLEC      | SIMPLEX      |
| $d_u(12,7)$  | <u>1.929</u> | <u>1.930</u> | <u>9.643</u> | <u>9.525</u> | <u>0.9999</u> | <u>0.9999</u> | <u>4.999</u> | <u>4.976</u> |
| $d_u(22,22)$ | 1.874        | 1.873        | 9.368        | 9.265        | 0.9612        | 0.9612        | 4.803        | 4.798        |

**所以在 SIMPLEC, SIMPLEX 算法中压力修正值  $p'$  不需要亚松弛!**

### 3.1.6 压力修正算法是一种预估-校正算法

压力修正算法的计算步骤可以分为两大步：

- 1. 预估步(Prediction step): 1-3**，由设定的 $u^0, v^0$ ，到解出 $u^*, v^*$ ；---得到速度点的预估值
- 2. 校正步(Correction step): 4-6**，解出 $p'$ ，得出满足质量守恒的 $u, v$ 。----得到速度的校正值。

对以上的四种算法，预估与校正均各实施一次，就转到下一层次计算，即更新代数方程的系数再求解。

**1986年提出的PISO算法则进行两次校正，在一定程度上改进了算法的收敛性。**

## 3.2 PISO算法与CLEAR算法介绍

### 3.2.1 PISO算法的基本思想

### 3.2.2 PISO算法的实施步骤

### 3.2.3 校正步数目对PISO收敛性的影响

### 3.2.4 CLEAR算法的基本思想

### 3.2.5 CLEAR算法的算例与讨论

## 3.2 PISA算法与CLEAR算法介绍

### 3.2.1 PISO算法的基本思想

一步预估，两步校正；在第一次校正中获得一个修正后压力及相对应的速度，该速度满足质量守恒并**显式**地满足动量守恒；如此连续几次校正可望能更好地同时满足质量与动量守恒的速度场。

### 3.2.2 PISO算法的实施步骤

#### 1. 预估步：完全同SIMPLE

采用PISO算法中的符号，将预估步的算式表示为：

$$\begin{aligned}
 a_e u_e^* &= \sum a_{nb} u_{nb}^* + b + A_e (p_P^{(k)} - p_E^{(k)}) \\
 a_n v_n^* &= \sum a_{nb} v_{nb}^* + b + A_n (p_P^{(k)} - p_N^{(k)})
 \end{aligned}
 \tag{1}$$

这样得出的速度满足**线性**动量守恒方程，但未必满足质量守恒。**所谓线性动量守恒方程是指动量方程中的系数固定为常数，不受速度变化的影响而且邻点速度为上一次的计算值这种计算式。**

## 2. 第一校正步：基本同SIMPLE

设改进后的压力为  $p^* = p^{(k)} + p'$ ，相应的速度为  $u^{**}$ ， $v^{**}$ ，要求  $u^{**}$ ， $v^{**}$  **显式地** 满足线性动量守恒方程：

$$\begin{aligned}
 a_e u_e^{**} &= \sum a_{nb} u_{nb}^* + b + A_e (p_P^* - p_E^*) \\
 a_e v_n^{**} &= \sum a_{nb} v_{nb}^* + b + A_n (p_P^* - p_N^*)
 \end{aligned}
 \tag{2}$$

**系数未变，右端速度未变：显式地满足线性动量守恒方程**

将式 (2) 减式 (1) ，邻点项可自动消去：

$$a_e u_e^{**} = \sum a_{nb} u_{nb}^* + b + A_e (p_P^* - p_E^*)$$

$$a_e u_e^* = \sum a_{nb} u_{nb}^* + b + A_e (p_P^{(k)} - p_E^{(k)})$$

---

$$a_e (u_e^{**} - u_e^*) = A_e [(p_P^* - p_P^{(k)}) - (p_E^* - p_E^{(k)})]$$

$u_e'$ 
 $p_P'$ 
 $p_E'$

$$a_e u_e' = A_e (p_P' - p_E') \quad u_e' = \frac{A_e}{a_e} (p_P' - p_E')$$

$$a_n v_n' = A_n (p_P' - p_N') \quad v_n' = \frac{A_n}{a_n} (p_P' - p_N')$$

将  $(u^* + u')$ ,  $(v^* + v')$  代入质量守恒方程：

$$[(\rho u)_e - (\rho u)_w] \Delta y + [(\rho v)_n - (\rho v)_s] \Delta x = 0 \quad (\text{稳态问题})$$

可得

$$a_P p'_P = a_E p'_E + a_W p'_W + a_N p'_N + a_S p'_S + b$$

$$a_P = a_E + a_W + a_N + a_S$$

$$a_E = d_e A_e \rho_e \quad a_W = d_w A_w \rho_w \quad a_n = d_n A_n \rho_n \quad a_S = d_s A_s \rho_s$$

$$b = [(\rho u^*)_w - (\rho u^*)_e] A_e + [(\rho v^*)_s - (\rho v^*)_n] A_n$$

求解压力修正值方程后，由第一校正步得出：

$$u_e^{**} = u_e^* + d_e (p'_P - p'_E) \quad v_n^{**} = v_n^* + d_n (p'_P - p'_N)$$



这一速度场满足质量守恒，**显式地满足动量守恒：**

$$a_e u_e^{**} = \sum a_{nb} u_{nb}^* + b + A_e (p_P^* - p_E^*) \quad (2)$$

### 3. 第二校正步：PISO特有

设这一步改进后压力为 $p^{**}$ ，速度场为 $u^{***}, v^{***}$ ，同样要求速度场满足质量守恒，**显式地满足线性动量守恒。**

$$a_e u_e^{***} = \sum a_{nb} u_{nb}^{**} + b + A_e (p_P^{**} - p_E^{**}) \quad (3)$$

$$a_e v_n^{***} = \sum a_{nb} v_{nb}^{**} + b + A_n (p_P^{**} - p_N^{**})$$

以 $u$ 为例，将式 (3) 减式 (2)，**邻点项均属已知：**

$$a_e \underline{(u_e^{***} - u_e^{**})} = \sum a_{nb} (u_{nb}^{**} - u_{nb}^*) + A_e [\underline{(p_P^{**} - p_P^*)} - \underline{(p_E^{**} - p_E^*)}]$$

u''
已知项
p\_P''
p\_E''

$$u_e'' = \underline{\sum [a_{nb} (u_{nb}^{**} - u_{nb}^*) + A_e (p_P'' - p_E'')] / a_e}$$

类似地

$$v_n'' = \underline{\sum [a_{nb} (v_{nb}^{**} - v_{nb}^*) + A_n (p_P'' - p_N'')] / a_n}$$

考虑了邻点速度修正对  $u_e, v_n$  的影响

要求速度场  $u^{***}, v^{***}$  满足质量守恒，写成一般形式：

$$C_e u_e^{***} - C_w u_w^{***} + C_n v_n^{***} - C_s v_s^{***} = 0$$

将  $u^{***} = u^{**} + u''$  等代入，可得  $p''$  的方程：

$$a_P p_P'' = \sum a_{nb} p_{nb}'' + b$$

系数计算式同前，但源项  $b$  为：

$$b = T_w - T_e + T_s - T_n$$

其中  $T_e = \frac{c_e}{a_e} [\sum a_{nb} (u_{nb}^{**} - u_{nb}^*)_e]$   $T_n = \frac{c_n}{a_n} [\sum a_{nb} (v_{nb}^{**} - v_{nb}^*)_n]$

获得  $p''$  后第二次改进的速度为：

$$u_e^{***} = u_e^{**} + \frac{1}{a_e} [\sum a_{nb} (u_{nb}^{**} - u_{nb}^*)_e + A_e (p_P'' - p_E'')]$$

$$v_e^{***} = v_e^{**} + \frac{1}{a_n} [\sum a_{nb} (v_{nb}^{**} - v_{nb}^*)_n + A_n (p_P'' - p_N'')]$$

### 3.2.3 校正步数目对PISO算法收敛性的影响

一般两个校正步即可，第三步的影响就不明显。

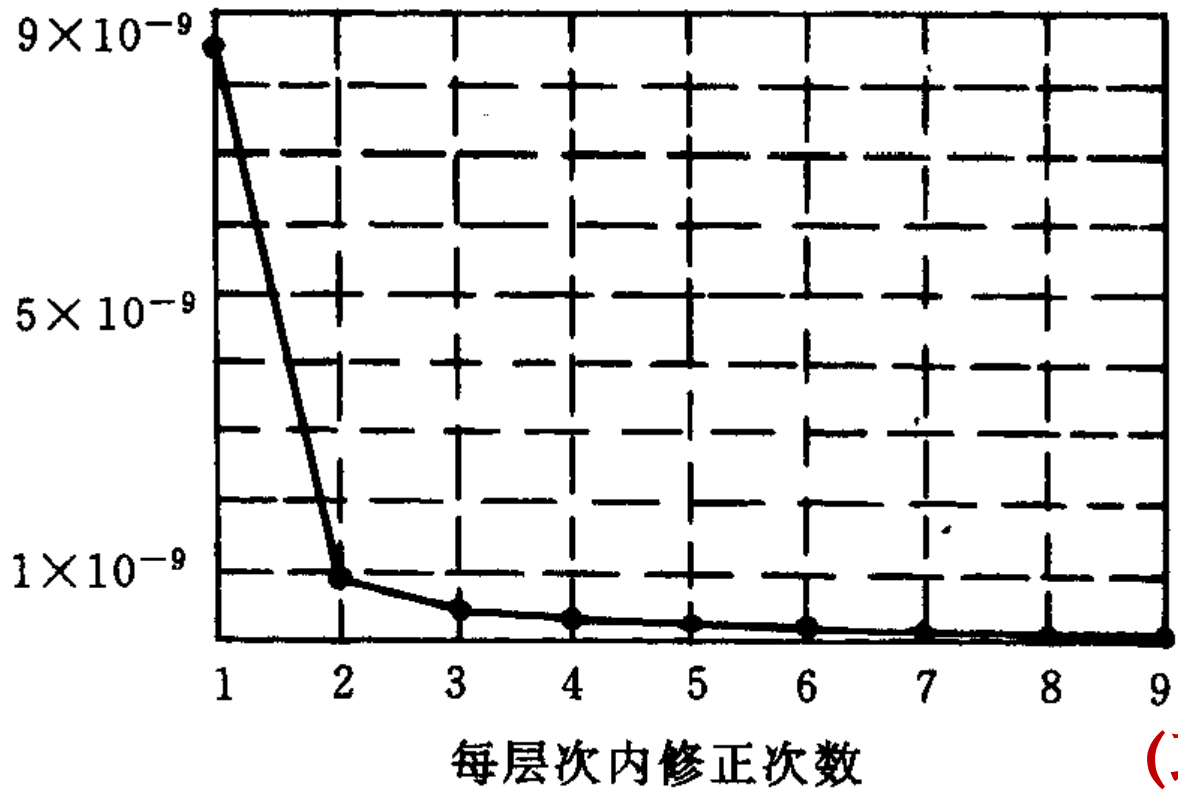

(取自党政的大作业)

PISO算法的多步计算只在校正步中实施。我们后来的实践经验表明同时在预估与校正步中实施多步修正效果更加明显。

## 3.2.4 CLEAR算法的基本思想

### 1. Efforts to overcome the 2<sup>nd</sup> assumption

- 1) SIMPLEC by van Doormaal/Raithby (1984)
- 2) SIMPLEX by van Doormaal/Raithby (1986)
- 3) SIMPLE-with Date modification (1986)
- 4) Explicit correction step method by Yen and Liu(1993)
- 5) SIMPLE-with Sheng et al. modification (1998)
- 6) MSIMPLER by Yu et al. (2001)

All these variants **can only partially overcome the effect of 2nd assumption.** **Why?**

**Analysis:** When the update of velocity is conducted along the line **by adding a small correction to the previous solution, this assumption can never be overcome** for the practical management of the solution of the pressure correction equations.

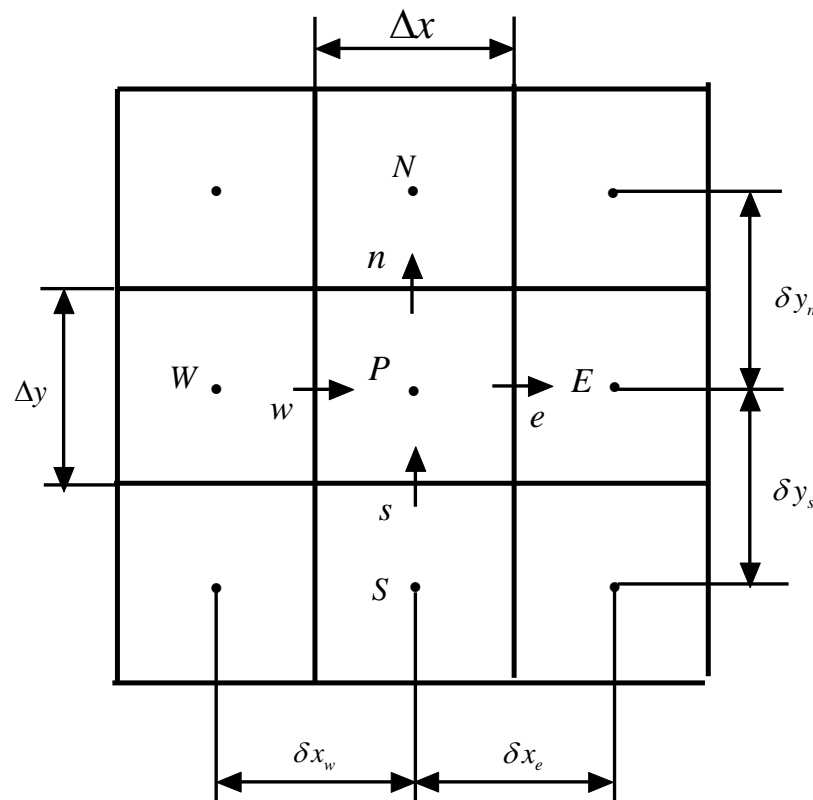

**2-D staggered grid**

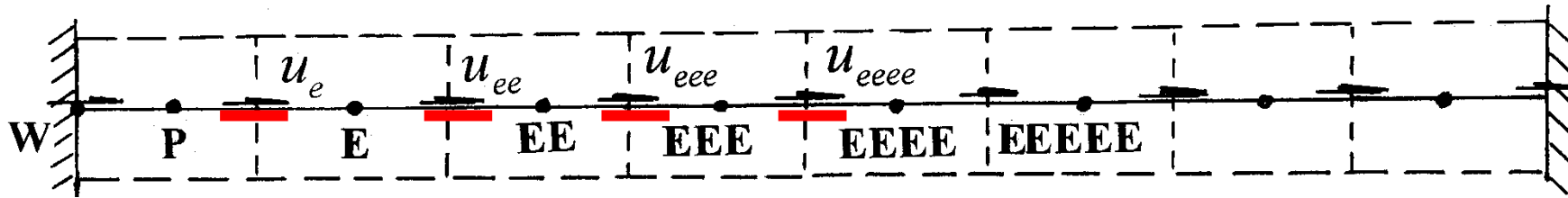

$$a_e u'_e = \sum a_{nb} u'_{nb} + A_e (p'_P - p'_E)$$



$$(a_e u'_e)_{ee} = \left( \sum a_{nb} u'_{nb} + A_e (p'_P - p'_E) \right)_{ee}$$



$$(a_e u'_e)_{eee} = \left( \sum a_{nb} u'_{nb} + A_e (p'_P - p'_E) \right)_{eee}$$



$$(a_e u'_e)_{eeee} = \left( \sum a_{nb} u'_{nb} \right)_{eeee} + (A_e (p'_P - p'_E))_{eeee}$$

**Finally the pressure corrections at all points in the x-direction will be involved.**

In years of 2004 and 2008, our group developed **CLEAR and IDEAL, respectively**. Both versions completely delete the 2<sup>nd</sup> assumption, making the algorithm fully-implicit.

## 2. Basic idea of CLEAR

In the CLEAR algorithm, **the improved pressure is solved directly, rather than by adding a correction term to the intermediate solution; velocity is improved from the updated pressure—a key point of CLEAR (Z G Qu, 屈治国, 2004).**





To implement the above idea, following steps are originally designed:

**Step 1:** Assuming an initial velocity field  $u^0, v^0$  ;  
and calculating the coefficient of the discretized  
momentum equation and pseudo-velocity:

$$v_n^0 = \frac{\sum a_{nb} v_{nb}^0 + b}{a_n} \quad u_e^0 = \frac{\sum a_{nb} u_{nb}^0 + b}{a_e}$$

**Step 2:** Solving the pressure equation and  
obtaining the temporary pressure field  $p^*$  ;

**Step 3:** Solving the momentum equation to get  $u^*$ ,  
 $v^*$  ;

(以上同SIMPLR)

**Step 4: Recalculating the coefficient of momentum equation and the pseudo-velocity  $u^*$ ,  $v^*$  based on the intermediate velocity solution  $u^*$ ,  $v^*$ , and the improved velocity is expressed by**

反映邻点的影响

$$u_e = u_e^* + d_e (\underline{p_P - p_E}) \quad v_n = \tilde{v}_n^* + d_n (\underline{p_P - p_N})$$

相邻两点的压差，不是压力修正值之差！

where  $u_e^*$  and  $\tilde{v}_n^*$  are actually representing the effects of the neighboring grid points, and re-solving the pressure equation for the improved pressure field based on  $u_e^*$ ,  $\tilde{v}_n^*$  which can be derived as follows:

$$a_P p_P = \sum a_{nb} p_{nb} + b$$

$$a_E = (\rho A d)_e \quad a_N = (\rho A d)_n \quad a_P = a_E + a_W + a_N + a_S$$

$$b = (\rho u^* A)_w - (\rho u^* A)_e + (\rho \tilde{v}^* A)_s - (\rho \tilde{v}^* A)_n$$

(the improved pressure is solved directly)

**Step 5:** Improving the velocity to obtain the solution of the present iteration.

$$u_e = u^* + d_e (p_P - p_E) \quad v_n = \tilde{v}^* + d_n (p_P - p_N)$$

(velocity is improved from the updated pressure)

**Step 6:** Returning to step 1 and repeating until convergence is reached.

The major assumption made in the SIMPLE-family is **totally discarded** and a significant acceleration of the convergence speed is obtained (**1972-2004**).

This algorithm is called **CLEAR**-standing for **C**oupled & **L**inked **E**quations **A**lgorithm **R**evised. **The pressure equation are solved twice in CLEAR.**

**Numerically CLEAR can still be regarded as the Prediction—Correction method.** But correction is conducted by directly solving a new pressure rather than by solving the pressure correction equation .

Numerical practices have found that the above computational procedure is sometimes less robust than **SIMPLER**, probably because its too big change of  $p$  between the solutions of two successive iterations. **A second relaxation factor was introduced by Qu to enhance the robustness.**

### 3.2.5 Examples and Discussion

## 1. Numerical application examples of CLEAR

### Example 1: Flow in lid-driven cavity (Re=1000)

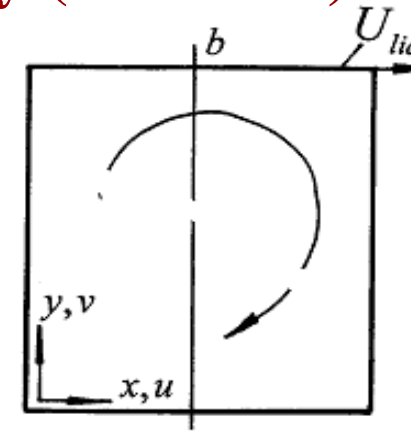
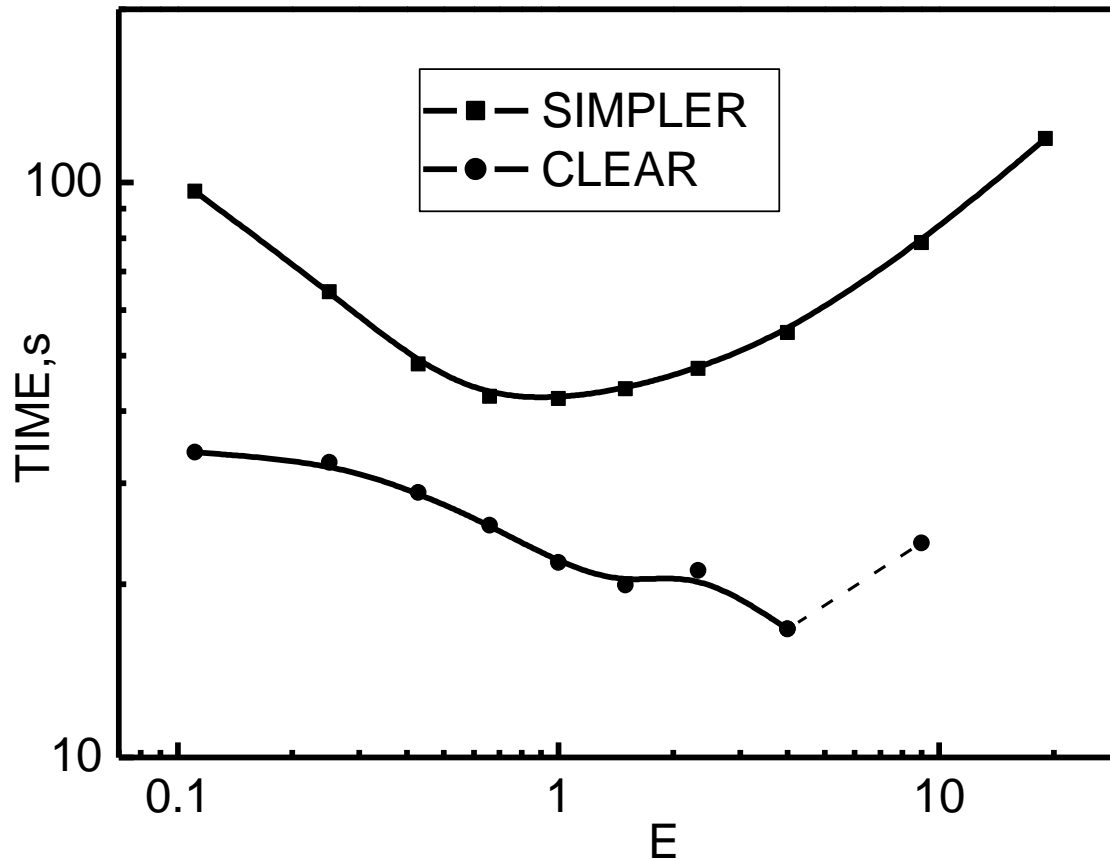

$$E = \frac{\alpha}{1 - \alpha}$$

$$\alpha = 0, E = 0;$$

$$\alpha \rightarrow 1, E \rightarrow \infty$$

称为时步倍率,  
**Time step multiple,**

## Example 2: Heat transfer in a sudden-enlarged tube

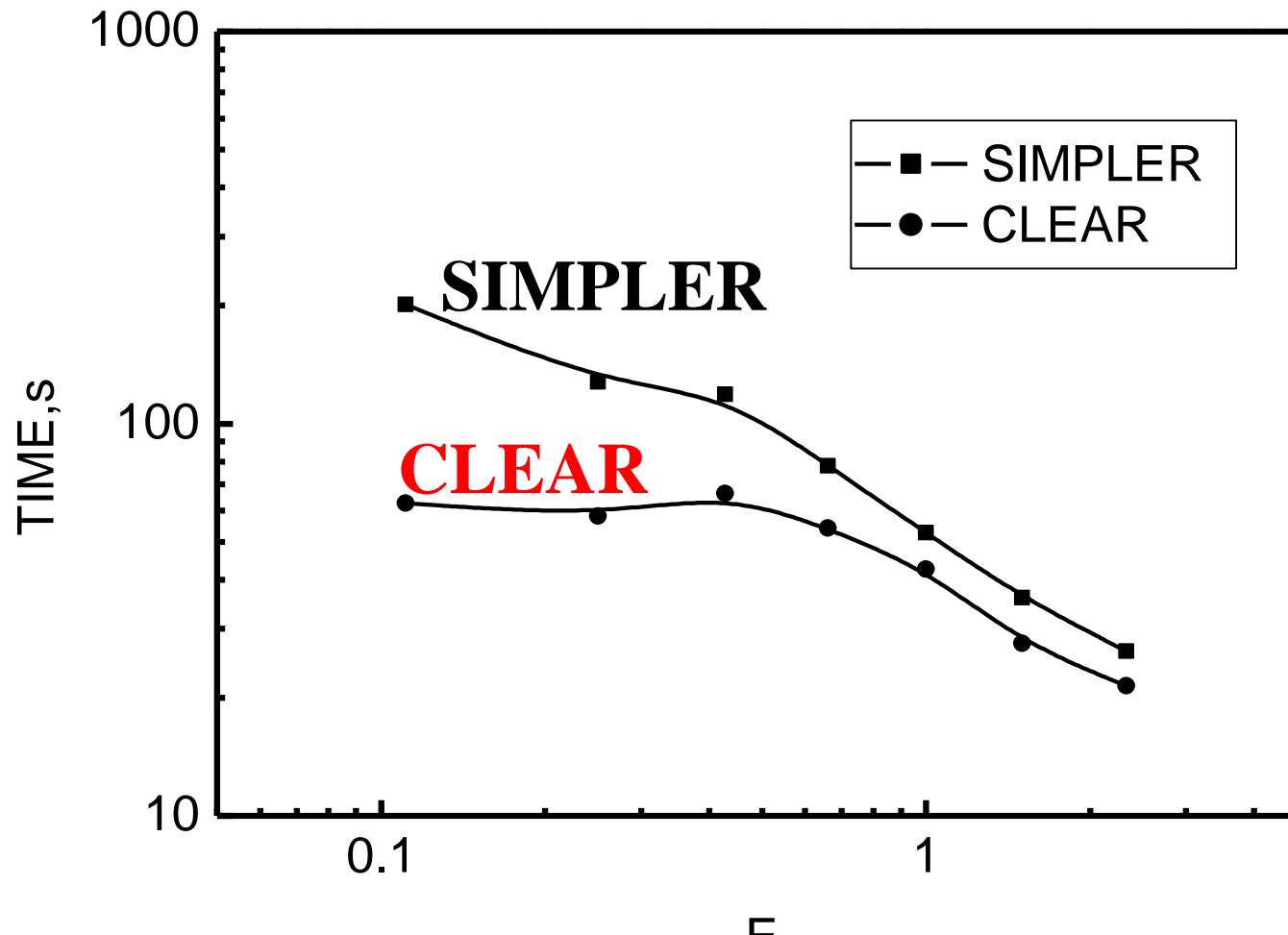
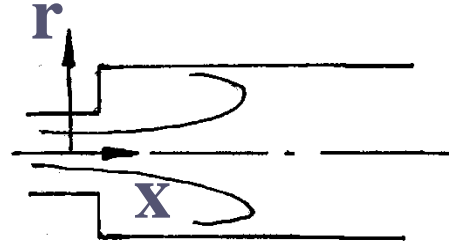

### Example 3 Flow in lid-driven annular cavity

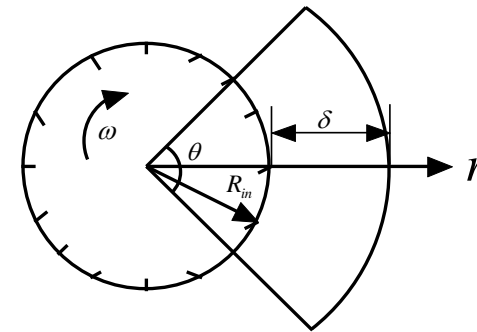
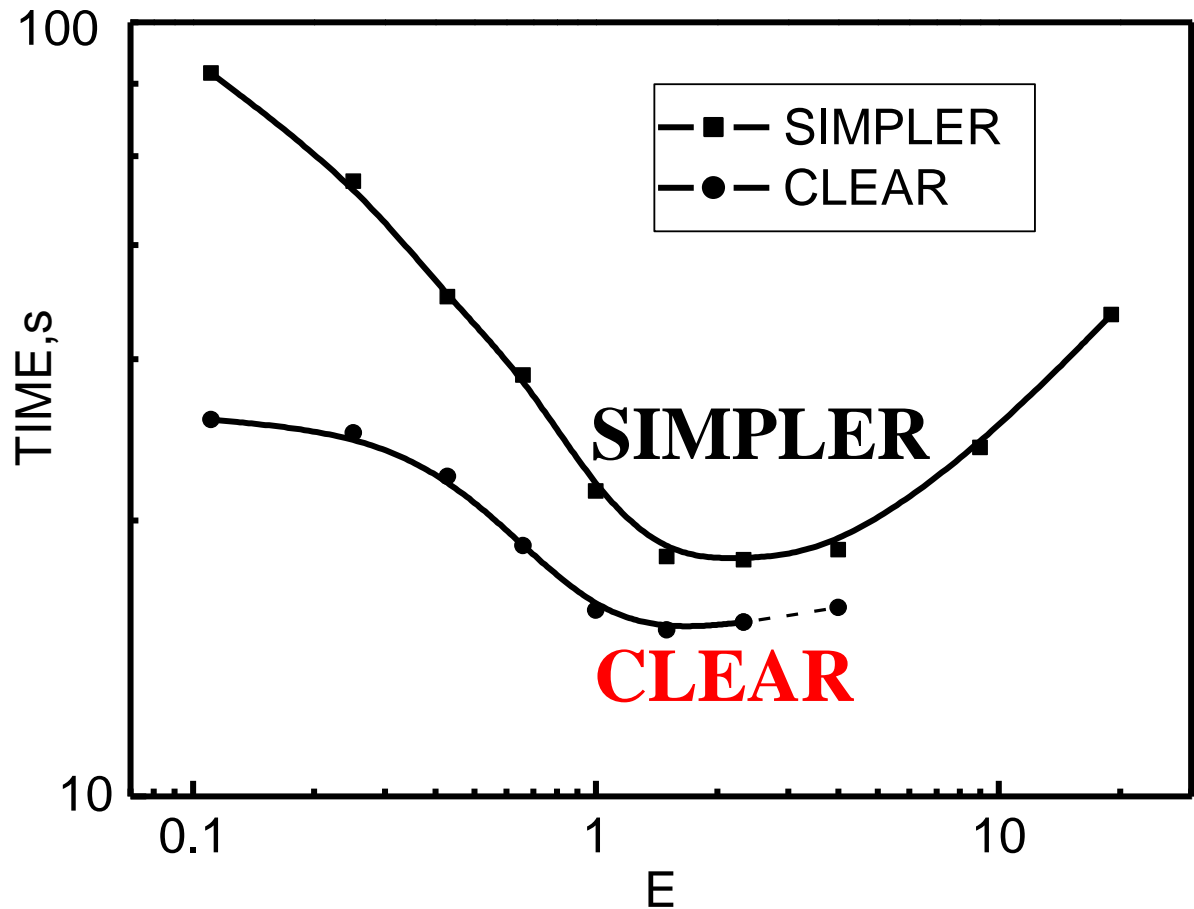

## Example 4: Flow over rectangular backstep

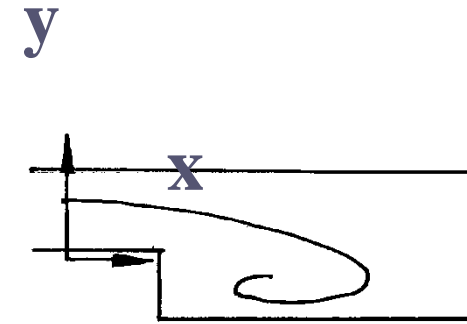
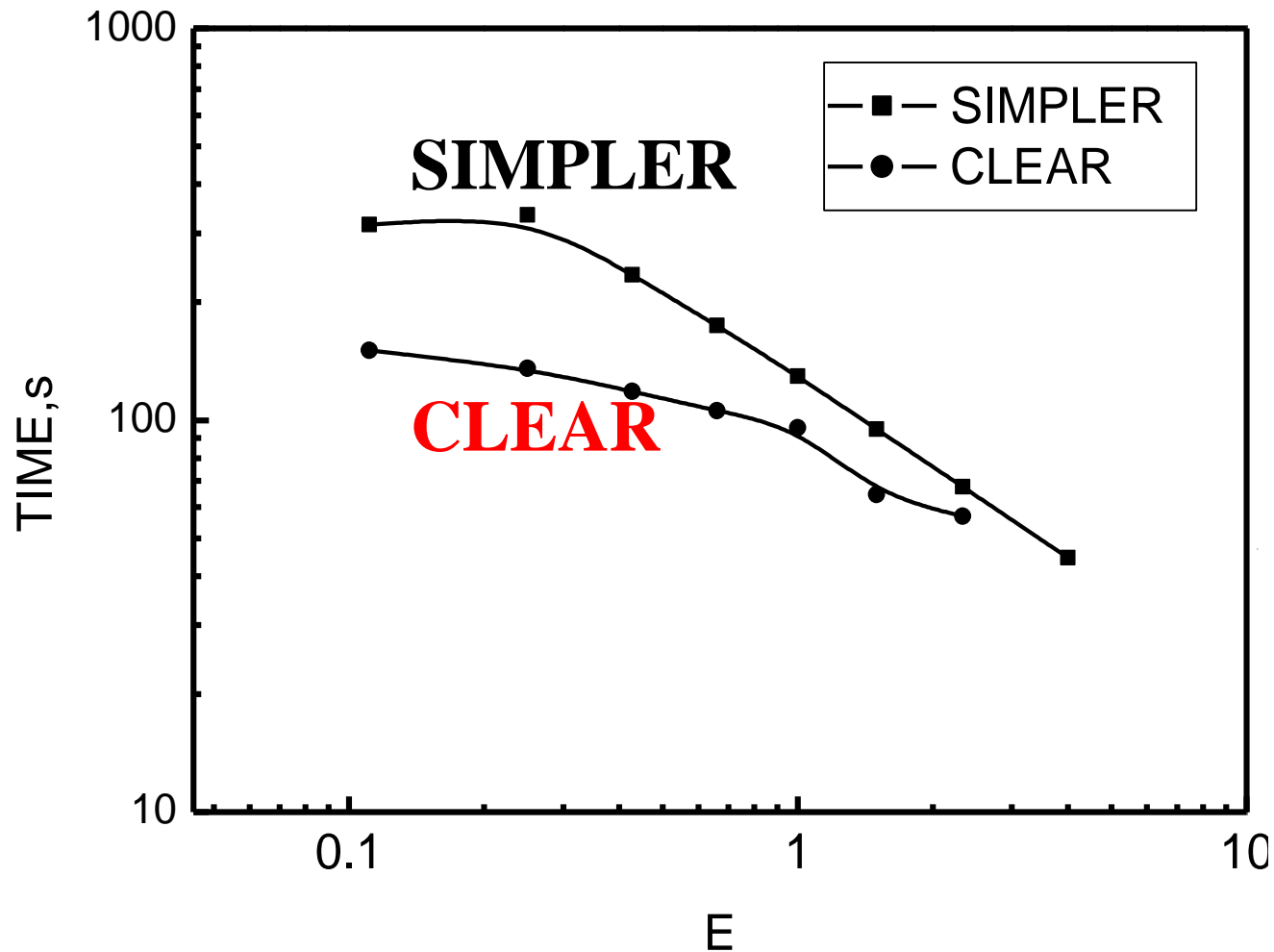



## Example 5: Natural convection in annulus

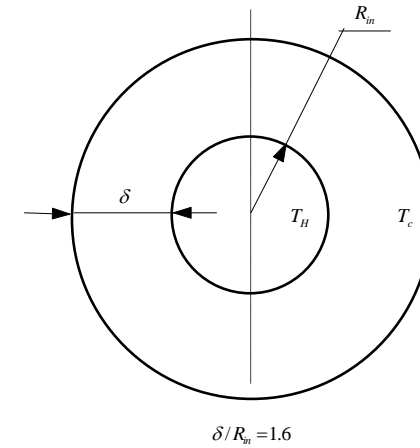
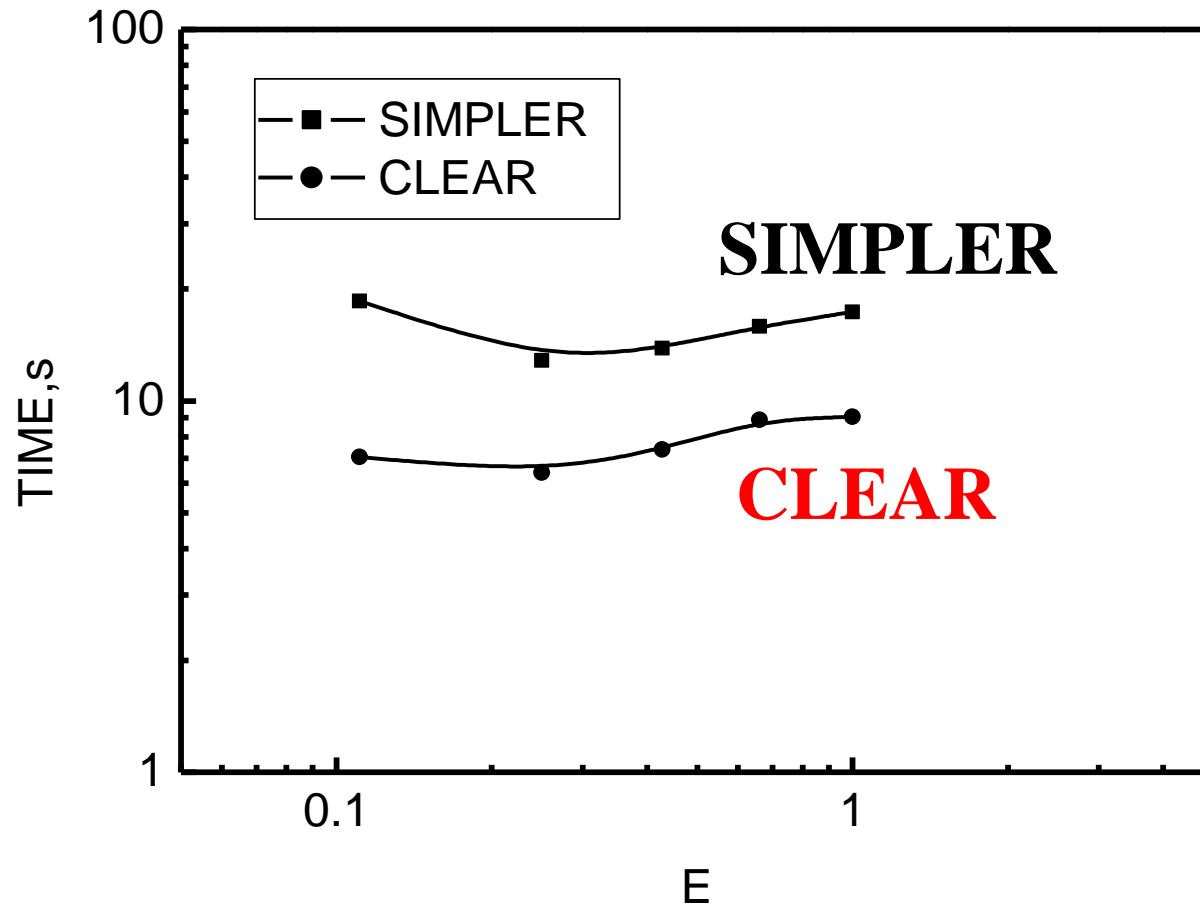

## Example 6 :Natural convection in square cavity

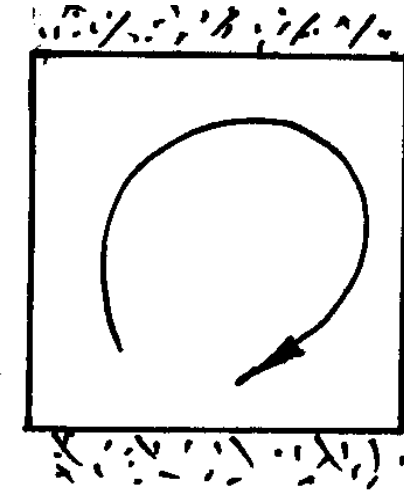
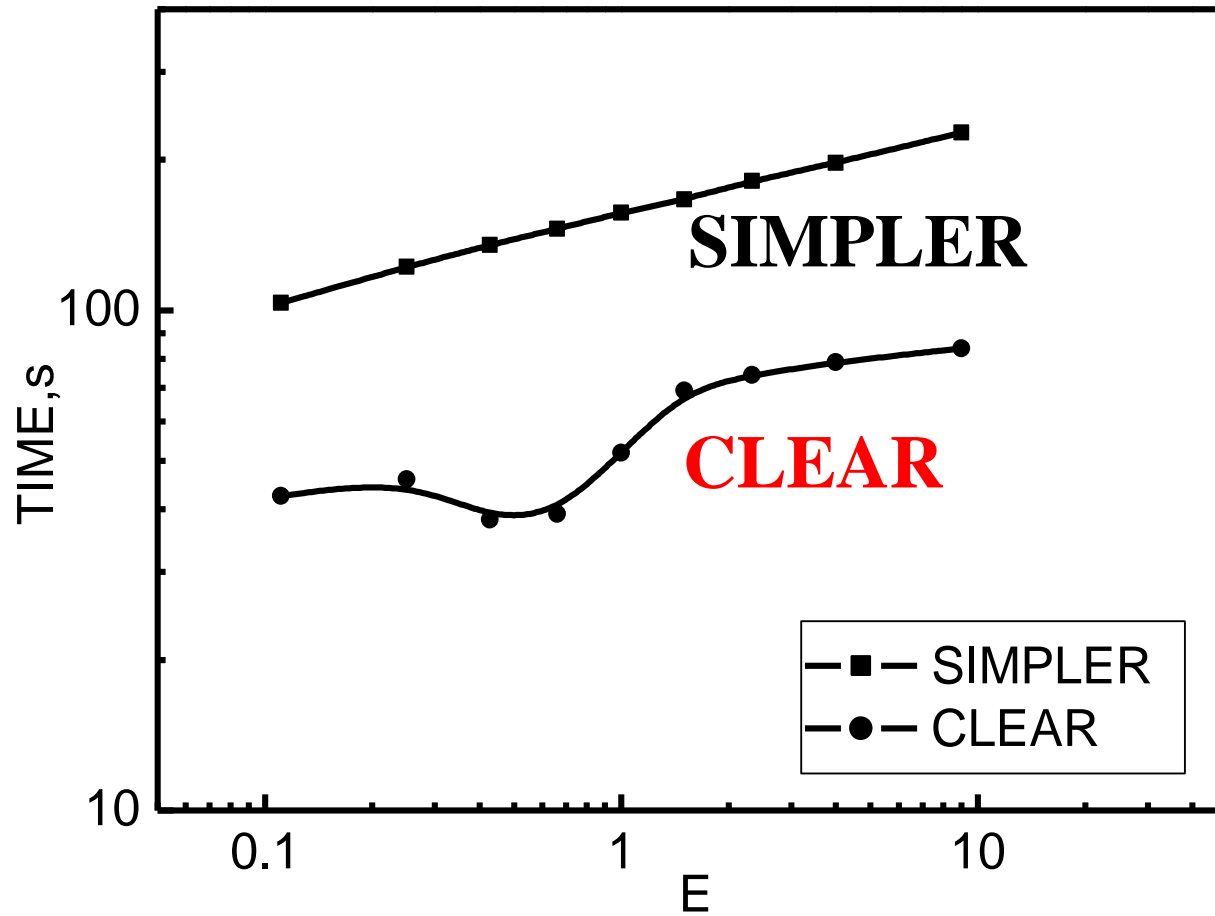

**The six comparison examples in orthogonal coordinates with staggered grids show that ratios of ITER and CPU times of CLEAR over SIMPLER are:**

**ITER=0.15~0.84; CPU=0.19~0.92**

**Saving in CPU time is very appreciable.**

**Extension to non-staggered grid, and non-orthogonal coordinates has been made, and the same results have been obtained.**

## 2. Comparison between SIMPLER and CLEAR in curvilinear non-orthogonal coordinates

### Lid-driven flow in a tilted cavity

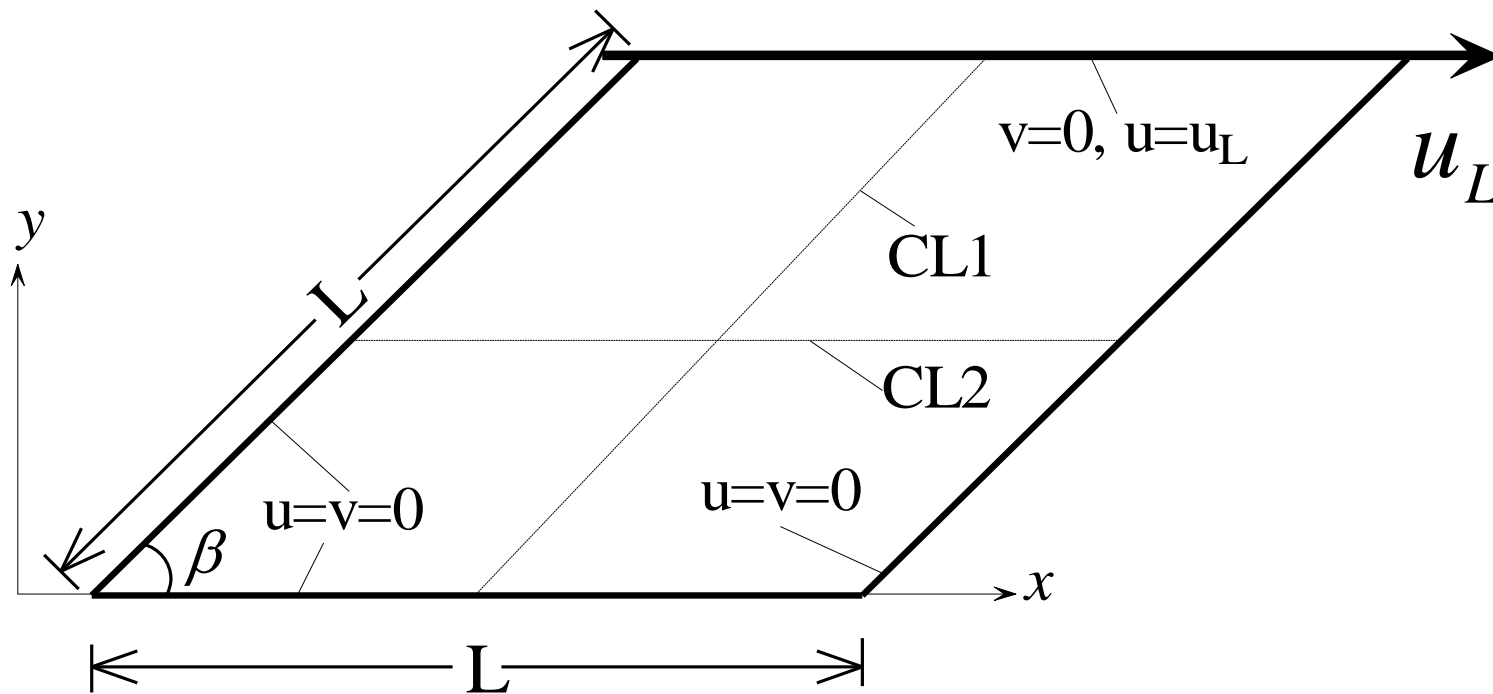

$$\beta = 30^\circ, \text{Re}=1000$$

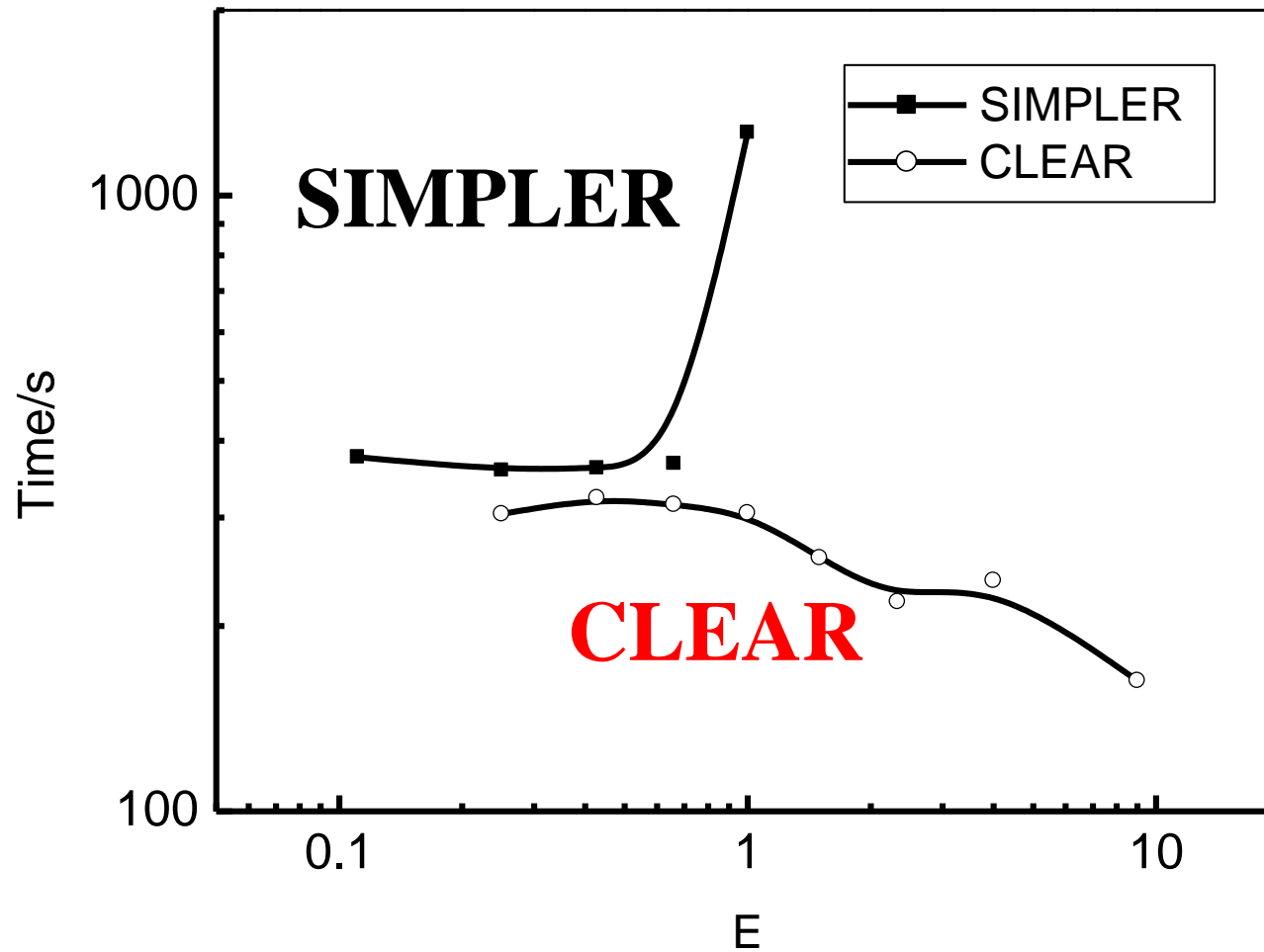

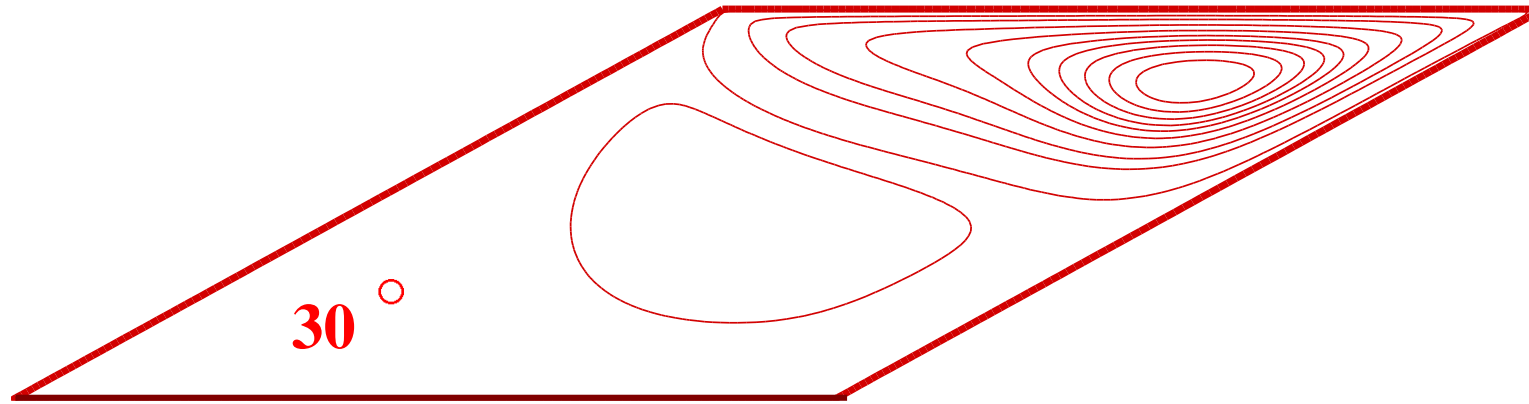

The smallest angle at which SIMPLER can work is **30 degrees;**



The smallest angle at which CLEAR can work is **5 degrees !**

At this angle the grid lines of the two coordinates are **nearly parallel, showing very good robustness!**

Grid lines of  $\beta = 5^\circ$

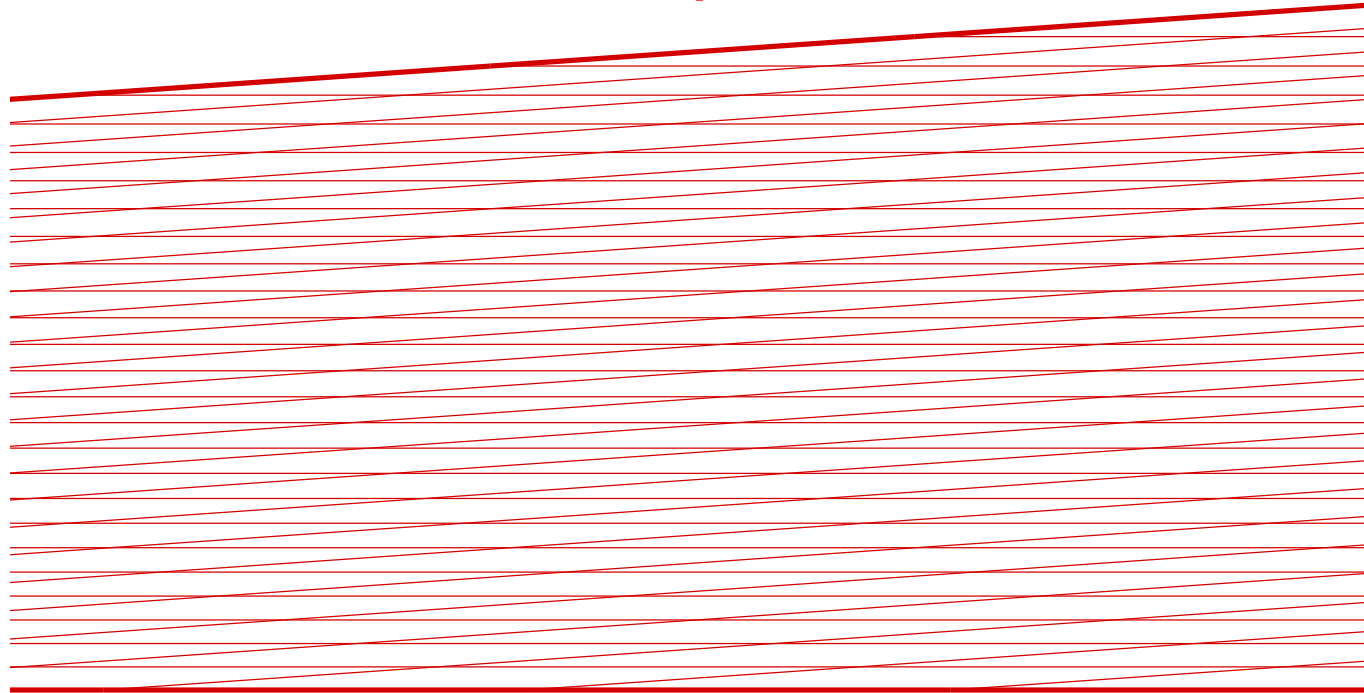

However, generally speaking the robustness of **CLEAR** is inferior to **SIMPLER!**

## 2. Discussion

1. In one iteration two pressure equations are solved in CLEAR, while in SIMPLER one pressure equation and one pressure correction equation are solved. However, in CLEAR the effects of neighboring points are taken into account, leading to a faster convergence rate of CLEAR.

2. In one iteration the coefficients of momentum equation are calculated twice: one for solving the momentum equation, the other for calculation of  $u_e^*, v_n^*$ , not for solving the momentum equation. **Thus the increase in the computational cost is not significant.**

3. The robustness of CLEAR needs to be improved.



## 3.3 IDEAL 算法

**3.3.1 Analysis of the weakness of CLEAR algorithm**

**3.3.2 Basic features of an ideal algorithm**

**3.3.3 Two inner iterations in IDEAL**

**3.3.4 Three kinds of “iteration” in IDEAL**

**3.3.5 Application examples and discussion**

## 3.3 IDEAL算法

### 3.3.1 Analysis of the weakness of CLEAR algorithm

The robustness of **CLEAR** is somewhat worse than **SIMPLER**. Then what is the reason?

This issue has attracted researchers in the international community. For example, **CHENG** and **LEE** in Singapore University presented following analysis and proposed what they call **CLEARER** algorithm.

For the lid-driven cavity flow they recorded the convergence history of **SIMPLER**, **CLEAR** and **CLEARER** and obtained following results.

# Lid-driven cavity flow, $Re=1000$

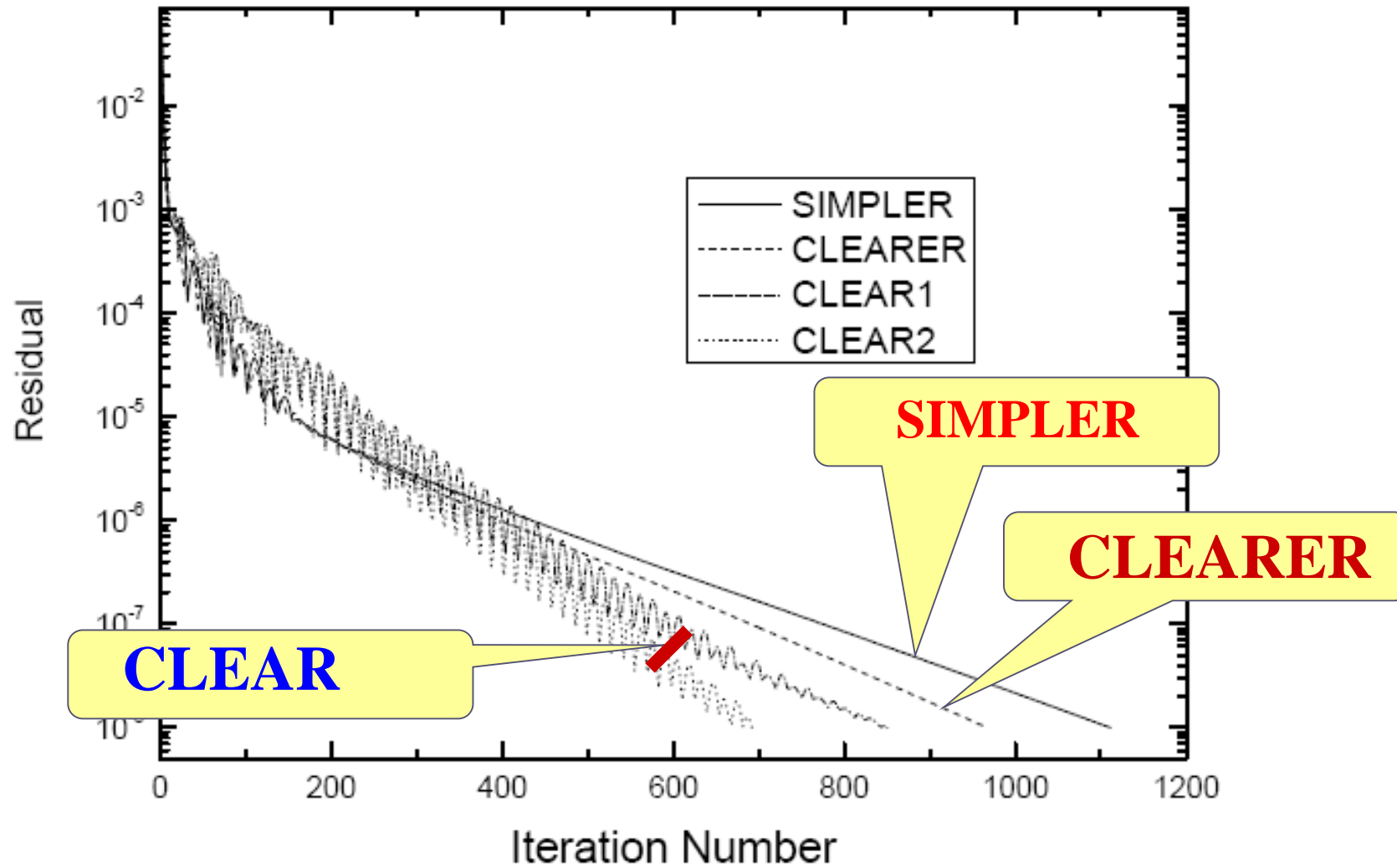

They attributed the oscillation of the numerical solution during iteration to the fact that in SIMPLER the revised velocity is composed of two parts: a major part—intermediate velocity  $u^*, v^*$  and the minor part—corrections  $u', v'$ ,

$$u_e = u_e^* + d_e (p'_P - p'_E)$$

while in CLEAR the corrected velocity is :

$$u_e = u_e^* + d_e (p_P - p_E) \quad v_n = u_n^* + d_n (p_P - p_N)$$

where the two parts of each equation are estimated in the same order. Thus any oscillation in pressure will lead to the bumpiness of velocity.

They proposed a combination of **SIMPLER** and **CLEAR** by computing the revised velocity in the following way:

$$u_e = u_e^* + d_e(p_P^* - p_E^*) + d_e(p_P' - p_E')$$

$$v_n = \tilde{v}_n^* + d_n(p_P^* - p_N^*) + d_n(p_P' - p_N')$$

where  $p'$  is solved by the pressure correction equation.

This revised version is named as **CLEARER**.

Cheng Y P, Lee T S, Low H T, Tao W Q. An efficient and robust numerical scheme for the SIMPLER algorithm on non-orthogonal curvilinear coordinates: CLEARER.

**Numerical Heat Transfer, B, 2007, 51:433-461**

## Our preliminary considerations

Even though CHENG-LEE's revised version possesses some advantage, our consideration would go another direction:

Since the introduction of the velocity correction components makes the algorithm semi-implicit again and it is our believe that semi-implicit poses some limitation to the convergence .

In the PISO algorithm: one more correction step helps to improve convergence; **One more correction step implies a better satisfaction of both momentum and mass conservation!**

From **CLEAR** and **PISO** we can get a hint: a perfect algorithm should possess following features,

## 3.3.2 Basic features of an ideal algorithm

An “**ideal algorithm**” should possess three basic features:

(1) The initial pressure field should be close to the final result of the current iteration as far as possible.

---from **SIMPLER**

(2) The final velocity and pressure of each iteration should satisfy both the momentum and continuity equations as fully as possible. ---from **PISO**

(3) In every step of iteration pressure should be directly solved, and velocity is improved by the updated pressure, not by adding a small correction term.

---from **CLEAR**



孙东亮

To realize above idea following iterative procedure may be adopted:

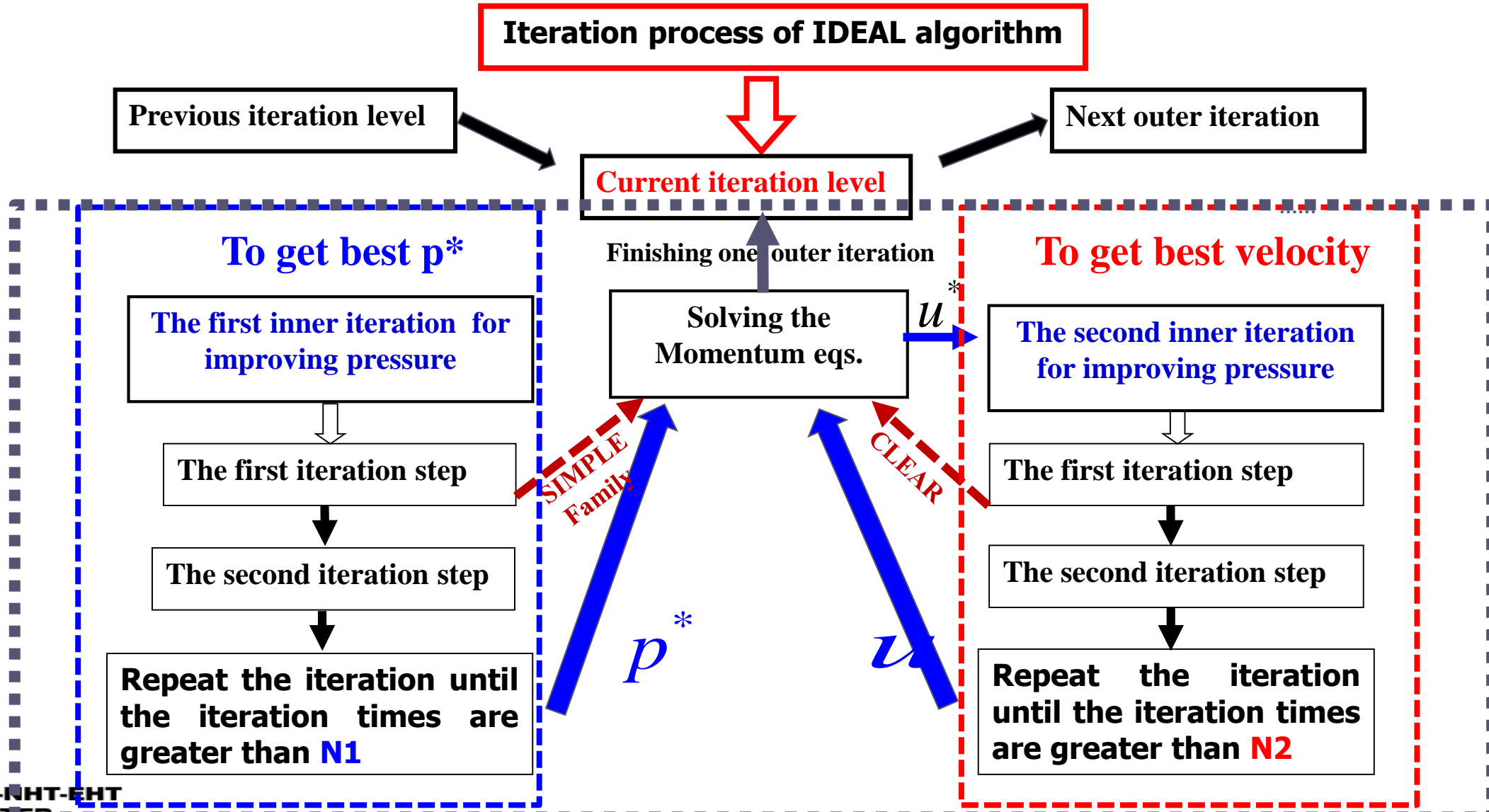



The purpose of the two inner iterations are different:

**The first inner iteration process** for pressure equation is to get a good pressure field for the solution of the momentum equations, simply speaking, **to get the best  $p^*$**  ; ---**Multiple prediction**

**The second inner iteration process for pressure equation is to improve the velocity fields** such that both mass & momentum conservations can be better satisfied. The improvement of velocity field is not proceeded by adding a small correction term, rather, the updated velocity field is obtained via the improved pressure field. ---**Multiple correction**

### 3.3.3 Two inner iterations in IDEAL

#### 1. First inner iteration

|   |   |         |
|---|---|---------|
| $u_e^{Temp} = \tilde{u}_e^0 + d_e (p_P^{Temp} - p_E^{Temp})$  | $\tilde{u}_e^0 = \frac{\sum a_{nb} u_{nb}^0 + b}{a_e / \alpha_u}$ | 假定的速度初场 |
| $v_n^{Temp} = \tilde{v}_n^0 + d_n (p_P^{Temp} - p_N^{Temp})$  | $\tilde{v}_n^0 = \frac{\sum a_{nb} v_{nb}^0 + b}{a_n / \alpha_v}$ |         |
| $a_P p_P^{Temp} = \sum a_{nb} p_{nb}^{Temp} + b$  |   |         |
| $b = (\rho \tilde{u}^0 A)_w - (\rho \tilde{u}^0 A)_e + (\rho \tilde{v}^0 A)_s - (\rho \tilde{v}^0 A)_n$ |   |         |

the first iter. step  
为简便计亚松弛项已经包括在b之内

↓ SIMPLER uses this pressure to solve mom. eq.

|   |   |                           |
|---|---|---------------------------|
| $u_e^{Temp} = \tilde{u}_e^{PTemp} + d_e (p_P^{Temp} - p_E^{Temp})$  | $\tilde{u}_e^{PTemp} = \frac{\sum a_{nb} u_{nb}^{PTemp} + b}{a_e / \alpha_u}$ | 由解出的压力而获得的速度              |
| $v_n^{Temp} = \tilde{v}_n^{PTemp} + d_n (p_P^{Temp} - p_N^{Temp})$  | $\tilde{v}_n^{PTemp} = \frac{\sum a_{nb} v_{nb}^{PTemp} + b}{a_n / \alpha_v}$ |                           |
| $a_P p_P^{Temp} = \sum a_{nb} p_{nb}^{Temp} + b$  |   | the second iteration step |
| $b = (\rho \tilde{u}^{PTemp} A)_w - (\rho \tilde{u}^{PTemp} A)_e + (\rho \tilde{v}^{PTemp} A)_s - (\rho \tilde{v}^{PTemp} A)_n$ |   |                           |

$$u_e^{Temp} = \tilde{u}_e^0 + d_e (p_P^{Temp} - p_E^{Temp})$$

N1..... Obtaining  $p^*$  to solve mom. eq.

**Taking the last solution of pressure of the 1<sup>st</sup> inner iteration as the  $p^*$  for the solution of momentum equation;**

**Solving the momentum equation to get the intermediate velocities  $u^*$ ,  $v^*$ ;**

**Based on the intermediate velocities  $u^*$ ,  $v^*$  conducting the second inner iteration.**

## 2. Second inner iteration

$$u_e^{Temp} = \tilde{u}_e^* + d_e (p_P^{Temp} - p_E^{Temp})$$

$$v_n^{Temp} = \tilde{v}_n^* + d_n (p_P^{Temp} - p_N^{Temp})$$

$$a_P p_P^{Temp} = \sum a_{nb} p_{nb}^{Temp} + b$$

$$b = (\rho \tilde{u}^* A)_w - (\rho \tilde{u}^* A)_e + (\rho \tilde{v}^* A)_s - (\rho \tilde{v}^* A)_n$$

$$\tilde{u}_e^* = \frac{\sum a_{nb} u_{nb}^* + b}{a_e / \alpha_u}$$

$$\tilde{v}_n^* = \frac{\sum a_{nb} v_{nb}^* + b}{a_n / \alpha_v}$$

由动量方程解出，不满足质量守恒

the first iteration step

质量守恒

CLEAR takes the results as the solution of velocity for this iteration and goes to next iteration.

$$u_e^{Temp} = \tilde{u}_e^{PTemp} + d_e (p_P^{Temp} - p_E^{Temp})$$

$$v_n^{Temp} = \tilde{v}_n^{PTemp} + d_n (p_P^{Temp} - p_N^{Temp})$$

$$a_P p_P^{Temp} = \sum a_{nb} p_{nb}^{Temp} + b$$

$$b = (\rho \tilde{u}^{PTemp} A)_w - (\rho \tilde{u}^{PTemp} A)_e + (\rho \tilde{v}^{PTemp} A)_s - (\rho \tilde{v}^{PTemp} A)_n$$

$$\tilde{u}_e^{PTemp} = \frac{\sum a_{nb} u_{nb}^{PTemp} + b}{a_e / \alpha_u}$$

$$\tilde{v}_n^{PTemp} = \frac{\sum a_{nb} v_{nb}^{PTemp} + b}{a_n / \alpha_v}$$

由解出的压力而获得的速度

the second iteration step

$$u_e^{Temp} = \tilde{u}_e^{PTemp} + d_e (p_P^{Temp} - p_E^{Temp})$$

N2..... Obtaining  $u, v$  of this iteration

**Taking the last solution of pressure of the 2nd inner iteration to improve the solution of velocity such that both the mass conservation and momentum equations are expected to be satisfied quite well:**

$$u_e = \tilde{u}_e^{PTemp} + d_e (p_P - p_E)$$

$$v_n = \tilde{v}_n^{PTemp} + d_n (p_P - p_N)$$

### 3.3.4 Three kinds of "iteration" in IDEAL

- 1. The 1<sup>st</sup> kind: Outer iteration (for nonlinearity)** controlled by ITER (iteration number), to up-date the coefficient of momentum equations;
- 2. The 2<sup>nd</sup> kind: Two Inner iteration (for pressure & velocity) controlled by N1,N2**, to find a good initial pressure and to obtain a velocity field which can fairly well satisfy both mass and momentum conservations;
- 3. The 3rd kind: Inner iteration (for solving algebraic equations) controlled by NTIMES in our teaching codes**, to solve the algebraic equation by ADI with block correction technique.

## 3.3.5 Application Examples and discussion

### 1. Conditions for meaningful comparison

Comparison conditions

- (1) The same discretization scheme;
- (2) The same solution of the algebraic equations;
- (3) The same under-relaxation factor;
- (4) The same grid system;
- (5) The same convergence criterion:

$$RS_{\text{Mass}} = \frac{\text{MAX}[|(\rho u^* A)_w - (\rho u^* A)_e + (\rho v^* A)_s - (\rho v^* A)_n|]}{q_m}$$

$$RS_{\text{VMom}} = \frac{\text{MAX}\{|a_n v_n^0 - [\sum_{nb} a_{nb} v_{nb}^0 + b + A_n (p_P - p_N)]|\}}{\rho u_m^2}$$

$$RS_{\text{UMom}} = \frac{\text{MAX}\{|a_e u_e^0 - [\sum_{nb} a_{nb} u_{nb}^0 + b + A_e (p_P - p_E)]|\}}{\rho u_m^2}$$

## 2. Application examples

### Problem 1: 2D Lid-driven cavity flow in a square cavity

For  $Re=100 \sim 10000$ , grid numbers =  $129 \times 129 \sim 260 \times 260$ .

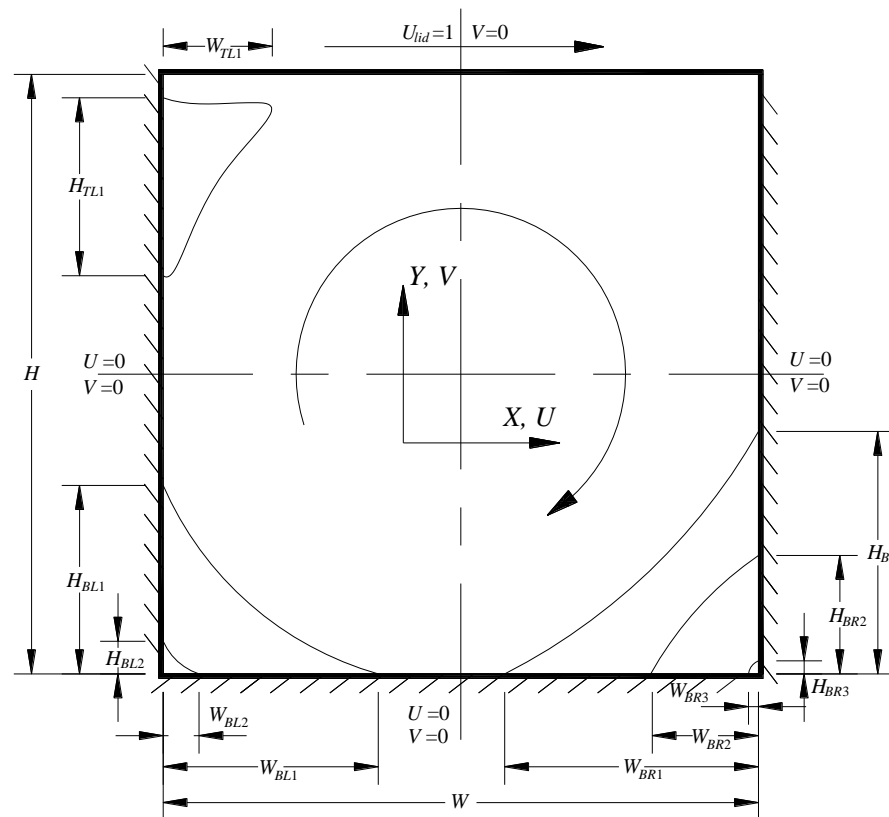



| Grid Numbers   | Comparison terms     |         | <i>Re</i>    |              |              |      |      |      |       |
|----------------|----------------------|---------|--------------|--------------|--------------|------|------|------|-------|
|                |                      |         | 100          | 400          | 1000         | 3200 | 5000 | 7500 | 10000 |
| <u>52 × 52</u> | Time(s)              | IDEAL   | 2.89         | 2.39         | 2.03         | ---  | ---  | ---  | ---   |
|                |                      | SIMPLER | 7.92         | 7.35         | 16.14        | ---  | ---  | ---  | ---   |
|                |                      | Ratio   | <u>0.365</u> | <u>0.325</u> | <u>0.126</u> | ---  | ---  | ---  | ---   |
|                | Iteration Numbers    | IDEAL   | 234          | 184          | 163          | ---  | ---  | ---  | ---   |
|                |                      | SIMPLER | 1264         | 1152         | 2604         | ---  | ---  | ---  | ---   |
|                |                      | Ratio   | <u>0.185</u> | <u>0.160</u> | <u>0.063</u> | ---  | ---  | ---  | ---   |
|                | N1, N2 used in IDEAL |         | <u>4, 4</u>  | <u>4, 4</u>  | <u>4, 4</u>  | ---  | ---  | ---  | ---   |

| Grid Numbers   | Comparison terms     |         | <i>Re</i>    |              |              |      |      |      |       |
|----------------|----------------------|---------|--------------|--------------|--------------|------|------|------|-------|
|                |                      |         | 100          | 400          | 1000         | 3200 | 5000 | 7500 | 10000 |
| <u>82 × 82</u> | Time(s)              | IDEAL   | 18.95        | 13.57        | 12.64        | ---  | ---  | ---  | ---   |
|                |                      | SIMPLER | 56.7         | 46.95        | 69.7         | ---  | ---  | ---  | ---   |
|                |                      | Ratio   | <u>0.334</u> | <u>0.289</u> | <u>0.181</u> | ---  | ---  | ---  | ---   |
|                | Iteration Numbers    | IDEAL   | 499          | 356          | 334          | ---  | ---  | ---  | ---   |
|                |                      | SIMPLER | 3171         | 2623         | 3911         | ---  | ---  | ---  | ---   |
|                |                      | Ratio   | <u>0.157</u> | <u>0.136</u> | <u>0.085</u> | ---  | ---  | ---  | ---   |
|                | N1, N2 used in IDEAL |         | <u>4, 4</u>  | <u>4, 4</u>  | <u>4, 4</u>  | ---  | ---  | ---  | ---   |

| Grid Numbers             | Comparison terms     |         | <i>Re</i> |      |      |      |      |      |       |
|--------------------------|----------------------|---------|-----------|------|------|------|------|------|-------|
|                          |                      |         | 100       | 400  | 1000 | 3200 | 5000 | 7500 | 10000 |
| <u>130</u><br><u>130</u> | Time(s)              | IDEAL   | C         | C    | C    | C    | C    | ---  | ---   |
|                          |                      | SIMPLER | D         | D    | D    | D    | D    | ---  | ---   |
|                          |                      | Ratio   | 0         | 0    | 0    | 0    | 0    | ---  | ---   |
|                          | Iteration Numbers    | IDEAL   | C         | C    | C    | C    | C    | ---  | ---   |
|                          |                      | SIMPLER | D         | D    | D    | D    | D    | ---  | ---   |
|                          |                      | Ratio   | 0         | 0    | 0    | 0    | 0    | ---  | ---   |
|                          | N1, N2 used in IDEAL |         | 5, 5      | 5, 5 | 5, 5 | 5, 5 | 5, 5 | ---  | ---   |

| Grid Numbers             | Comparison terms     |         | <i>Re</i> |       |       |       |       |        |        |
|--------------------------|----------------------|---------|-----------|-------|-------|-------|-------|--------|--------|
|                          |                      |         | 100       | 400   | 1000  | 3200  | 5000  | 7500   | 10000  |
| <u>260</u><br><u>260</u> | Time(s)              | IDEAL   | C         | C     | C     | C     | C     | C      | C      |
|                          |                      | SIMPLER | D         | D     | D     | D     | D     | D      | D      |
|                          |                      | Ratio   | 0         | 0     | 0     | 0     | 0     | 0      | 0      |
|                          | Iteration Numbers    | IDEAL   | C         | C     | C     | C     | C     | C      | C      |
|                          |                      | SIMPLER | D         | D     | D     | D     | D     | D      | D      |
|                          |                      | Ratio   | 0         | 0     | 0     | 0     | 0     | 0      | 0      |
|                          | N1, N2 used in IDEAL |         | 10,10     | 10,10 | 10,10 | 10,10 | 10,10 | 10, 10 | 10, 10 |

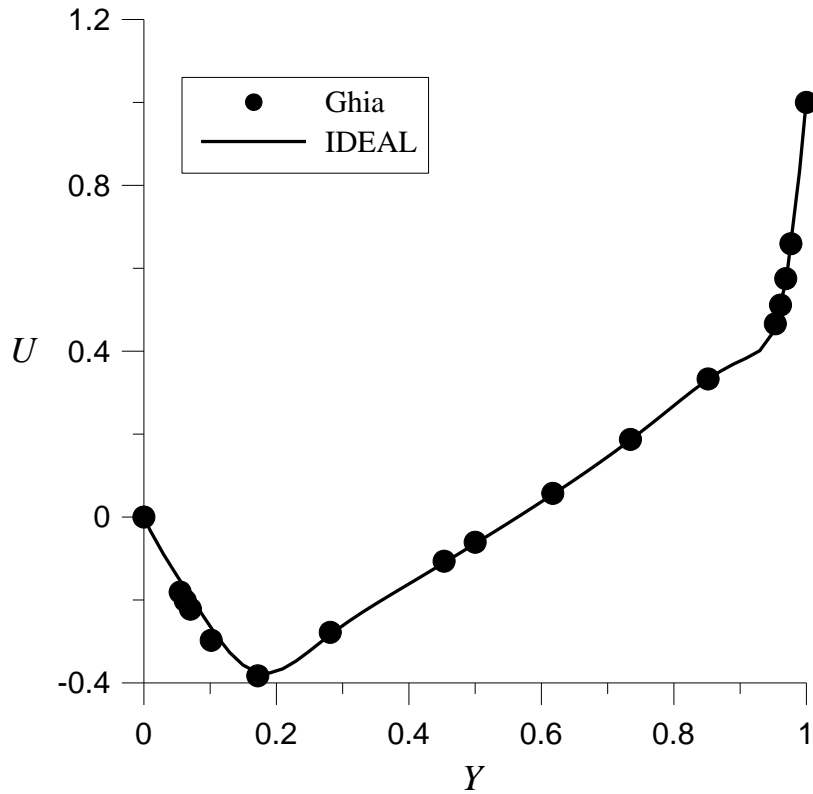

(a)

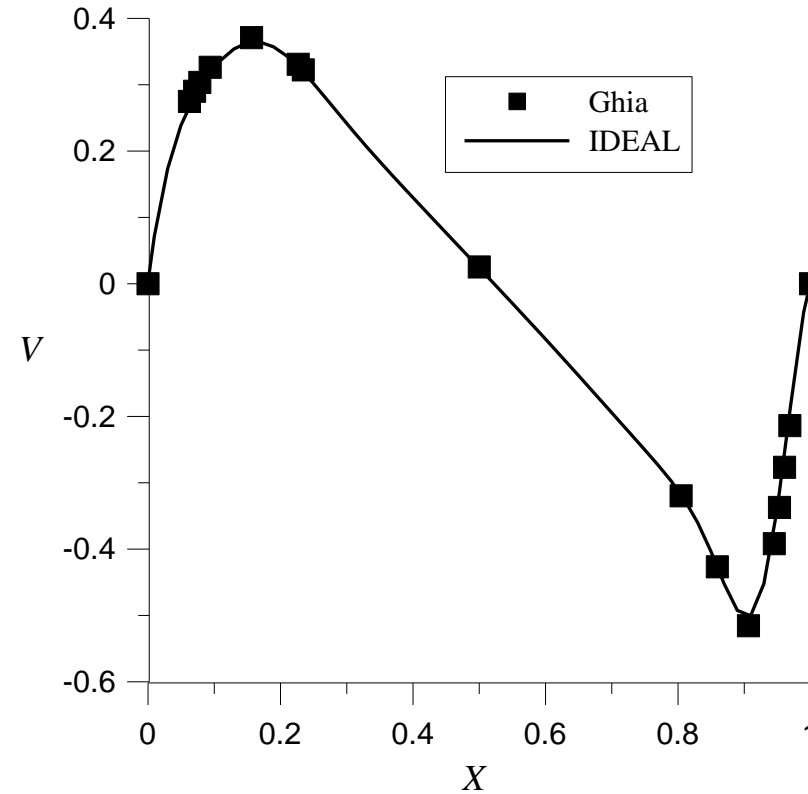

(b)

**Predicted velocity distributions for  $Re=1000$  and grid numbers= $52 \times 52$**

**(a)  $U$  component distribution along  $X=0.5$ ;**

**(b)  $V$  component distribution along  $Y=0.5$ .**

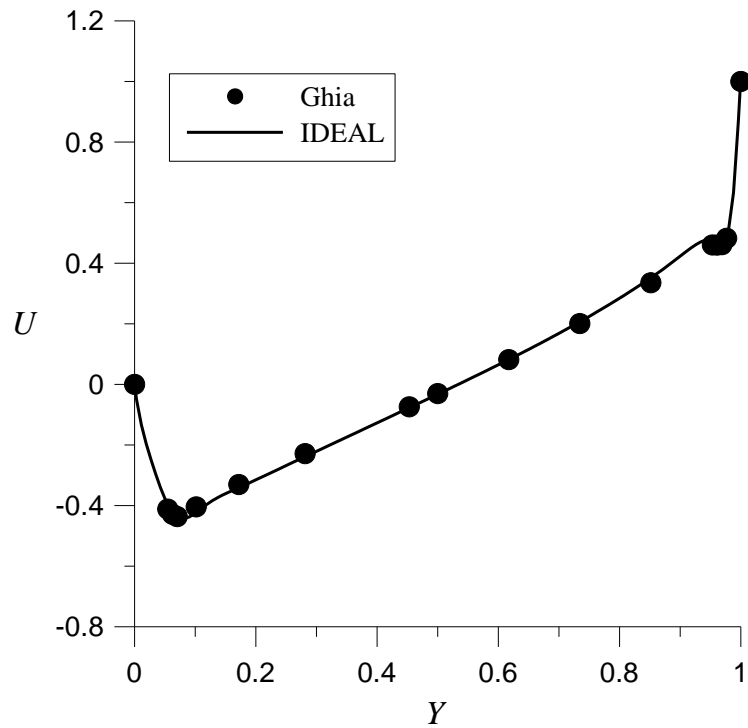

(a)

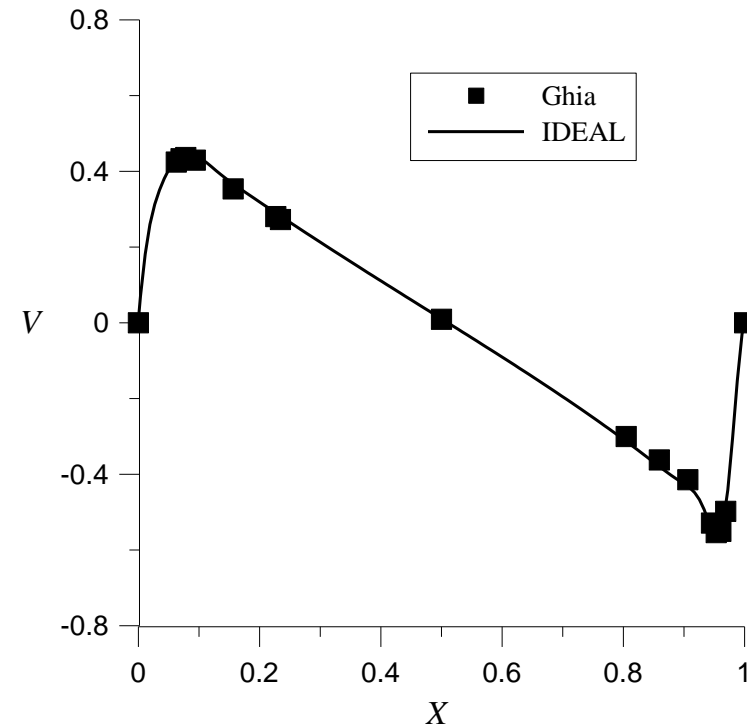

(b)

**Predicted velocity distributions for  $Re=5000$  and grid numbers= $130 \times 130$**

**(a)  $U$  component distribution along  $X=0.5$ ;**

**(b)  $V$  component distribution along  $Y=0.5$ .**

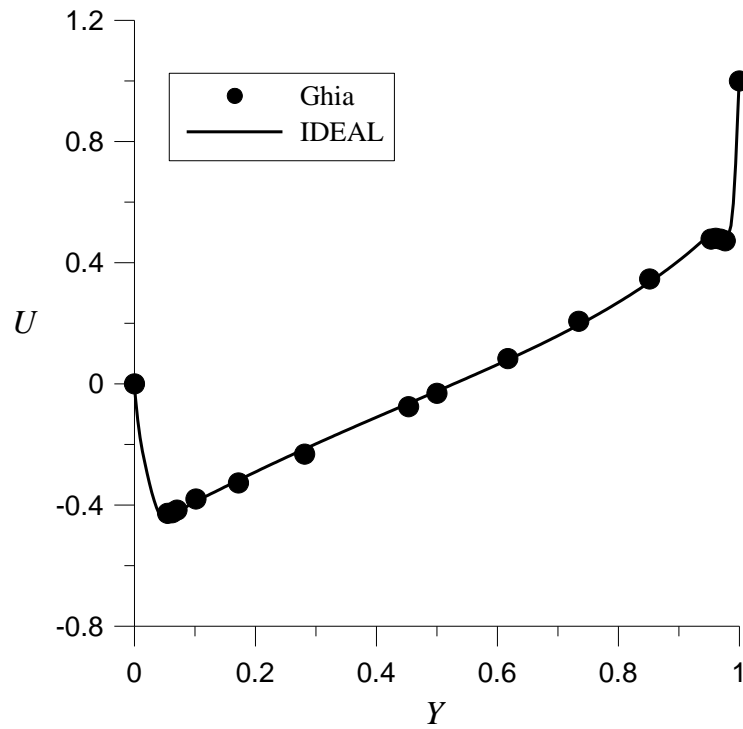

(a)

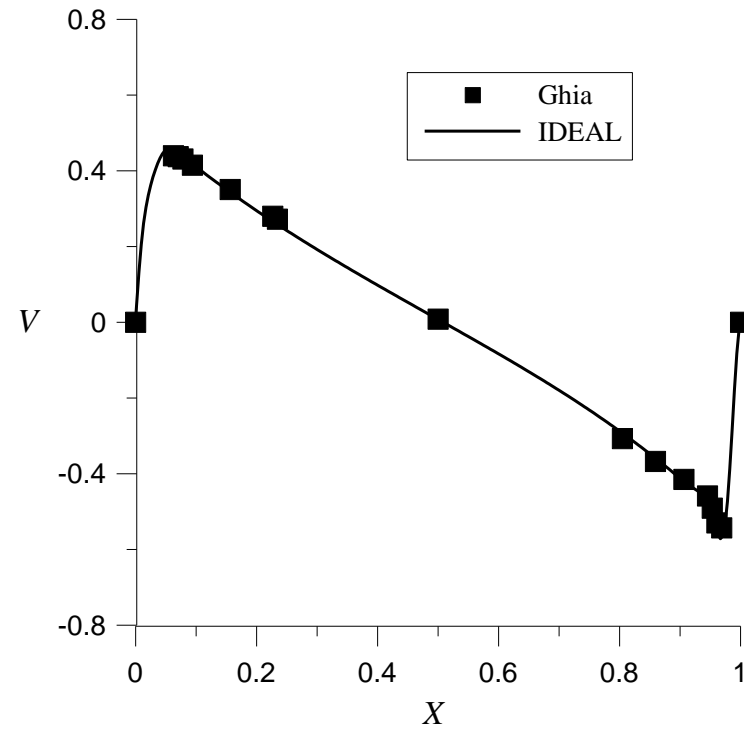

(b)

**Predicted velocity distributions for  $Re=10000$  and  
grid numbers= $260 \times 260$**

**(a)  $U$  component distribution along  $X=0.5$ ;**

**(b)  $V$  component distribution along  $Y=0.5$ .**

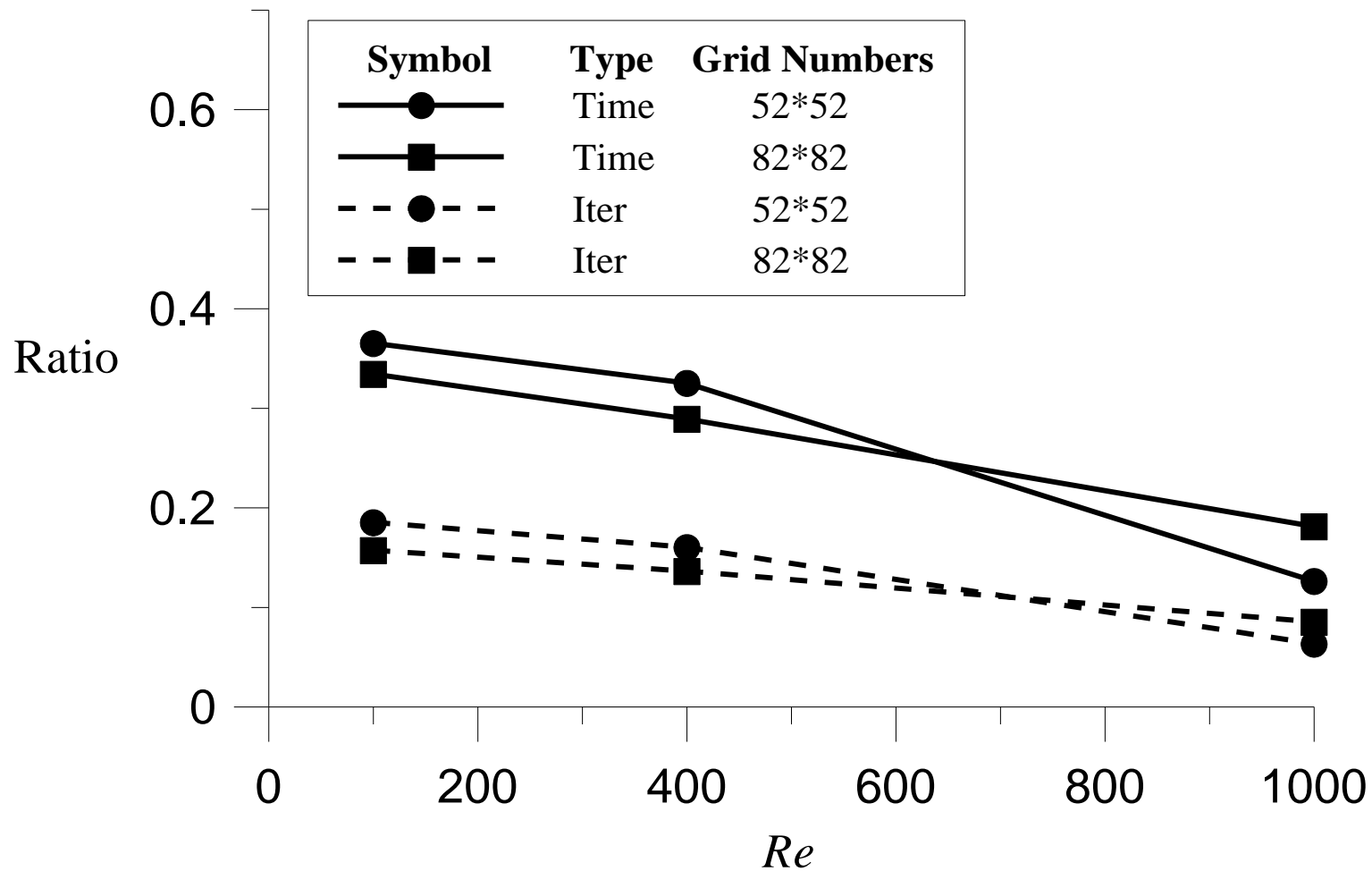

**Ratios of CPU time and iteration numbers**



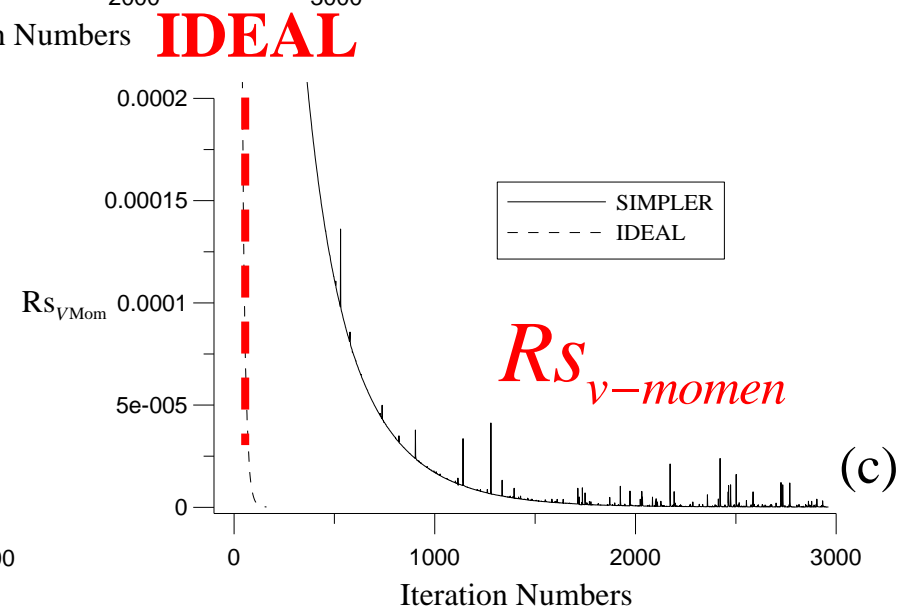
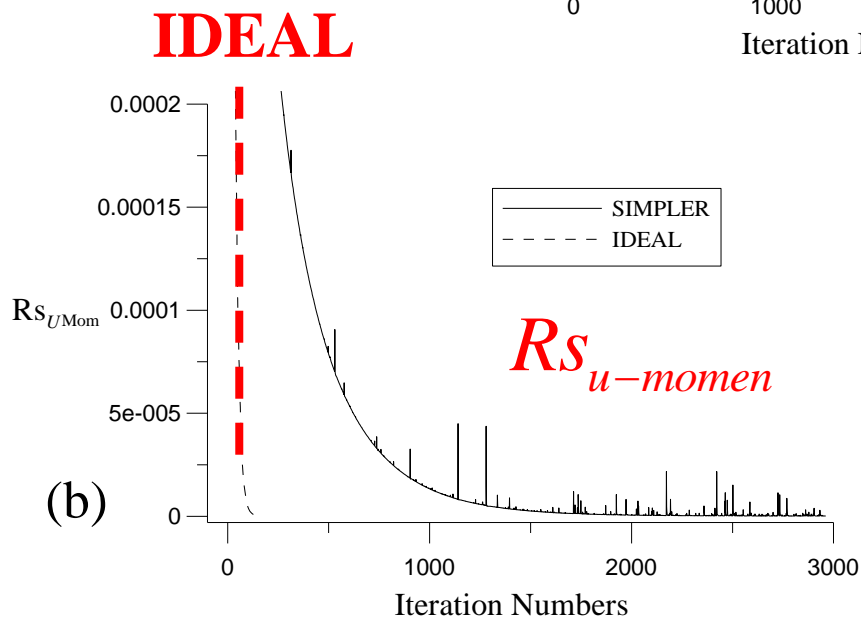
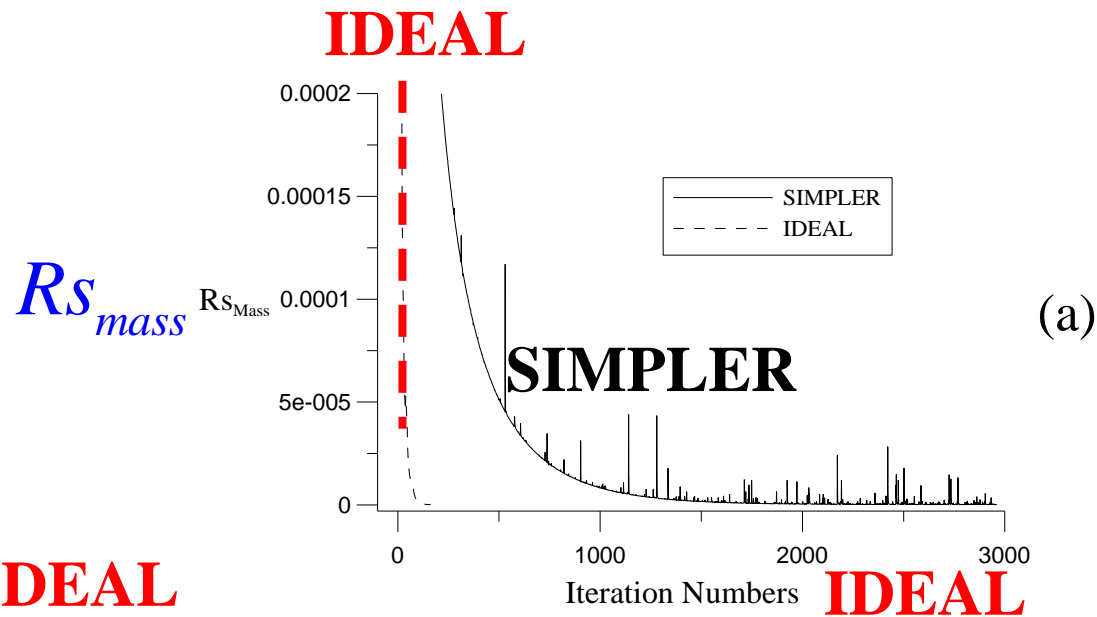

**Convergence history at  $Re=1000$ ,  $52 \times 52$**

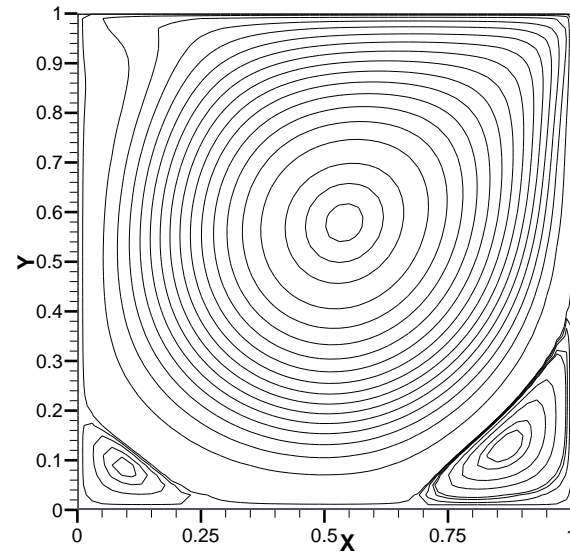

(a)  $Re=1000$ ,  $52 \times 52$ ;

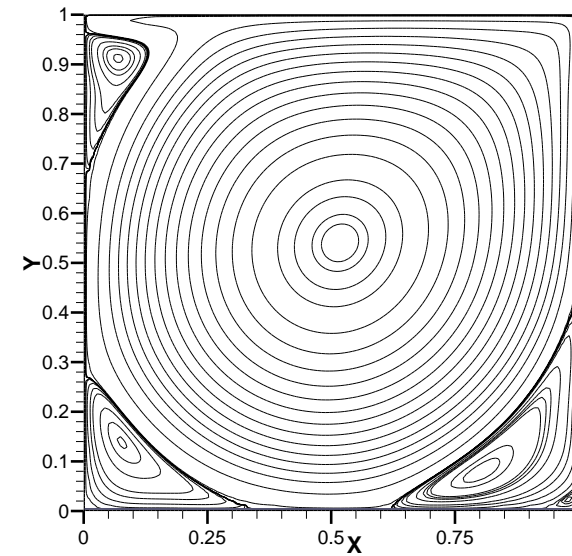

(b)  $Re=5000$ ,  $130 \times 130$ ;

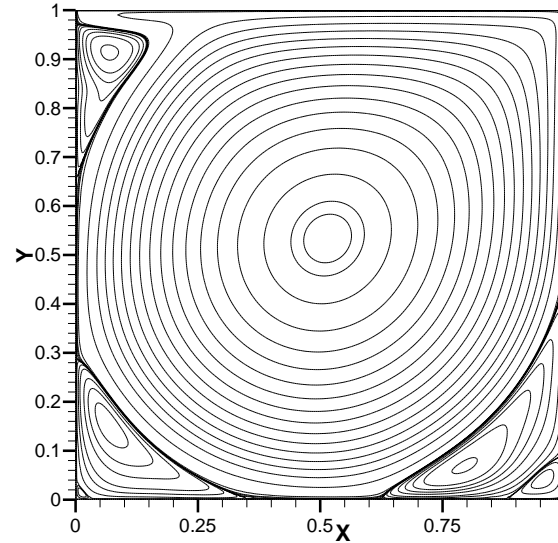

(c)  $Re=7500$ ,  $260 \times 260$ ;

**Predicted flow fields at  $Re=1000$  to  $7500$**

# Problem 2: 2D natural convection in a square cavity

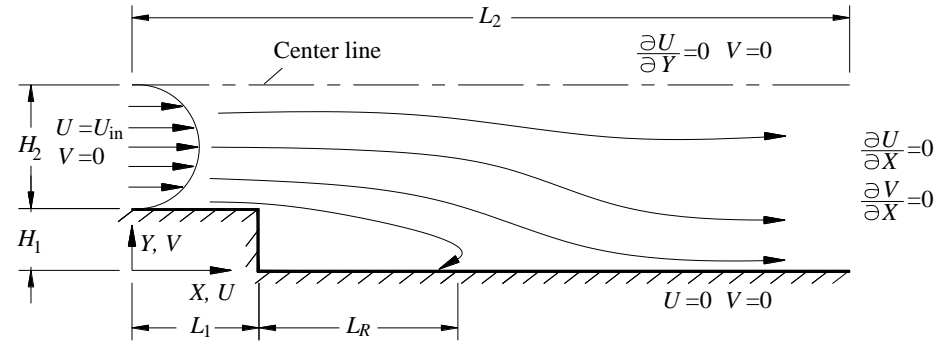
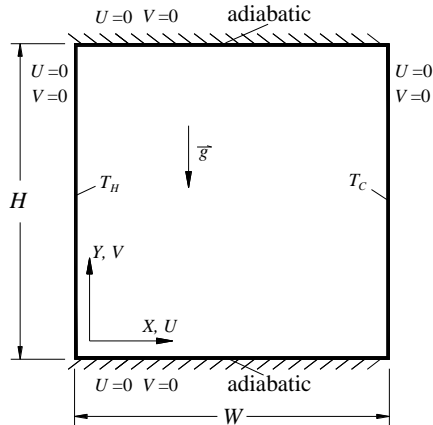

# Problem 3: 2D laminar fluid flow over a rectangular backward-facing Step

# Problem 4: 2D natural convection in a square cavity with an internal isolated vertical plate

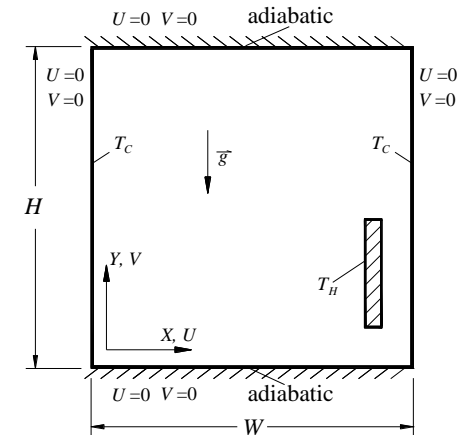

## Problems 5: 3D lid-driven cavity flow

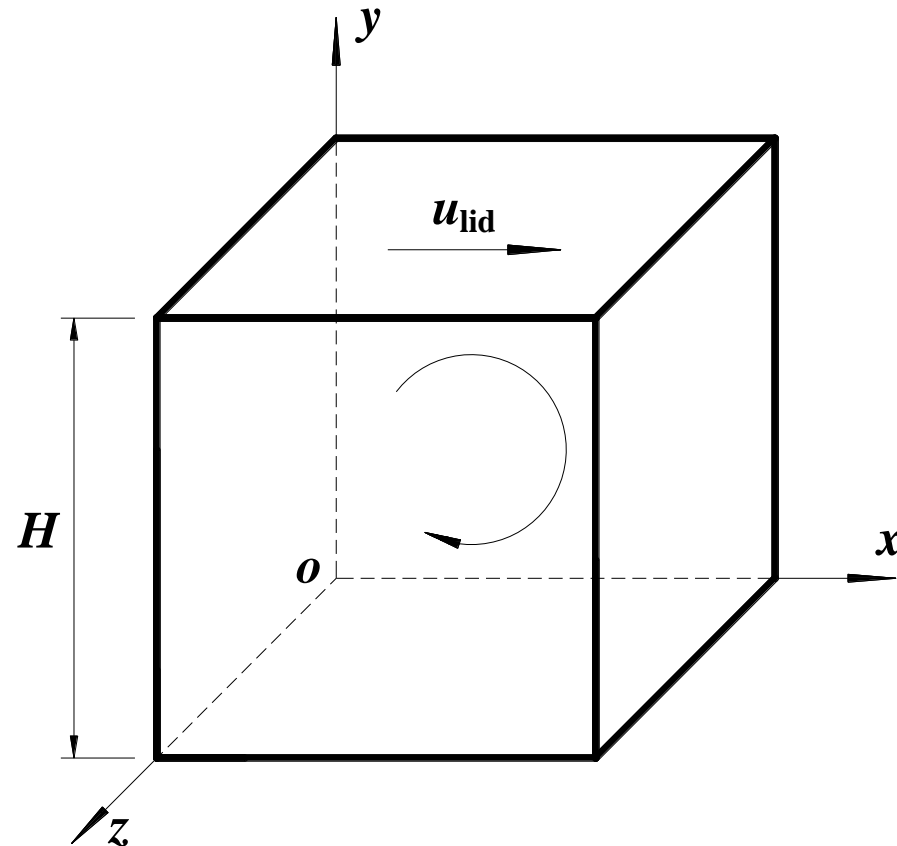

**Flow configuration of lid-driven cavity flow in a cubic cavity**

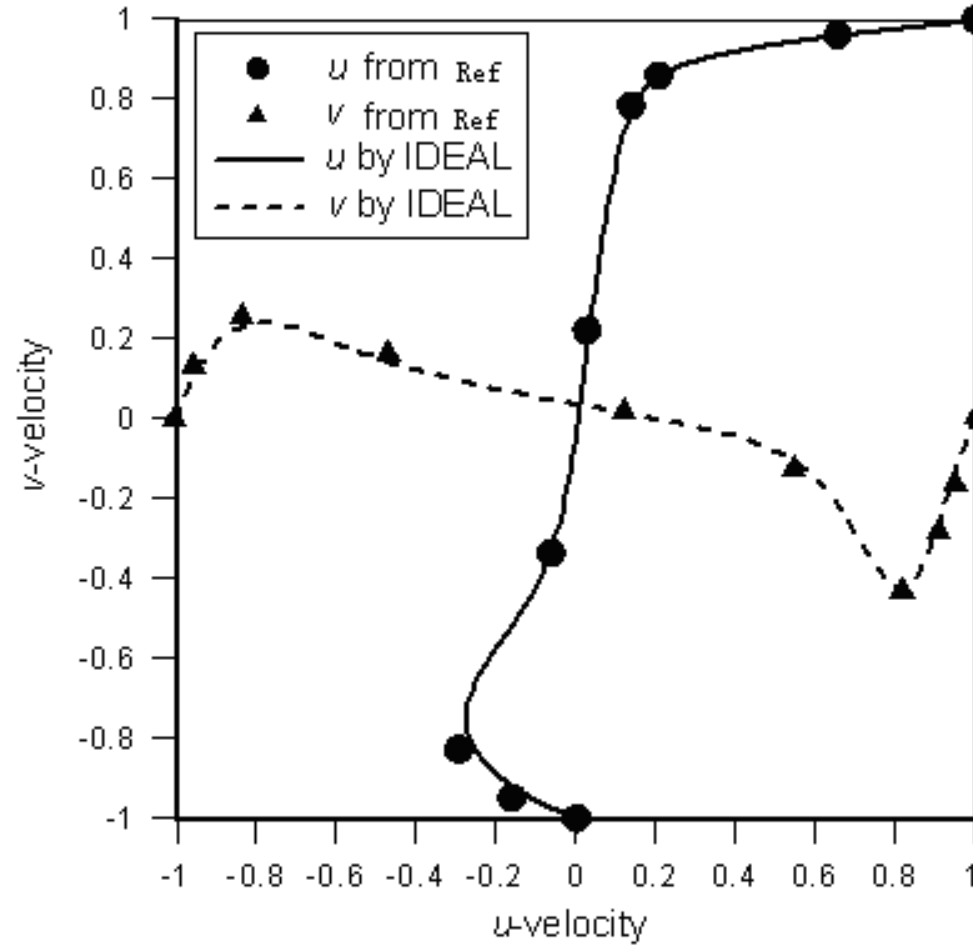

**Comparison of velocity profiles  $u$  and  $v$  along the central axes on plane  $z=0.5H$  for  $Re=1000$**

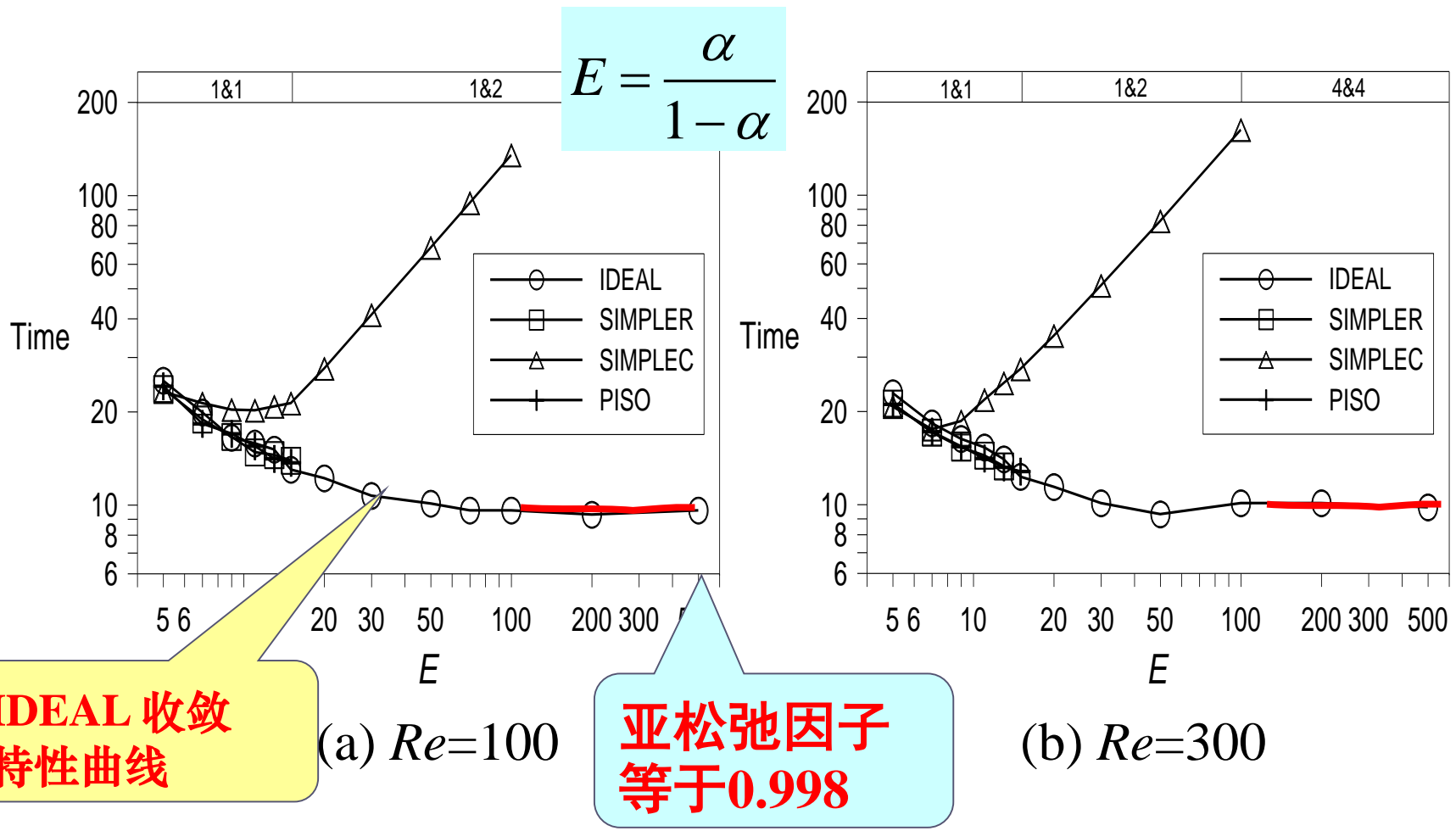

**Comparison of computation time and robustness of IDEAL, SIMPLER, SIMPLEC and PISO algorithms for (a)  $Re=100$  and (b)  $Re=300$  with grid number= $32 \times 32 \times 32$**

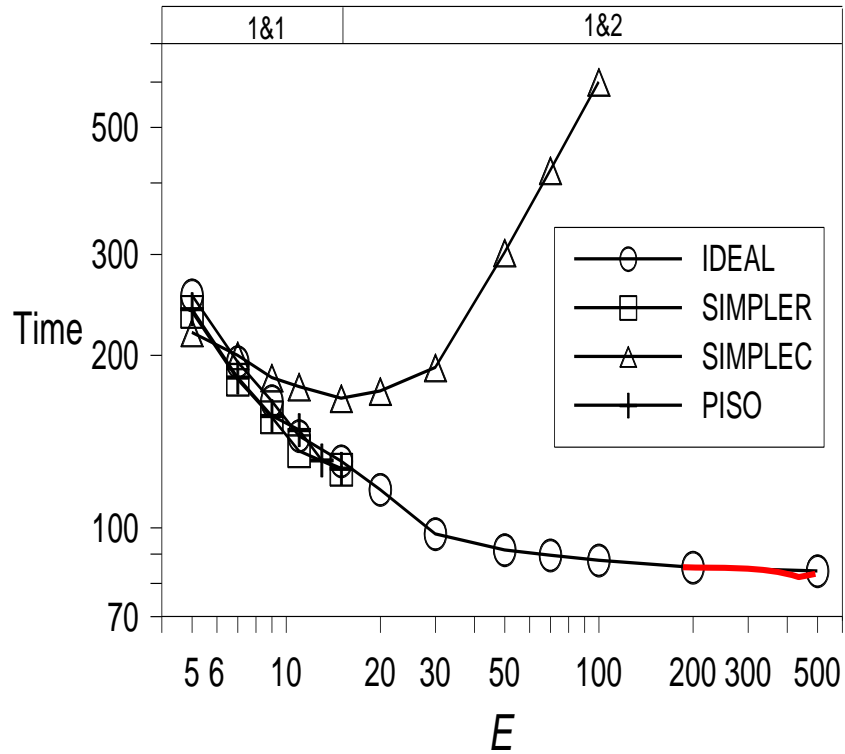

(a)  $Re=100$

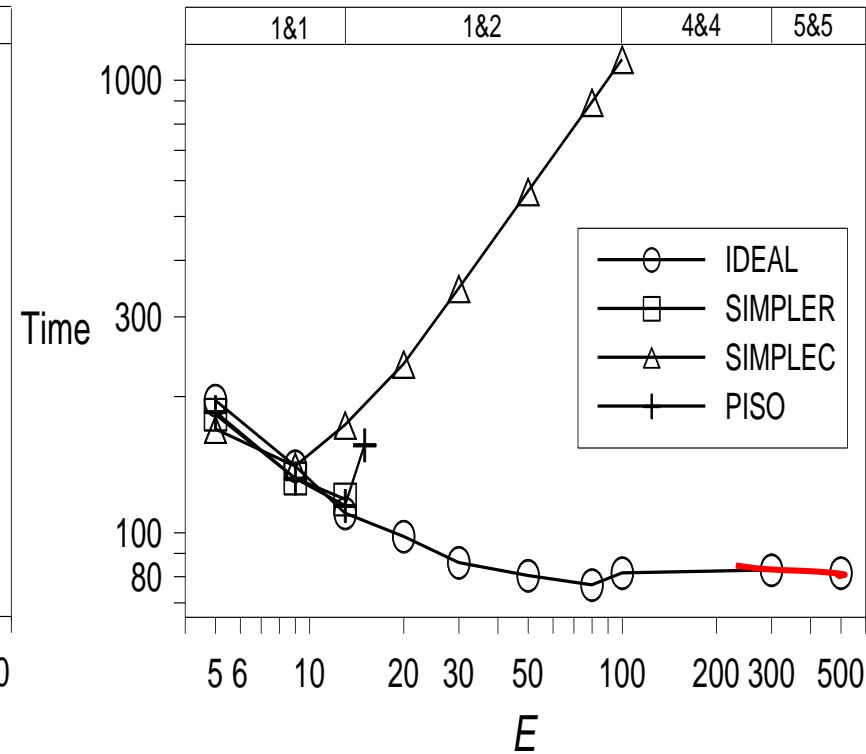

(b)  $Re=500$

**Comparison of computation time and robustness of an ideal algorithm, SIMPLER, SIMPLEC and PISO algorithms for (a)  $Re=100$  and (b)  $Re=500$  with grid number= $52 \times 52 \times 52$**

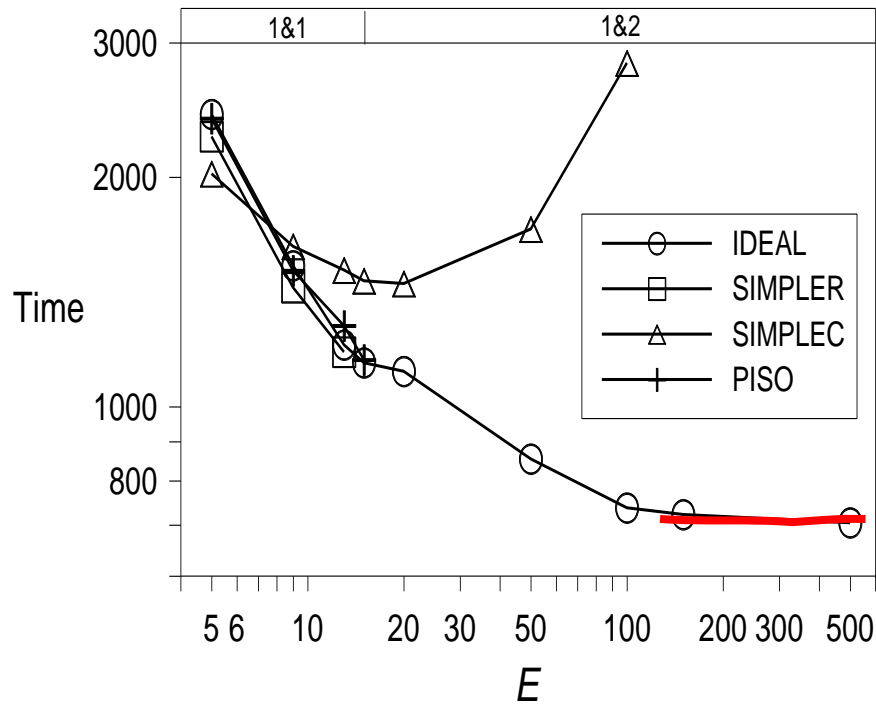

(a)  $Re=100$

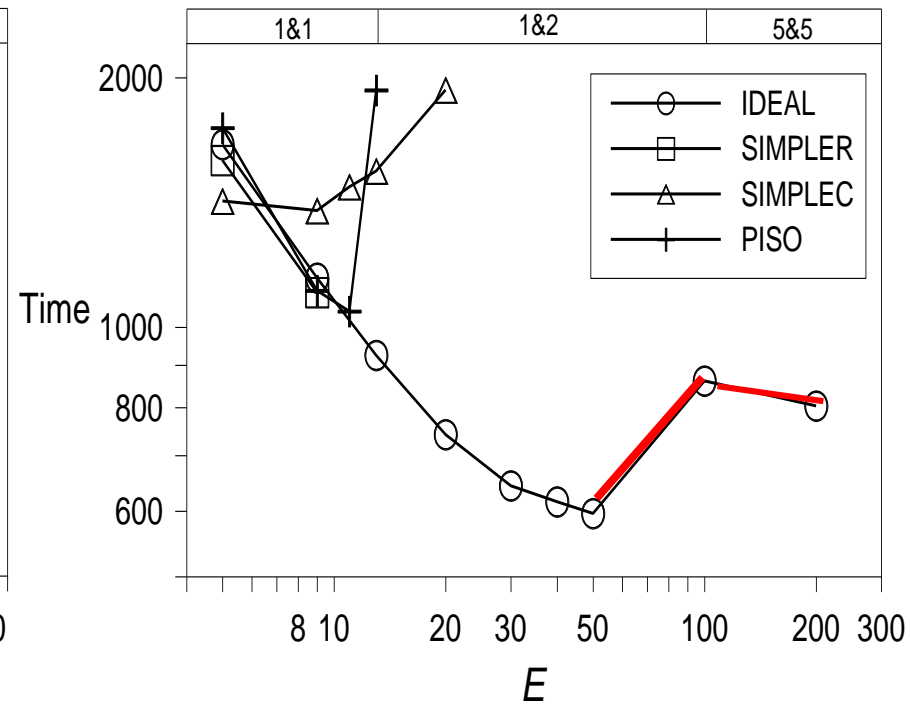

(b)  $Re=1000$

**Comparison of computation time and robustness of an ideal algorithm, SIMPLER, SIMPLEC and PISO algorithms for (a)  $Re=100$  and (b)  $Re=1000$  with grid number= $82 \times 82 \times 82$**



**Reduced ratio of computation time of IDEAL  
algorithm over SIMPLER, SIMPLEC and PISO  
algorithms at their own optimal time step multiples**

| <b>Grid number</b>                     | <b><math>32 \times 32 \times 32</math></b> |            | <b><math>52 \times 52 \times 52</math></b> |            | <b><math>82 \times 82 \times 82</math></b> |             |
|--|--|------------|--|------------|--|-------------|
| <b><i>Re</i></b>                       | <b>100</b>                                 | <b>300</b> | <b>100</b>                                 | <b>500</b> | <b>100</b>                                 | <b>1000</b> |
| <b>Reducing ratio<br/>over SIMPLER</b> | 33.1%                                      | 30.1%      | 33.5%                                      | 35.3%      | 40.3%                                      | 45.9%       |
| <b>Reducing ratio<br/>over SIMPLEC</b> | 54.0%                                      | 46.9%      | 50.0%                                      | 45.3%      | 51.4%                                      | 56.9%       |
| <b>Reducing ratio<br/>over PISO</b>    | 32.1%                                      | 27.3%      | 33.8%                                      | 33.2%      | 38.8%                                      | 43.0%       |

# Problem 6: 3D flow over a back-ward step

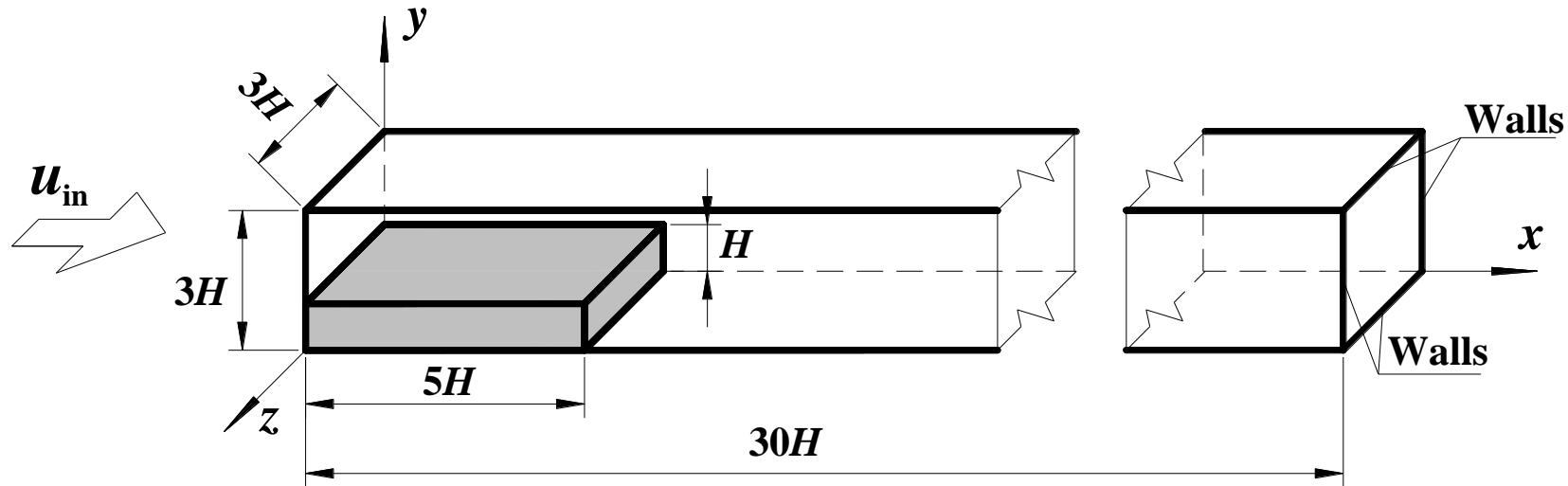

**Flow configuration of laminar fluid flow  
 over a 3-D backward-facing step**

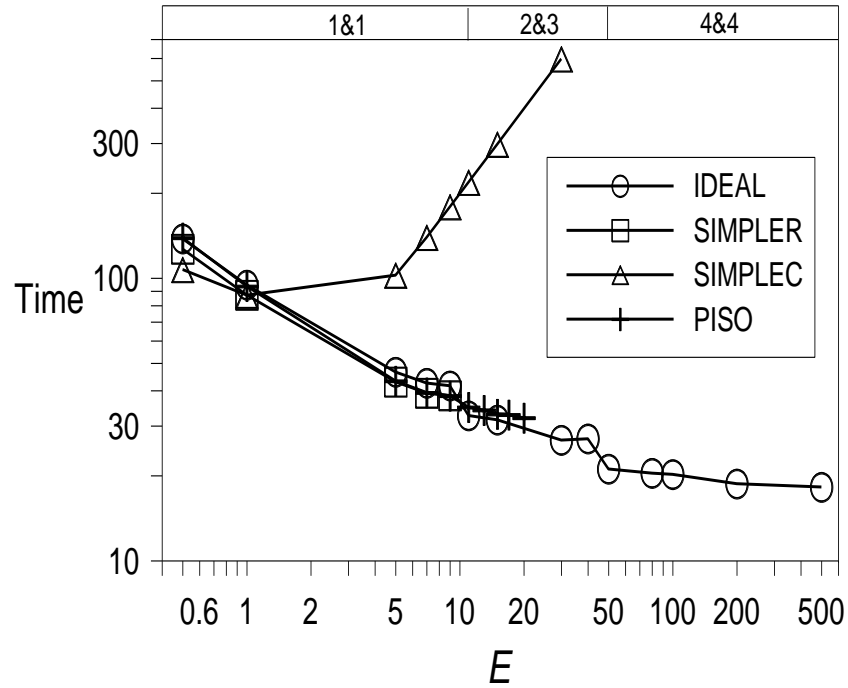

(a)  $Re=100$

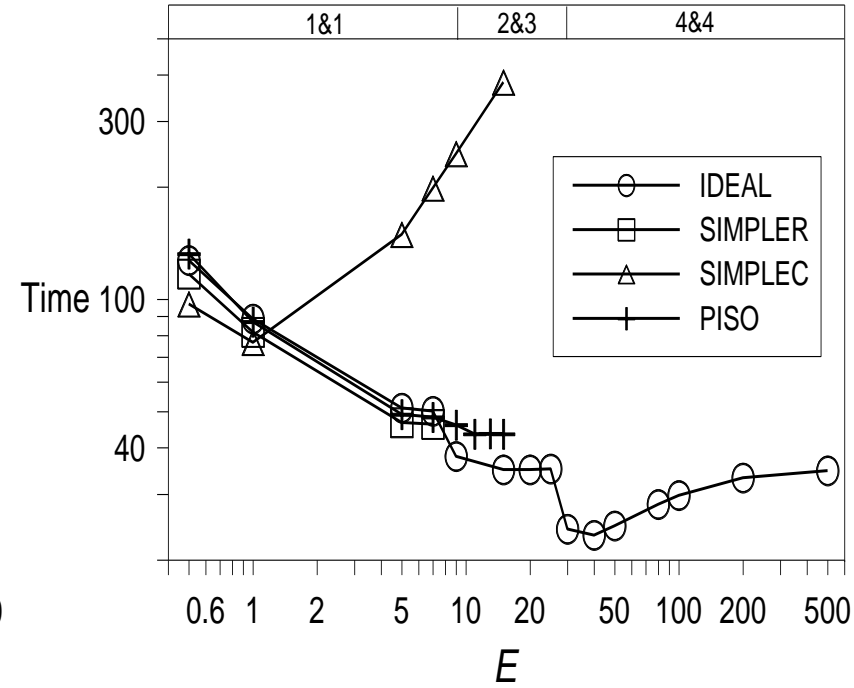

(b)  $Re=300$

**Comparison of computation time and robustness of IDEAL, SIMPLER, SIMPLEC and PISO algorithms for (a)  $Re=100$  and (b)  $Re=300$  with grid number= $80 \times 20 \times 20$**

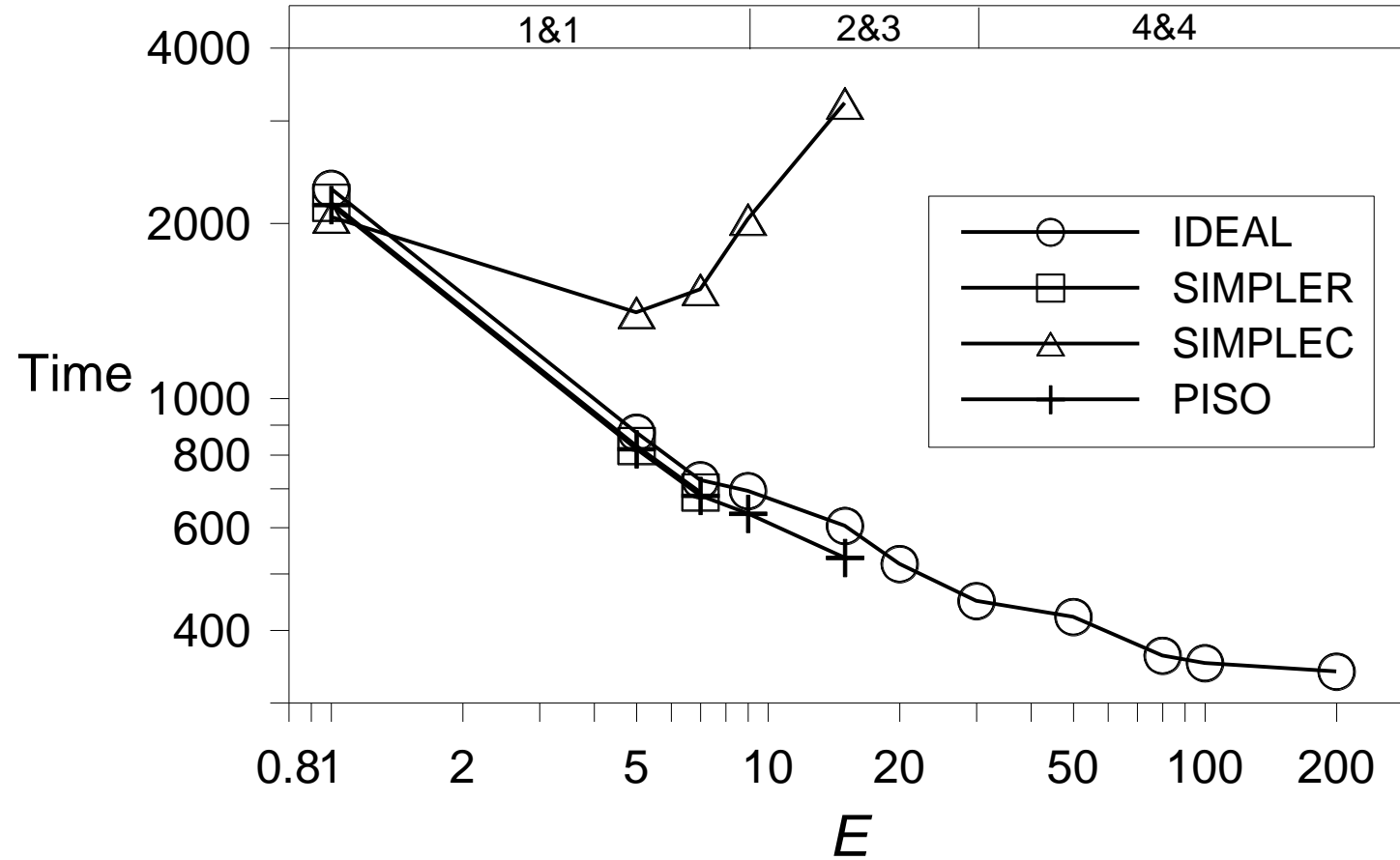

**Comparison of computation time and robustness of IDEAL, SIMPLER, SIMPLEC and PISO algorithms for  $Re=100$  with grid number= $160 \times 41 \times 41$**

## Reducing ratio of computation time of IDEAL algorithm over SIMPLER, SIMPLEC and PISO algorithms at their own optimal time step multiples, i.e., optimal underrelaxation factor

| Grid number                 | <u>80 × 20 × 20</u> |       | <u>160 × 41 × 41</u> |
|-----------------------------|---------------------|-------|----------------------|
| <i>Re</i>                   | 100                 | 300   | 100                  |
| Reducing ratio over SIMPLER | 52.6%               | 49.6% | 50.8%                |
| Reducing ratio over SIMPLEC | 79.1%               | 69.6% | 75.8%                |
| Reducing ratio over PISO    | 43.1%               | 46.5% | 36.3%                |

# Problem 7: 3D natural convection in enclosure

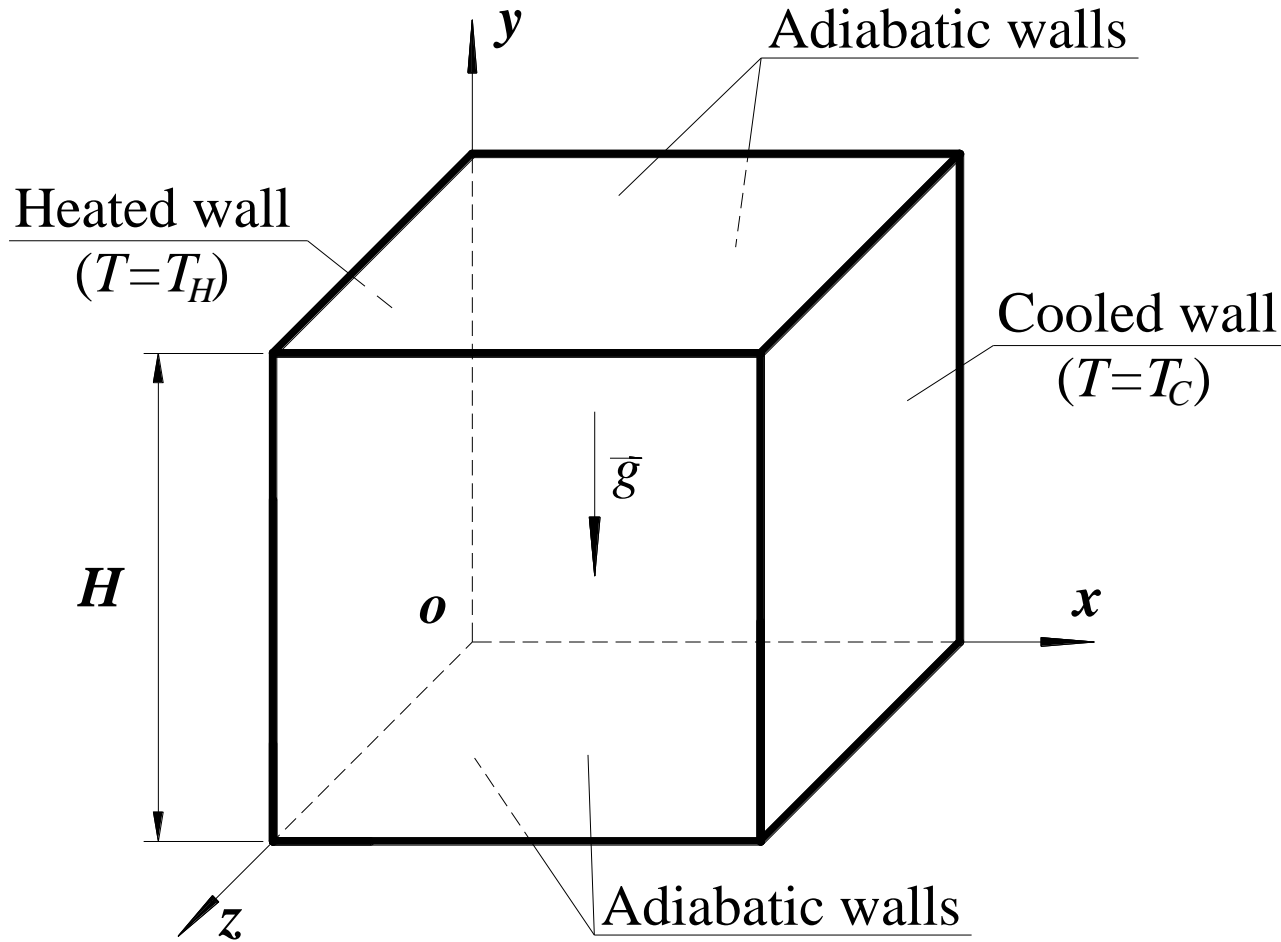

**Flow configuration of natural convection in a cubic cavity.**

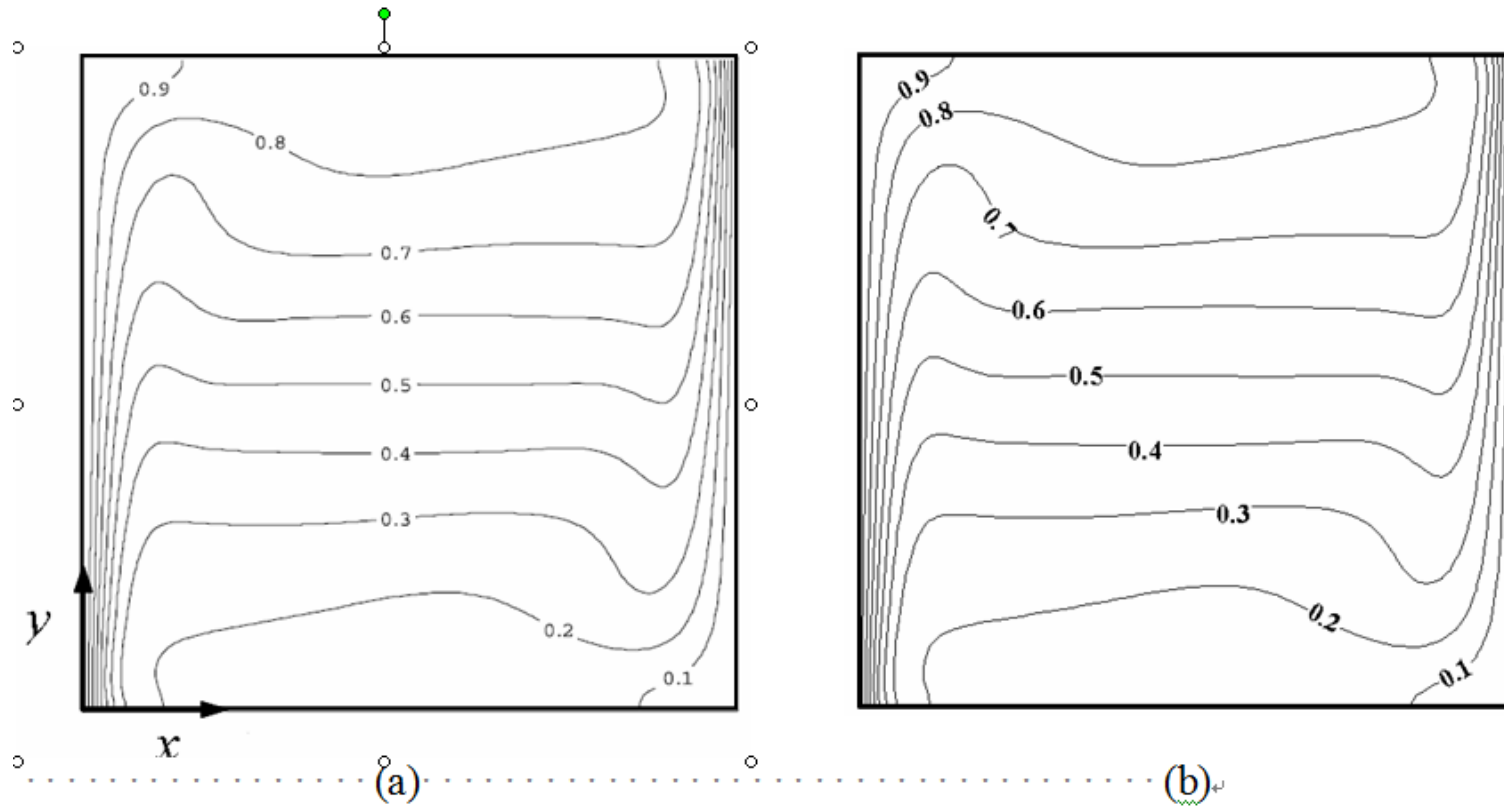

**Temperatures at the plane  $z=0.5H$  for  $Ra=10^6$ , obtained (a) from reference , (b) by IDEAL algorithm**

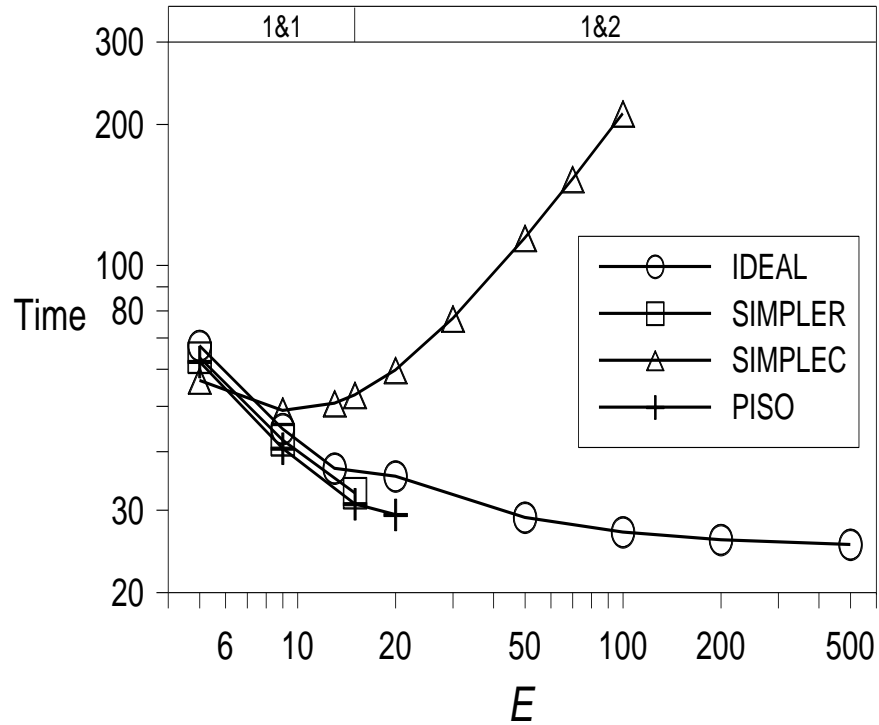

**Comparison of computation time and robustness for  $Ra=10^4$  with grid number= $30 \times 30 \times 30$**

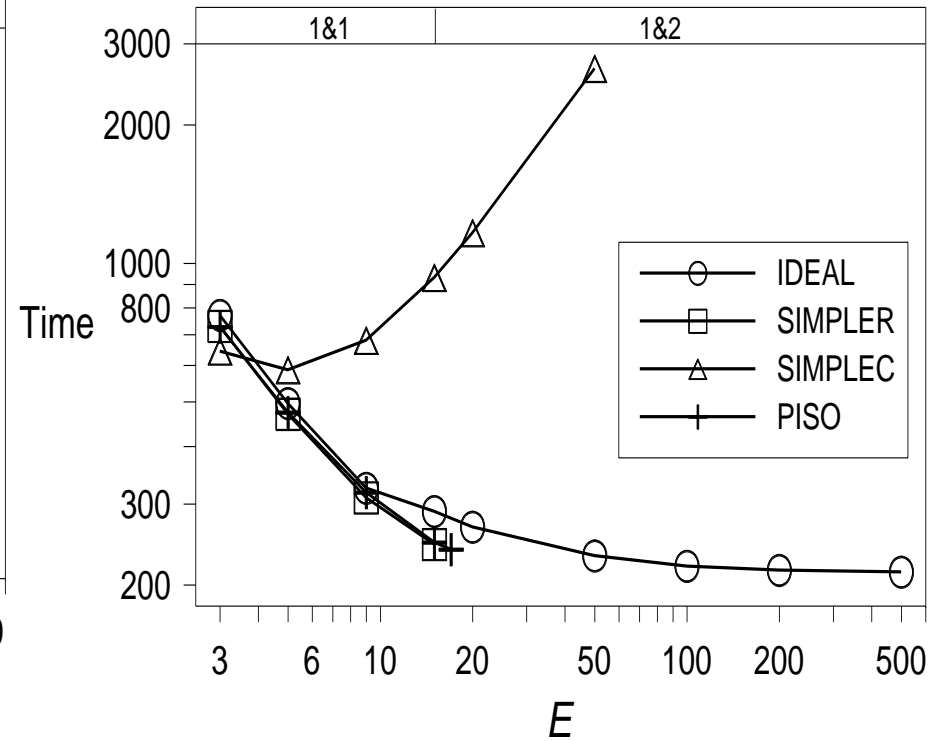

**Comparison of computation time and robustness for  $Ra=10^5$  with grid number= $50 \times 50 \times 50$**



## Problem 8: 3D flow over a back-ward step with complex structure

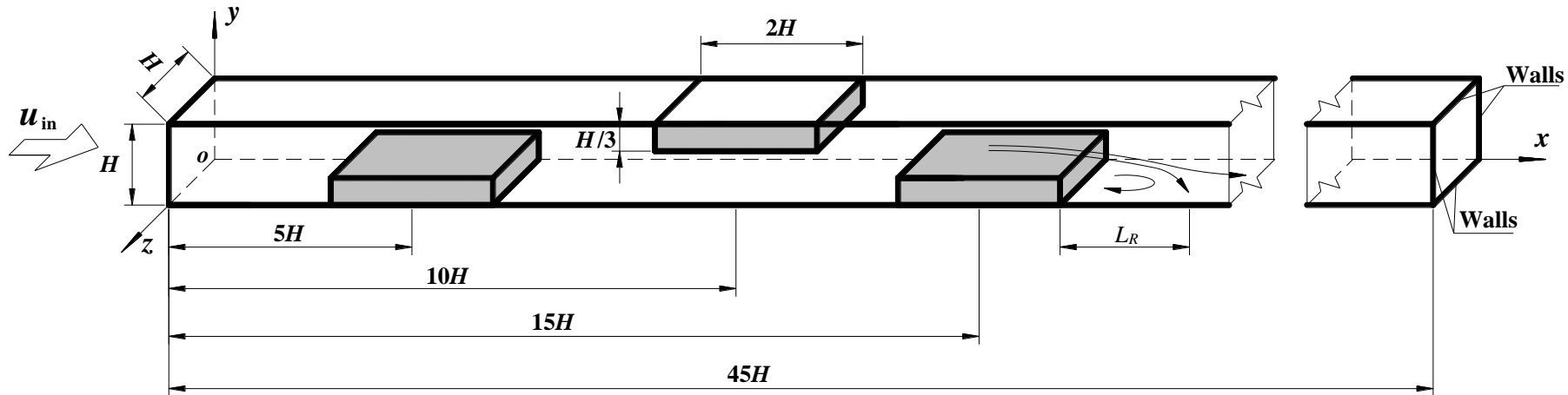

Flow configuration of laminar fluid flow through a 3-D duct with complicated structure

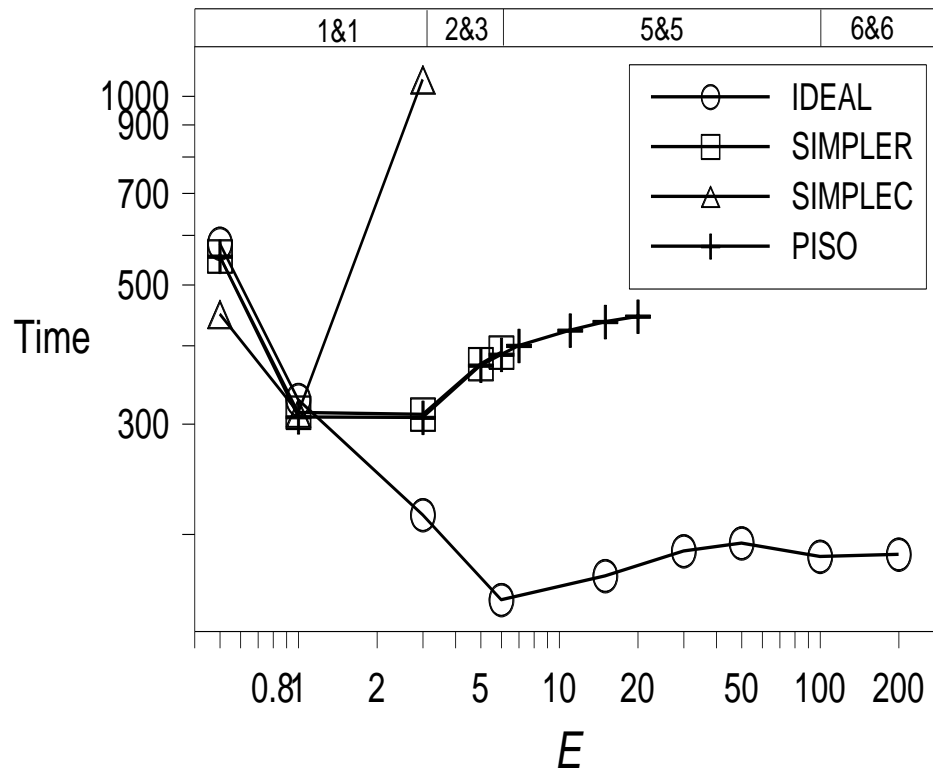

(a)  $Re=100$

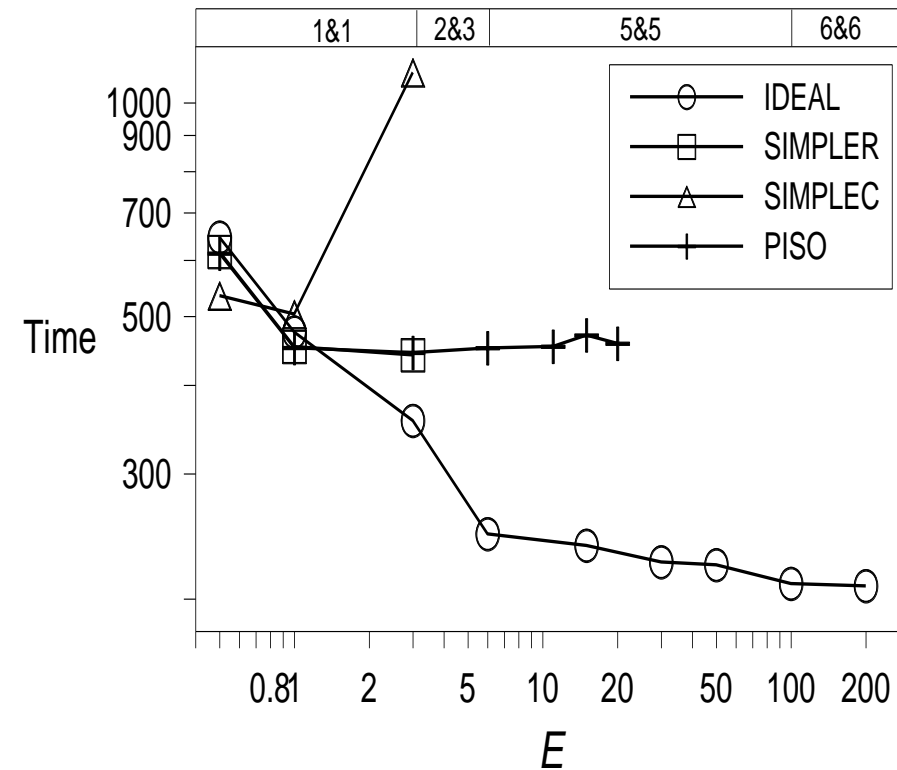

(b)  $Re=300$

**Comparison of computation time and robustness with grid  
number= $150 \times 20 \times 20$**

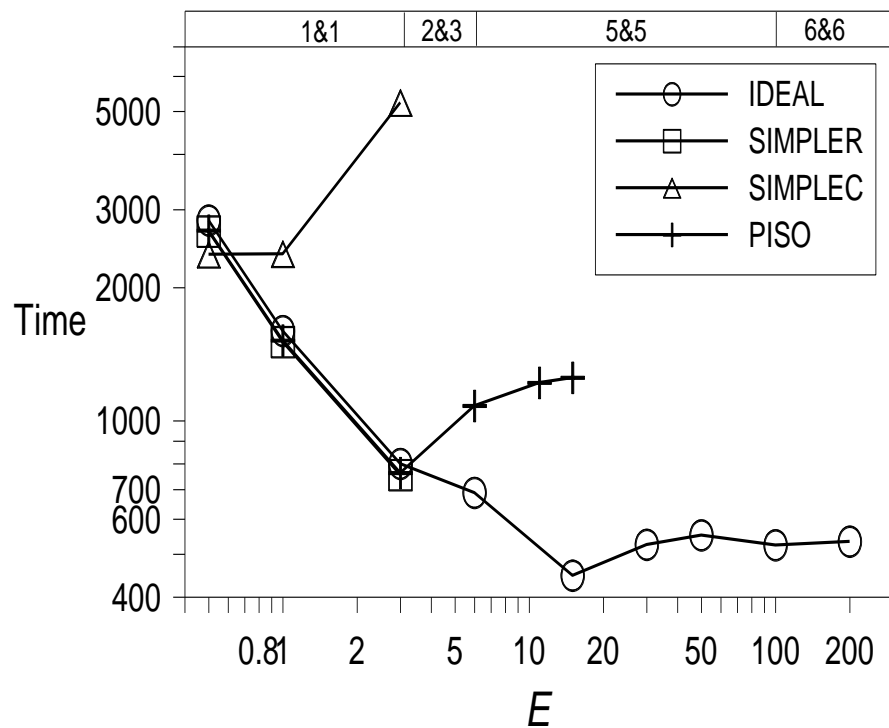

(a)  $Re=100$

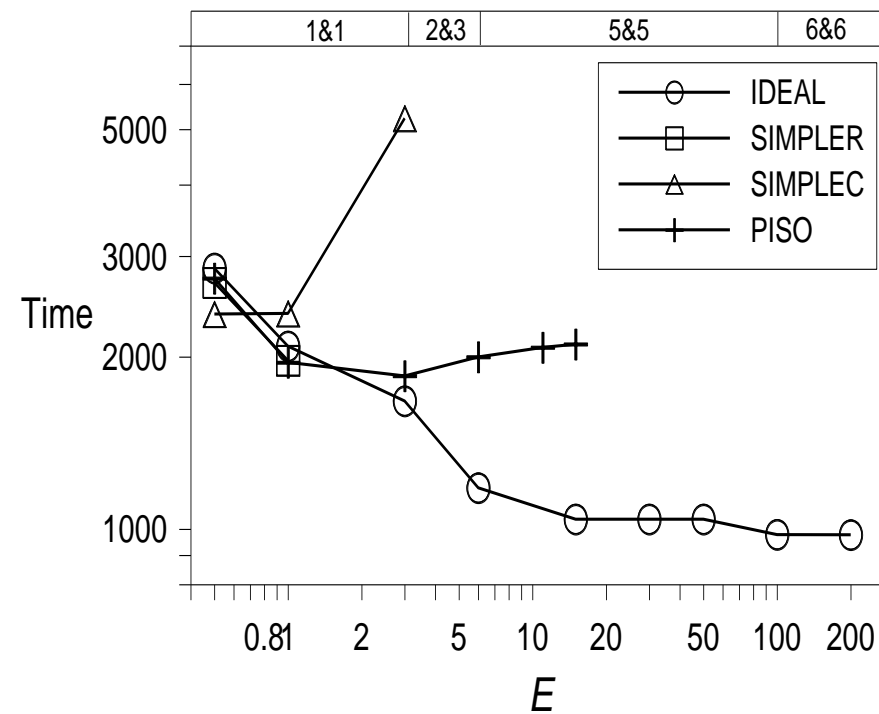

(b)  $Re=500$

Comparison of computation time and robustness with grid number= $190 \times 29 \times 29$

# Problem 9: 3D lid-driven flow in a complex cavity

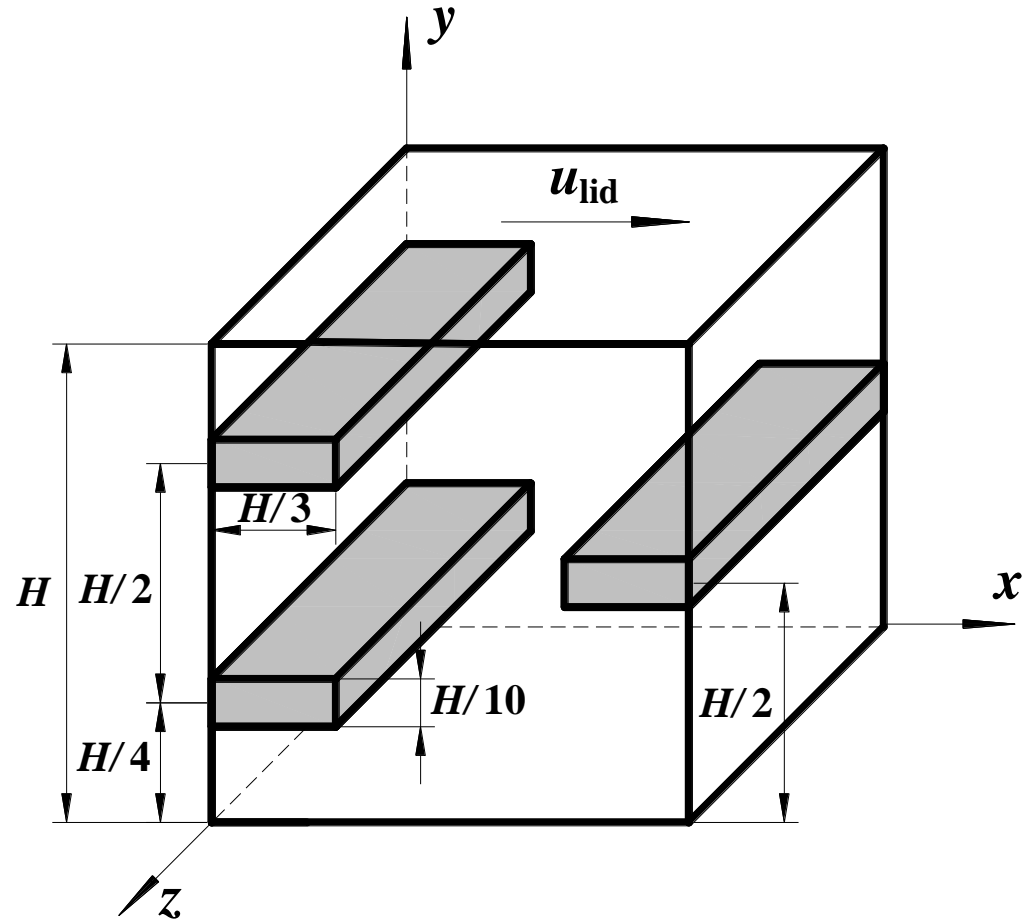

**Flow configuration of lid-driven cavity flow in a cubic cavity with complicated structure**

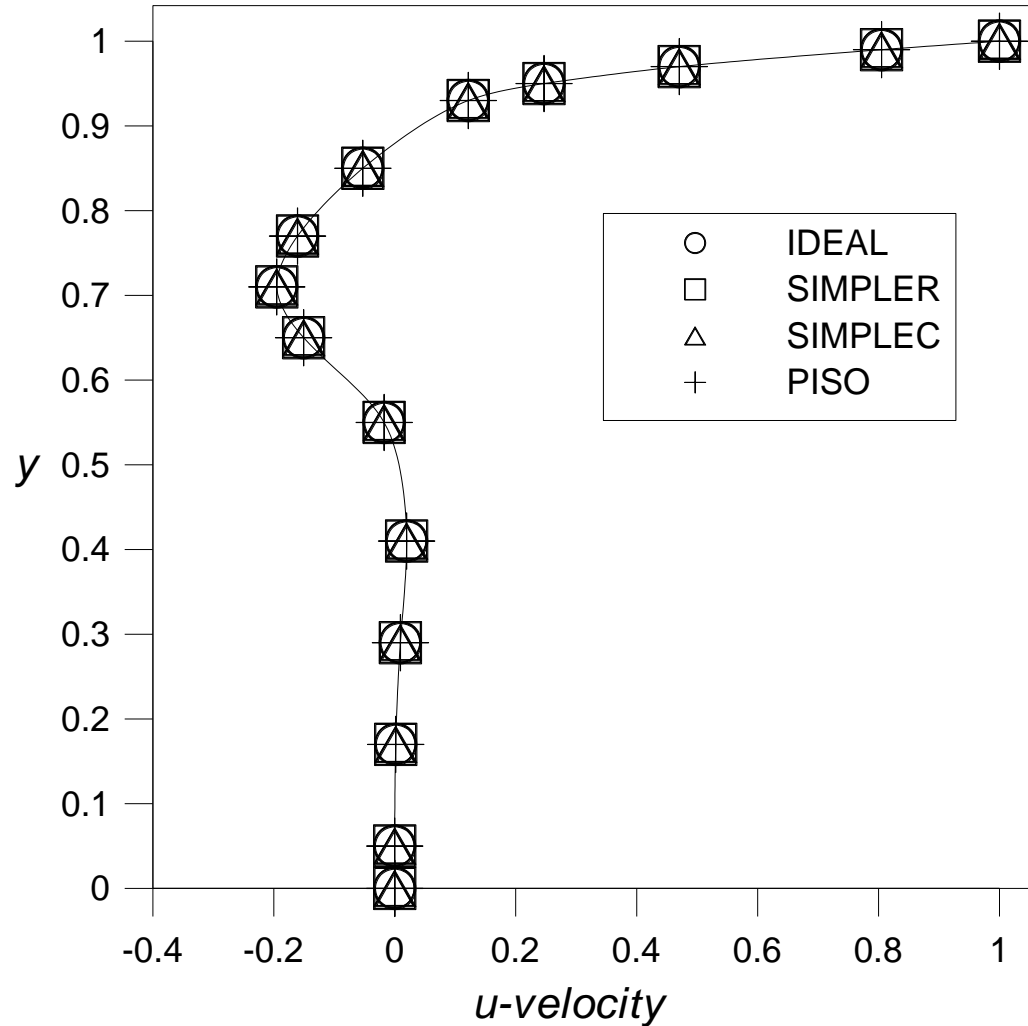

各种算法收敛时的结果应该相同---  
算法比健壮性;  
格式比数值解的精度。

**Comparison of velocity profiles  $u$  along the central axes  $y$  on plane  $z=0.5H$  for  $Re=500$ .**

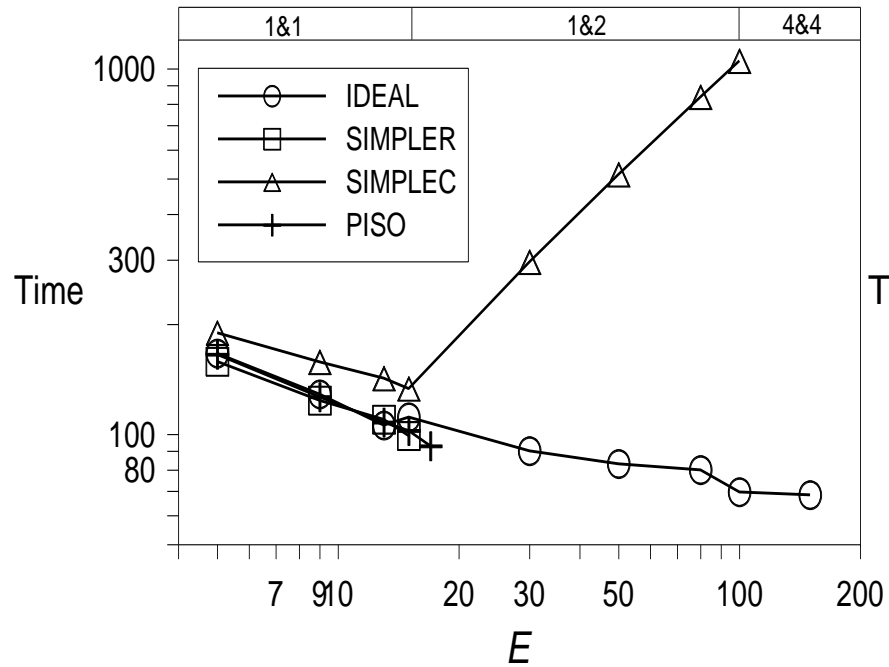

(a)  $Re=100$

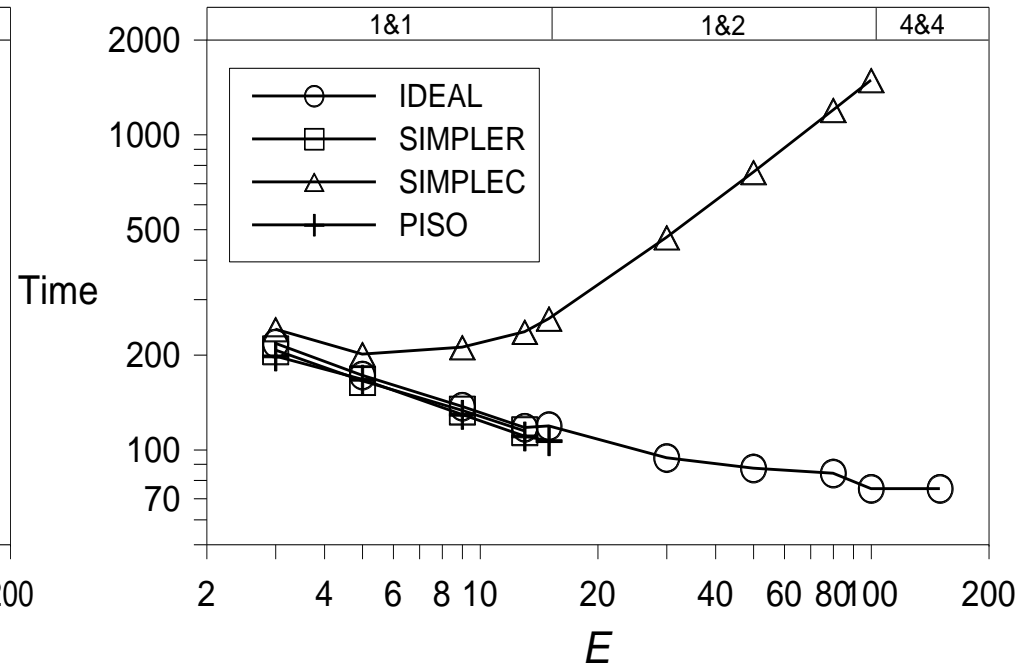

(b)  $Re=500$

**Comparison of computation time and robustness with grid  
number= $52 \times 52 \times 52$**

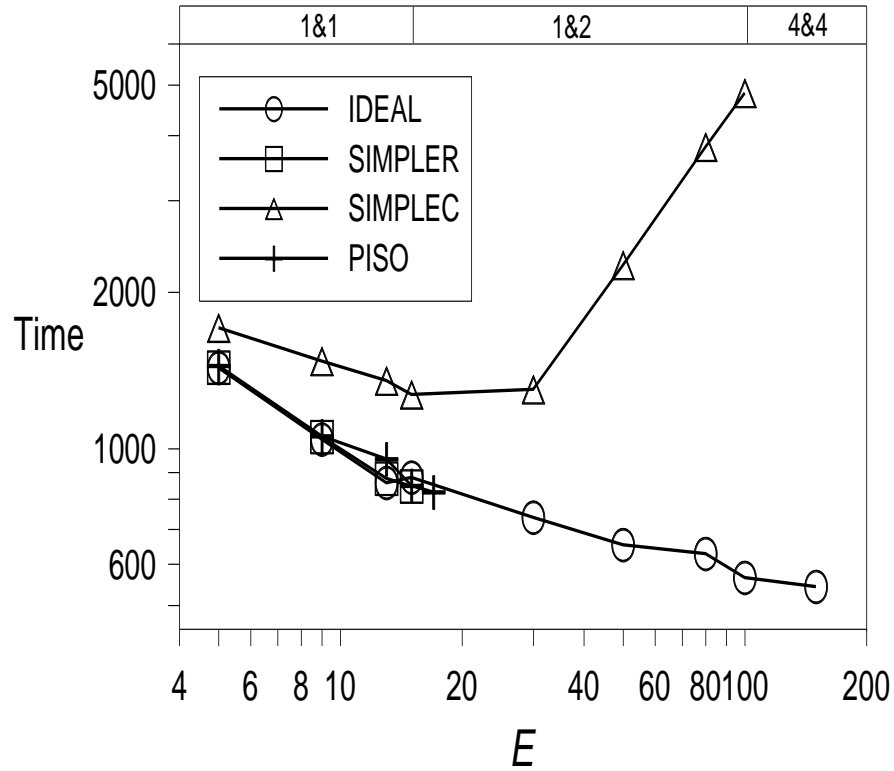

**(a)  $Re=100$**

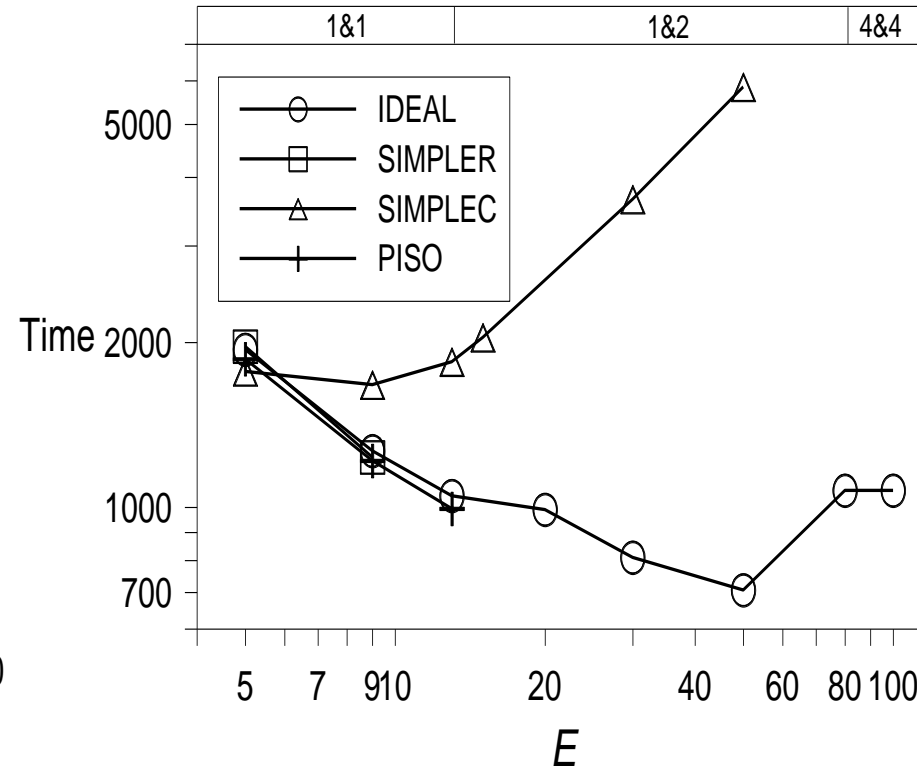

**(b)  $Re=800$**

**Comparison of computation time and robustness with  
grid number= $82 \times 82 \times 82$**

### 3. Discussion of the IDEAL algorithm

**1) The pressure and velocity equations are solved by inner doubly-iterative methods. Thus it is called Inner Doubly-iterative Efficient Algorithm for Linked-equations (IDEAL)**

**2) The conservation condition of mass and momentum is almost fully satisfied at each iteration level, the velocity and pressure under-relaxation factors may be set to a quite large value and need not to be adjusted. A value of 0.9 (and even 1.0) for both the velocity and pressure under-relaxation factors can be used.**



**3) The inner doubly-iterative times  $N1$ ,  $N2$  need to be adjusted so that the conservation of mass and momentum can be almost fully guaranteed at each iteration level. In our study, the inner doubly-iterative times  $N1$  and  $N2$  are usually set as 4;**

**For some situations such as very high- $Re/Ra$  or very fine-mesh flow cases larger values may be needed.**

**Wang (王金萍) et al. proposed a self-adaptive method for adjusting the values of  $N1$ ,  $N2$ .**

**4) The IDEAL algorithm can be regarded as a multi-step solution algorithm in both prediction and correction stages.**

# Extension of the IDEAL algorithm to 3D, body-fitted coordinates and compressible flows have been completed.

Sun DL, Qu Z G, He Y L, Tao WQ. An efficient segregated algorithm for incompressible fluid flow and heat transfer problems-IDEAL (Inner doubly iterative efficient algorithm for linked equation) Part I:Mathematical formulation and solution. **Numerical Heat Transfer, Part B**, 2008,53(1);1-17

## 推荐阅读(10)

Sun DL, Qu Z G, He Y L, Tao WQ. An efficient segregated algorithm for incompressible fluid flow and heat transfer problems-IDEAL (Inner doubly iterative efficient algorithm for linked equation) Part II:Application examples. **Numerical Heat Transfer, Part B**, 2008,53(1);18-38

Jin-Ping Wang, Jian-Fei Zhang, Zhi-Guo Qu & Wen-Quan Tao. Adaptive inner iteration processes in pressure based method for viscous compressible flows, **Numerical Heat Transfer, Part B**, 2018, 74(3): 603–622

## 推荐阅读(11)

解决了IDEAL算法中N1,N2的自适应选取问题

## 3.4 FVM中松弛因子的自动取值方法

### 3.4.1 压力修正方法中松弛因子选取概述

### 3.4.2 松弛因子自动选取方法的基本思想

### 3.4.3 松弛因子自动选取计算公式的推导

### 3.4.4 自动选取方法的应用例子

## 3.4 FVM求解方法中松弛因子的自动取值方法

### 3.4.1 压力修正方法中松弛因子选取概述

在流场求解过程中由于问题的非线性，需要采用亚松弛，而且亚松弛过程是组织到迭代过程中的。二维动量方程离散形式为：

$$a_P (u_i)_P = \sum a_{nb} (u_i)_{nb} + b \quad (i = 1, 2, P \text{表示速度所在的位置})$$

把松弛过程组织到迭代过程中（隐式亚松弛）

$$\left( \frac{a_P}{\alpha_u} \right) (u_i)_P = \sum a_{nb} (u_i)_{nb} + b + (1 - \alpha_u) \frac{a_P}{\alpha_u} (u_i)_P^{old}$$

松弛因子影响计算的收敛性及健壮性！常见取值方法：

- (1)  $\alpha_u + \alpha_p = c \quad c = 1.0-1.1; \quad \alpha_u = 0.7-0.8$
- (2) SOAR method (Optimized and Automated Relaxation Factors)  
 (Numerical Heat Transfer, Part B, 2000,38:309-332 )
- (3) 模糊控制方法(Fuzzy control)(Numer. Heat Transfer B ,2004, 46: 301-327)

所有上述方法都没有从为什么要亚松弛这个最根本的问题出发去研究，因此都缺乏一般性！

## 7.4.2 松弛因子自动选取方法的基本思想

### 1. 用时步倍率代替亚松弛因子

$$E = \frac{\alpha_u}{1 - \alpha_u}; \frac{1}{E} = \frac{1 - \alpha_u}{\alpha_u}; \frac{1}{E} = \frac{1}{\alpha_u} - 1; \frac{1}{\alpha_u} = \frac{1}{E} + 1 \quad \alpha: 0 \rightarrow 1; E: 0 \rightarrow \infty \quad (1)$$

将亚松弛过程组织到迭代过程中去时，有：

$$\left( \frac{a_P}{\alpha_u} \right) (u_i)_P = \sum a_{nb} (u_i)_{nb} + b + (1 - \alpha_u) \frac{a_P}{\alpha_u} (u_i)_P^{old} \quad (i = 1, 2)$$

$$\left( a_P + \frac{a_P}{E} \right) (u_i)_P = \sum a_{nb} (u_i)_{nb} + b + \frac{a_P}{E} (u_i)_P^{old}$$

### 2. 导出自适应亚松弛因子计算式的一些基本考虑

(1) **从对流项与扩散项的作用考虑：**流场求解的非线性是由对流项引起的：求解变量速度在不断地变化；纯扩散方程的求解甚至可以采用超松弛来加速收敛，**扩散项增加求解健壮性；**

(2) **从亚松弛迭代计算式考虑：**在亚松弛迭代求解公式中的  $\frac{a_P}{E}(u_i)_P^{old}$  项起增加求解过程健壮的作用，其值越大迭代不宜发散但收敛越慢；非线性项变化越大，收敛越快，**但越容易发散。**

**自适应的亚松弛因子应当在能增加求解健壮性的(亚松弛项+扩散项)与能加快收敛速度的非线性项变化之间找到一个平衡。**

### 3. 导出自适应亚松弛因子的关键处理

(1) 把邻点的影响系数分拆为扩散与对流两部分；

(2) 为能适用于不同的对流项离散格式，统一采用迎风差分，不同的格式用延迟修正考虑。

### 3.4.3 松弛因子自动选取计算公式的推导

#### 1. 把对流与扩散的影响分开

$$\left( a_P + \frac{a_P}{E} \right) (u_i)_P = a_E (u_i)_E + a_W (u_i)_W + a_N (u_i)_N + a_S (u_i)_S + b + \frac{a_P}{E} (u_i)_P^{old} \quad (2)$$

$$a_E = \frac{\Gamma_e \Delta y}{\delta x_e} + \max \left[ -(\rho u_1)_e \Delta y, 0 \right] \quad a_W = \frac{\Gamma_w \Delta y}{\delta x_w} + \max \left[ (\rho u_1)_w \Delta y, 0 \right]$$

$u_1, u_2$  表示  $u, v$

$$a_N = \frac{\Gamma_n \Delta x}{\delta y_n} + \max \left[ -(\rho u_2)_n \Delta x, 0 \right] \quad a_S = \frac{\Gamma_s \Delta x}{\delta y_s} + \max \left[ (\rho u_2)_s \Delta x, 0 \right]$$

$$b = S_c \Delta x \Delta y + S_{ad} \quad a_P = a_E + a_W + a_N + a_S - S_p \Delta x \Delta y$$

$$\begin{aligned} S_{ad} = & -\max \left[ (\rho u)_e \Delta y, 0 \right] (\phi_e - \phi_P)^{old} + \max \left[ -(\rho u)_e \Delta y, 0 \right] (\phi_e - \phi_E)^{old} \\ & -\max \left[ -(\rho u)_w \Delta y, 0 \right] (\phi_w - \phi_P)^{old} + \max \left[ (\rho u)_w \Delta y, 0 \right] (\phi_w - \phi_W)^{old} \\ & -\max \left[ (\rho v)_n \Delta x, 0 \right] (\phi_n - \phi_P)^{old} + \max \left[ -(\rho v)_n \Delta x, 0 \right] (\phi_n - \phi_N)^{old} \\ & -\max \left[ -(\rho v)_s \Delta x, 0 \right] (\phi_s - \phi_P)^{old} + \max \left[ (\rho v)_s \Delta x, 0 \right] (\phi_s - \phi_S)^{old} \end{aligned}$$

$\phi_e, \phi_w, \phi_n, \phi_s$   
表示高阶格式  
的界面插值

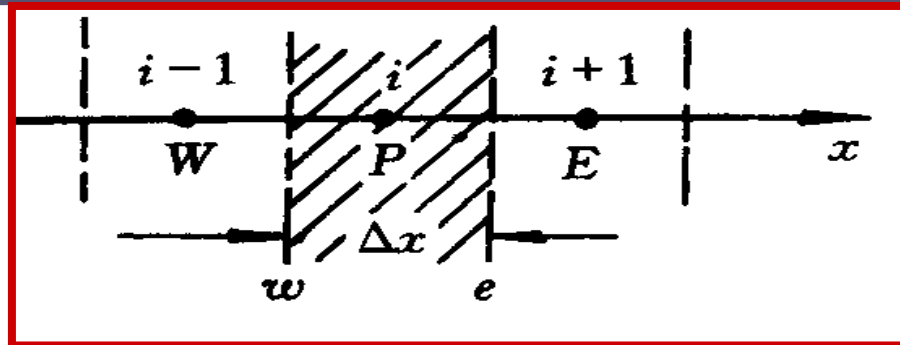

流速大于零时，一阶迎风的  
 的界面插值  $\phi_e = \phi_P$ ;

流速小于零时，一阶迎风的  
 的界面插值  $\phi_e = \phi_E$

$$\begin{aligned}
 S_{ad} = & -\max [(\rho u)_e \Delta y, 0] (\phi_e - \phi_P)^{old} + \max [-(\rho u)_e \Delta y, 0] (\phi_e - \phi_E)^{old} \\
 & -\max [-(\rho u)_w \Delta y, 0] (\phi_w - \phi_P)^{old} + \max [(\rho u)_w \Delta y, 0] (\phi_w - \phi_W)^{old} \\
 & -\max [(\rho v)_n \Delta x, 0] (\phi_n - \phi_P)^{old} + \max [-(\rho v)_n \Delta x, 0] (\phi_n - \phi_N)^{old} \\
 & -\max [-(\rho v)_s \Delta x, 0] (\phi_s - \phi_P)^{old} + \max [(\rho v)_s \Delta x, 0] (\phi_s - \phi_S)^{old}
 \end{aligned}$$



把式 (2) 中的影响系数表示为扩散与对流两部分:

$$\left( a_P + \frac{a_P}{E} \right) (u_i)_P = \underline{A_P^D (u_i)_P^D + A_P^C (u_i)_P^C} + b + \frac{a_P}{E} (u_i)_P^{old} \quad (3)$$

$$A_P^D (u_i)_P^D = a_E^D (u_i)_E + a_W^D (u_i)_W + a_N^D (u_i)_N + a_S^D (u_i)_S$$

$$A_P^C (u_i)_P^C = a_E^C (u_i)_E + a_W^C (u_i)_W + a_N^C (u_i)_N + a_S^C (u_i)_S$$

$$a_E^D = \frac{\Gamma_e \Delta y}{\delta x_e} \quad a_W^D = \frac{\Gamma_w \Delta y}{\delta x_w} \quad a_N^D = \frac{\Gamma_n \Delta x}{\delta y_n} \quad a_S^D = \frac{\Gamma_s \Delta x}{\delta y_s}$$

$$a_E^C = \max \left[ -(\rho u_1)_e \Delta y, 0 \right] \quad a_W^C = \max \left[ (\rho u_1)_w \Delta y, 0 \right]$$

$$a_N^C = \max \left[ -(\rho u_2)_n \Delta x, 0 \right] \quad a_S^C = \max \left[ (\rho u_2)_s \Delta x, 0 \right]$$

$$b = S_c \Delta x \Delta y + S_{ad}$$

$$a_P = A_P^D + A_P^C - S_p \Delta x \Delta y$$

$$A_P^D = a_E^D + a_W^D + a_N^D + a_S^D \quad A_P^C = a_E^C + a_W^C + a_N^C + a_S^C$$

式 (3) 中  $A_p^D$ ,  $A_p^C$ ,  $a_p/E$  分别反映了扩散, 对流及亚松弛的影响; **离散方程是对流、扩散及亚松弛三项的加权组合!**

自适应的亚松弛因子应当在能增加求解健壮性的(亚松弛项+扩散项)与能加快收敛速度的非线性项变化之间找到一个平衡。

## 2. 对流项变化的相对影响及亚松弛项的相对影响

扩散项的作用是增加迭代稳定性的, 而对流项的变化是引起非线性的原因, 因此以下的相对比值可以表征两者的相对影响:

$$R_C = \left| A_p^C - (A_p^C)^{old} \right| / A_p^D \quad (4)$$

亚松弛项  $a_p/E$  越大, 亚松弛影响越大; 亚松弛是为减轻对流项非线性造成影响的, 因此可构造比值  $R_U$

$$R_U = (a_p/E) / A_p^C \quad (5)$$

比值  $R_U$  反应了起稳定作用的亚松弛项的影响

### 3. 自适应亚松弛因子应满足的条件

$R_C$  增加, 非线性增加, 可使收敛加快;  $R_U$  增加稳定性增加, 但是收敛速度变慢; 一个合适的亚松弛因子需在两者间求得平衡, 因此应有:

$$R_C = R_U \quad \left| A_P^C - (A_P^C)^{old} \right| / A_P^D = (a_P / E) / A_P^C \quad (6)$$

将式 (1) 代入 (6), 对  $\alpha$  解出, 得:

$$\frac{1}{E} = \frac{1}{\alpha_u} - 1 \quad (1);$$

$$\alpha = \frac{A_P^C + A_P^D - S_p \Delta x \Delta y}{\left( \frac{\left| A_P^C - (A_P^C)^{old} \right|}{A_P^D} + 1 \right) A_P^C + A_P^D - S_p \Delta x \Delta y} \quad (7a)$$

$$a_P = A_P^D + A_P^C - S_p \Delta x \Delta y$$

首先对上式做定性分析，是否满足亚松弛因子  $\leq 1$  的要求，显然是满足的；

$$\alpha = \frac{A_p^C + A_p^D - S_p \Delta x \Delta y}{\left( \frac{|A_p^C - (A_p^C)^{old}|}{A_p^D} + 1 \right) A_p^C + A_p^D - S_p \Delta x \Delta y}$$

但上式隐含一种危险性：当非线性不强烈时，可能

$$\left| A_p^C - (A_p^C)^{old} \right| \approx 0$$

使得  $\alpha \approx 1$ ；为避免这种情况，作者提出在分母中  $A_p^D$  的系数从 1 增加到 2：

$$\alpha_u = \frac{A_p^C + A_p^D - S_p \Delta x \Delta y}{\left( \frac{|A_p^C - (A_p^C)^{old}|}{A_p^D} + 1 \right) A_p^C + 2A_p^D - S_p \Delta x \Delta y} \quad (7b)$$

# 3.4.4 自适应松弛因子选取公式应用举例

## 1. 顶盖驱动流

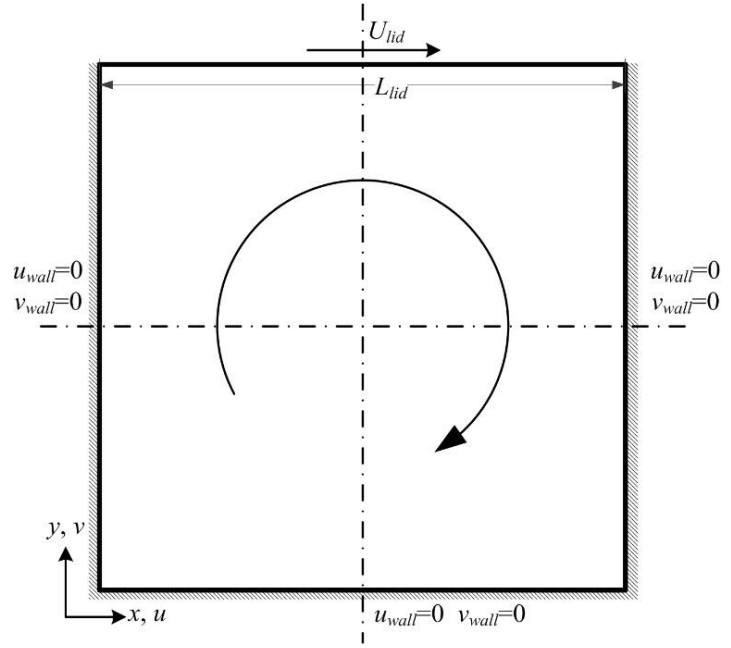

无论松弛因子怎么选  
取，收敛的解应该相同！

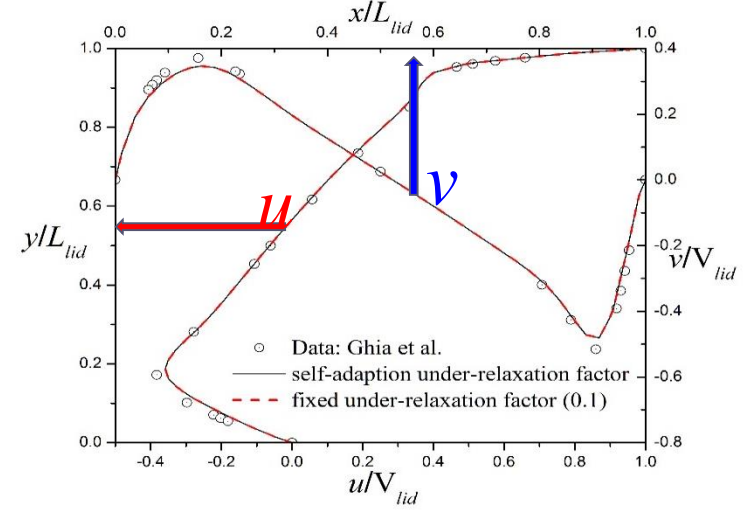

Re=1000 in 40 × 40 grid

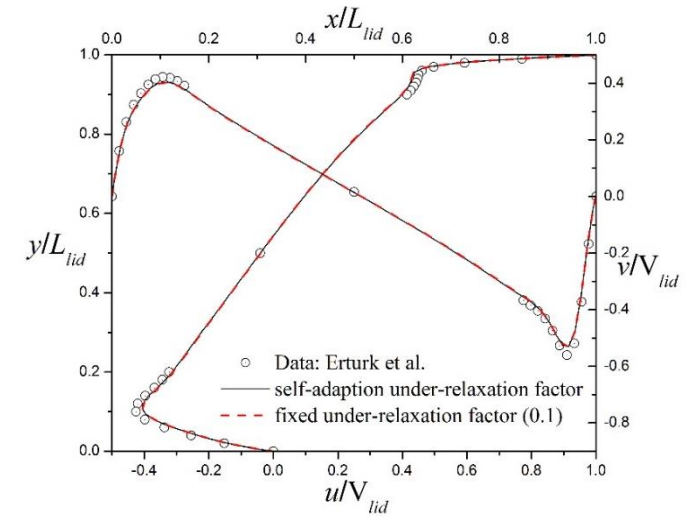

Re=2500 in 80 × 80 grid

## 固定松弛因子及自适应松弛因子下收敛时间之比

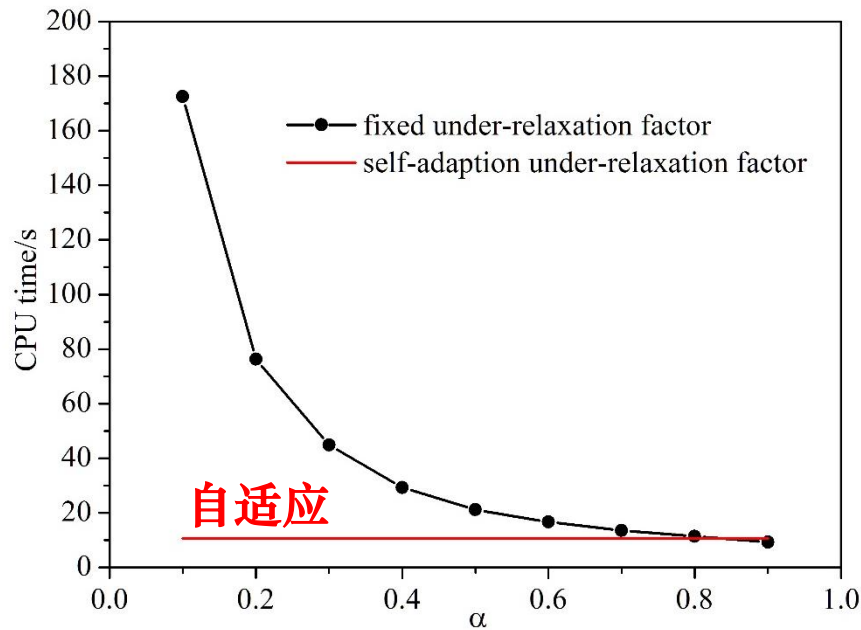

Re=1000 in 40 × 40 grid

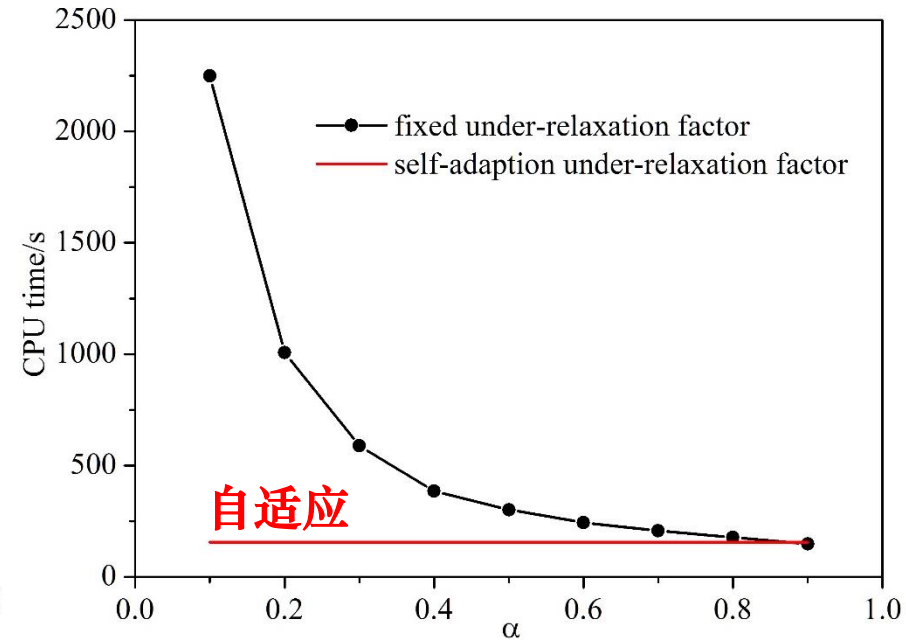

Re=2500 in 80 × 80 grid

## 固定松弛因子及自适应松弛因子下收敛历史的对比

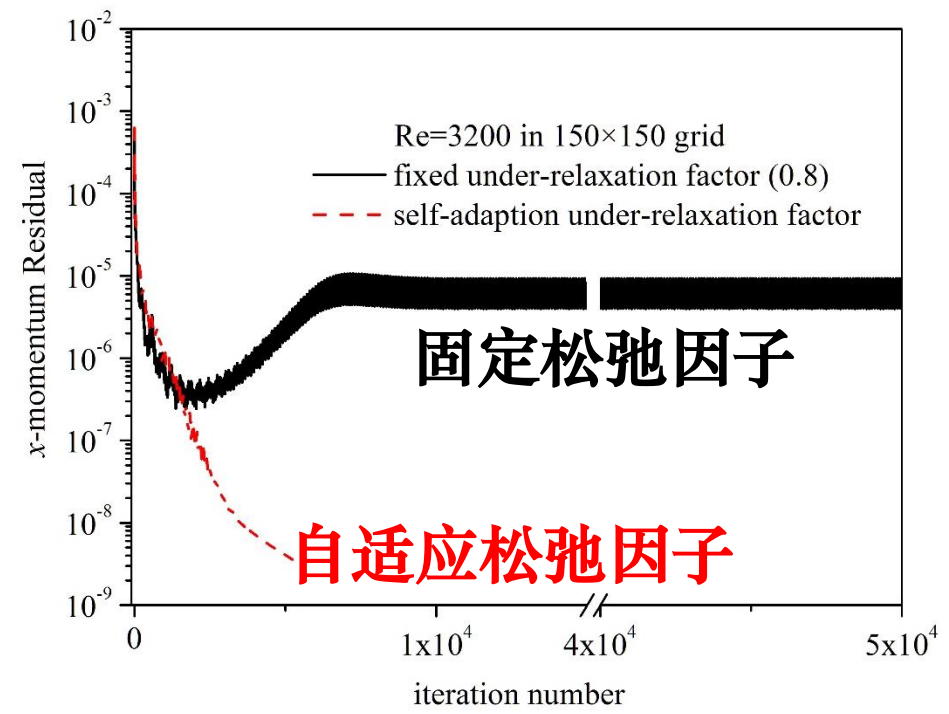
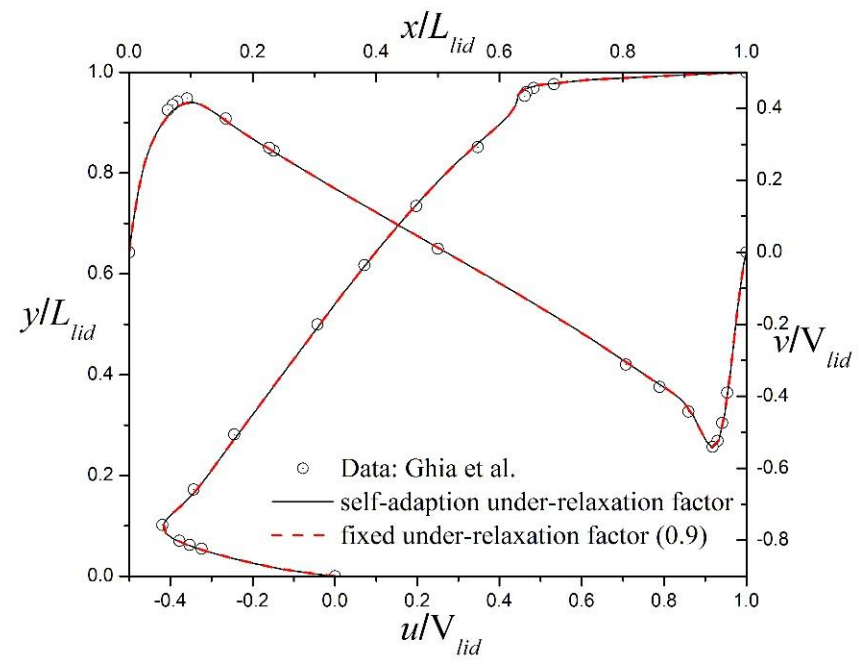

$Re=3200$  in  $100 \times 100$  grid

## 2. 后台阶流动

$$Re = u_{in} D / \nu$$

$$D = 2h_i$$

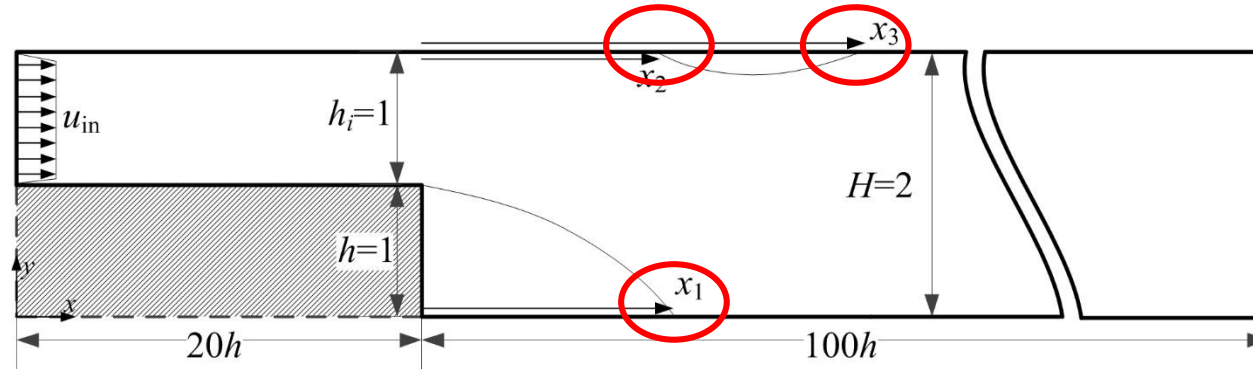

| Re  |       | Erturk | $\alpha_u=0.9$ | self-adaptation |
|-----|-------|--------|----------------|-----------------|
| 200 | $x_1$ | 4.982  | 5.124          | 5.124           |
|     | $x_2$ | —      | —              | —               |
|     | $x_3$ | —      | —              | —               |
| 400 | $x_1$ | 8.237  | 8.388          | 8.388           |
|     | $x_2$ | 7.731  | 7.691          | 7.691           |
|     | $x_3$ | 10.037 | 9.813          | 9.813           |
| 500 | $x_1$ | 9.420  | 9.476          | 9.476           |
|     | $x_2$ | 8.013  | 7.877          | 7.877           |
|     | $x_3$ | 13.171 | 12.966         | 12.970          |

无论松弛因子怎么选，收敛的解应该相同！

E. Erturk, Numerical solutions of 2-D steady incompressible flow over a backward-facing step, Part I: High Reynolds number solutions, Comput. Fluids 37 (2008) 633-655.



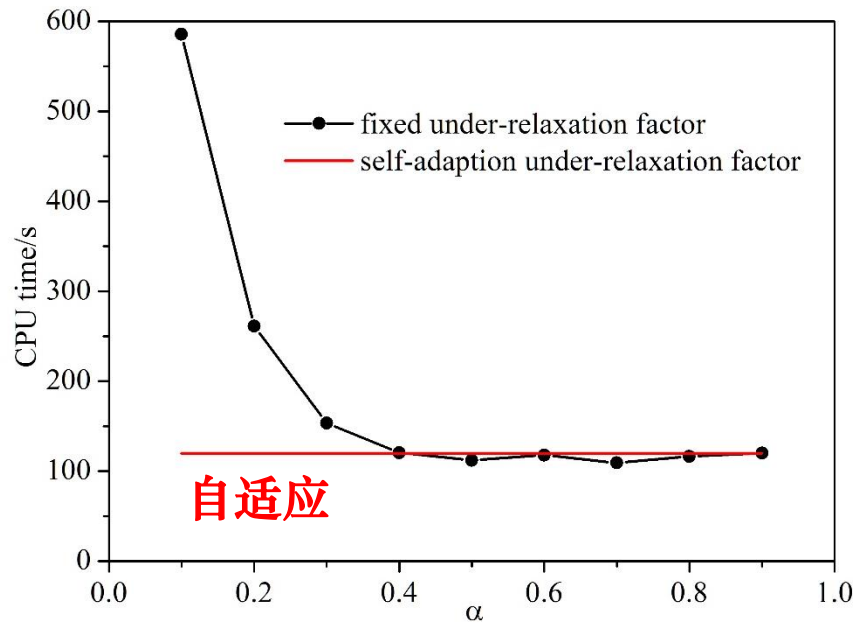

Re=200 in  $120 \times 30$  grid

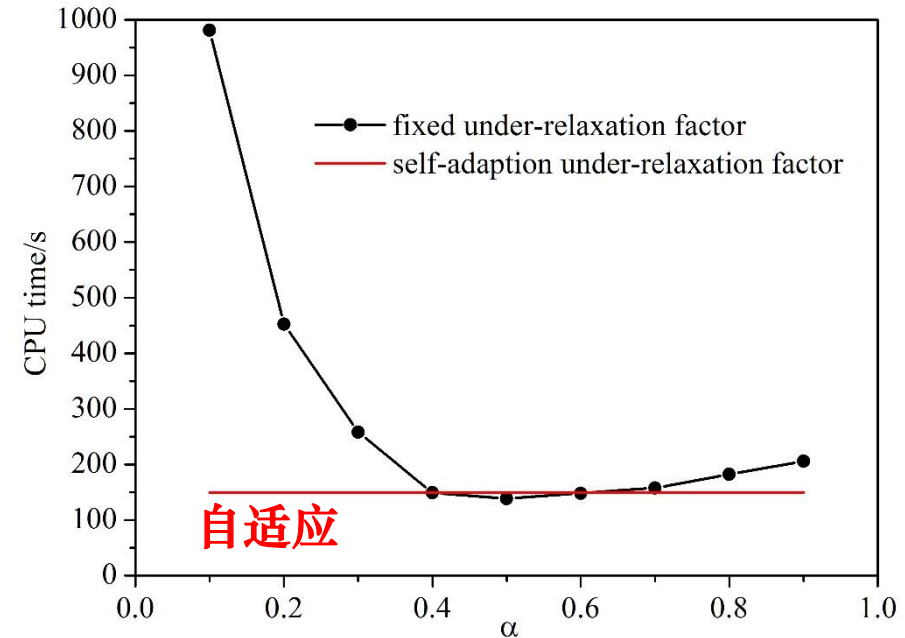

Re=400 in  $120 \times 30$  grid

Wei You, Zeng-Yao Li & Wen-Quan Tao. A general self-adaptive under-relaxation strategy for fast and robust convergence of iterative calculation of incompressible flow. Numerical Heat Transfer, Part B: Fundamentals. 2020, 77(4): 299–310

**推荐阅读(12)**

**第一作者：尤伟，现为珠海市数舟科技有限公司CFD商业软件开发负责人。**

## 3.5 FVM中的同位网格

### 3.5.1 不可压缩流场求解中压力与速度存储位置的演变

### 3.5.2 交叉网格成功的经验

### 3.5.3 在非交叉网格上控制方程的离散

### 3.5.4 界面压力及流量的MIM插值

## 3.5 FVM中的同位网格

### 3.5.1 不可压缩流场求解中压力与速度存储位置的演变

上世纪60年代为了克服流场求解中出现波形压力场（棋盘型）压力场的问题，引入了交叉网格，就是将压力与速度不存储在同一个位置上，交叉网格在CFD/NHT中成功地被广泛采用了二，三十年；

但是随着计算机硬件技术及数值计算方法的深入发展交叉网格的缺点逐渐显现，例如对三维问题的代数方程采用多重网格方法求解，对  $u, v, w, p$  四个变量，每个4套网格，共需16套网格；对于非结构化网格更是难以执行；

于是研究者提出了在同一套网格上存储所有变脸而又能克服波形压力场的网格系统，称为同位网格（collocated grid system）.

历史上，1981年Minnesota大学Patankar教授的两个博士Hsu及Prakash以及Chicago大学Chow教授的博士Rhie分别在其博士学位论文中提出了相关的方法，但没有引起重视；到1988年Peric等三人在Computers & Fluids 上发表文章，此后同位网格的研究与应用上就迅速得到发展，目前已经成为非结构化网格系统的唯一选择。

Peric M, Kessler R, Scheurer G., Comparison of finite volume numerical methods with staggered and collocated grids, Computers & Fluids, 1988,16:389-401 **推荐阅读 (13)**

从一套网格  $\longrightarrow$  交叉网格  $\longrightarrow$  同位网格的发展历程体现了螺旋式的实物发展过程个！

### 3.5.2 交叉网格成功的经验

#### 交叉网格成功的经验—引入 $1-\delta$ 压差及 $O(\delta^2)$

$1-\delta$  压差可有效地克服不合理的波形压力分布；

$O(\delta^2)$  保证不可压缩流体压力 Poisson 方程的扩散特性。

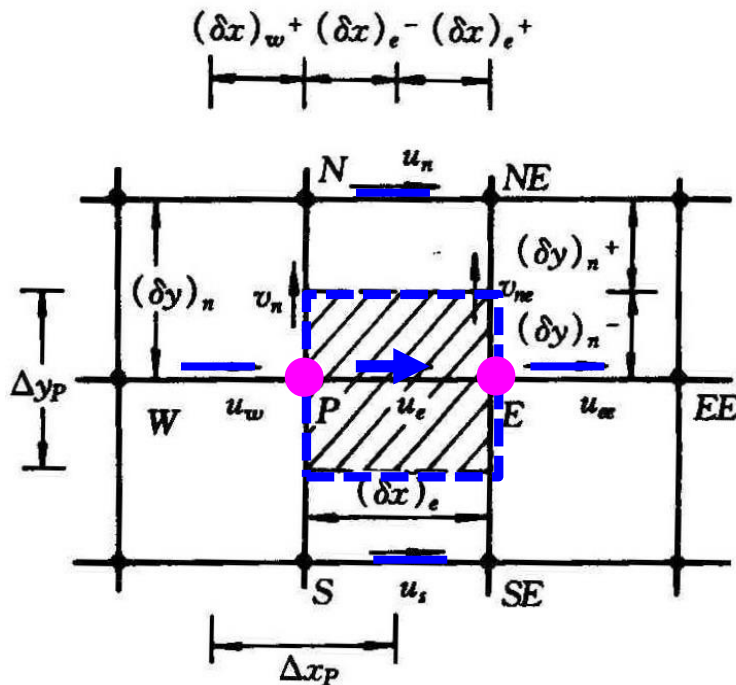

$$\left(\frac{\partial p}{\partial x}\right)_{u_e} = \frac{p_E - p_P}{(\delta x)}, O(\delta x^2)$$

交叉网格

### 3.5.3 在非交叉网络上控制方程的离散

#### (1) 动量守恒

$$a_P u_P = \sum_{E,W,N,S} a_{nb} u_{nb} + b - A_P (p_e - p_w)$$

$$u_P = \frac{\sum a_{nb} u_{nb} + b}{a_P} - \frac{A_P}{a_P} (p_e - p_w)$$

$$u_P = u_P - \frac{A_P}{a_P} (p_e - p_w)$$

类似地

$$u_E = u_E - \left( \frac{A_P}{a_P} \right)_E (p_e - p_w)_E$$

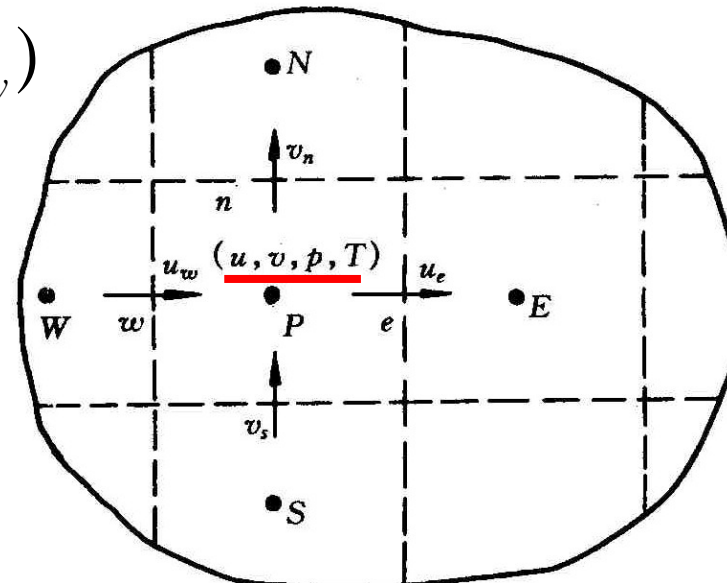

对E点写出其东、西界面压差

## (2) 质量守恒

对主节点控制容积写出，  
需要用到未知的界面流速  
(在交叉网格上有界面流速)：

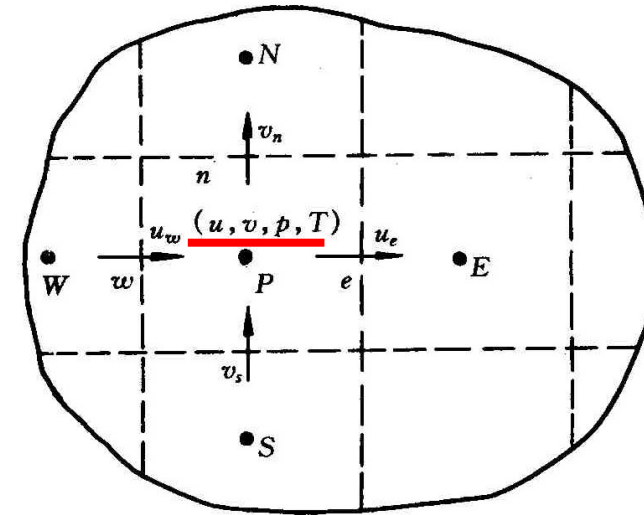

$$(\rho u A)_e - (\rho u A)_w + (\rho v A)_n - (\rho v A)_s = 0$$

## (3) 界面压力及流速的确定

在上述离散过程中引入了界面压力及流量，这些信息在非交叉网格的控制容积界面上是不存在的，需要从其附近的节点插值而得。



## 3.5.4 界面压力及流量的插值

### 1) 界面压力插值

$$a_P u_P = \sum_{E,W,N,S} a_{nb} u_{nb} + b - A_P (p_e - p_w)$$

#### (1) 线性插值 (均分网格)

$$p_e = 0.5(p_P + p_E)$$

#### (2) 其它插值方式

对于非结构化网格，在Fluent中还介绍了更多的插值方式，按照FVM格式的定义（界面之值用节点表示的方式），在Fluent中也称为压力离散的格式。

特别注意，在Fluent中有所谓的**PRESTO**格式，其实就是交叉网格：**PRE**ssure **ST**aggering **O**ption!

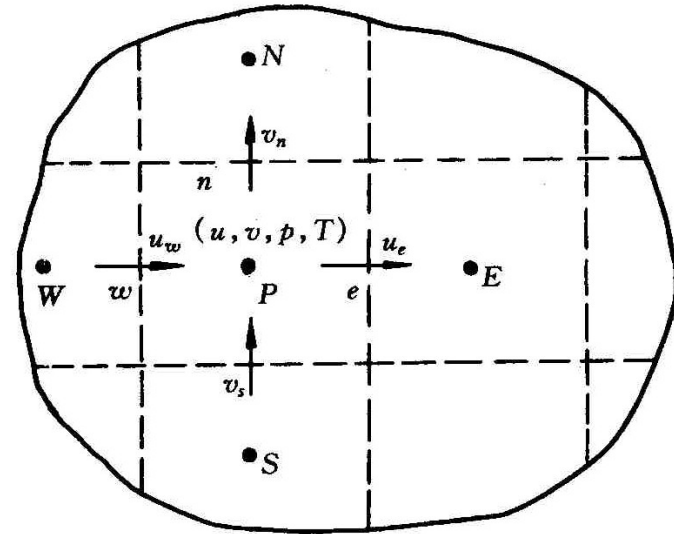



## 2) 界面流量的插值

就是这个界面流速的确定为引入  $1 - \delta$  压差提供了途径:

模仿  $u_P, u_E$  的计算式: 
$$u_P = u_P - \left(\frac{A_P}{a_P}\right)(p_e - p_w)_P$$

$P$  节点两侧界面间的压差

类似地，试将界面流速表示为:

$$u_e = u_e - \left(\frac{A_P}{a_P}\right)_e (p_E - p_P)$$

$e$  界面的东、西邻点压差

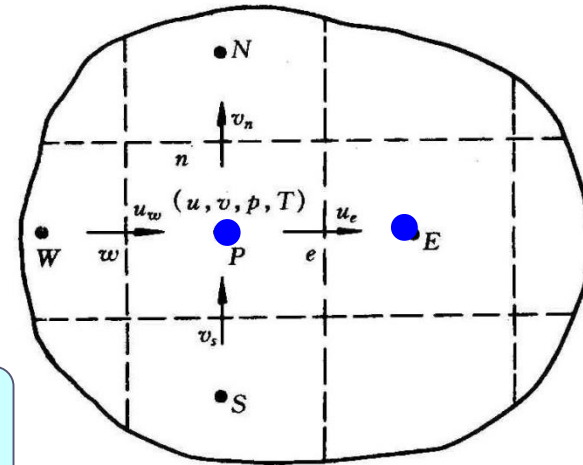

上式也是可视为界面流速的动量方程。

Rhie-Chow引入了这种对界面流速的确定方式，称为**动量插值**(momentum interpolation method-MIM)，是解决同位网格上压力波动的关键技术。

如果界面流速表示为  $u_P, u_E$  间的线性插值，则就失去了引入相邻两点间压差的机会！

同位网格中MIM网格界面上  $u_e, \left(\frac{A_P}{a_P}\right)_e$  均采用线性插值计算公式，即根据  $u_P, u_E$  计算式中的对应项来计算：

$$u_P = \underbrace{u_P}_{\text{circled}} - \frac{A_P}{a_P} (p_e - p_w) \quad \underbrace{u_E}_{\text{circled}} = u_E - \left(\frac{A_P}{a_P}\right)_E (p_e - p_w)_E$$

### 线性插值

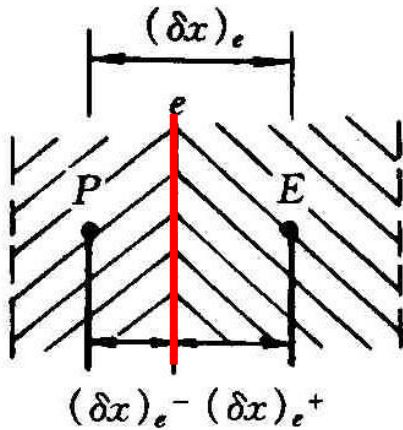

界面流速采用MIM插值的非交叉网格称为**同位网格**!

$$\left. \begin{aligned}
 u_e &= u_P \frac{(\delta x)_{e^+}}{(\delta x)_e} + u_E \frac{(\delta x)_{e^-}}{(\delta x)_e} \\
 \left(\frac{A_P}{a_P}\right)_e &= \left(\frac{A_P}{a_P}\right)_P \frac{(\delta x)_{e^+}}{(\delta x)_e} + \left(\frac{A_P}{a_P}\right)_E \frac{(\delta x)_{e^-}}{(\delta x)_e}
 \end{aligned} \right\}$$

以这样的界面流速计算式代入质量守恒方程，就能得出与交叉网格中类似的压力和压力修正值方程。

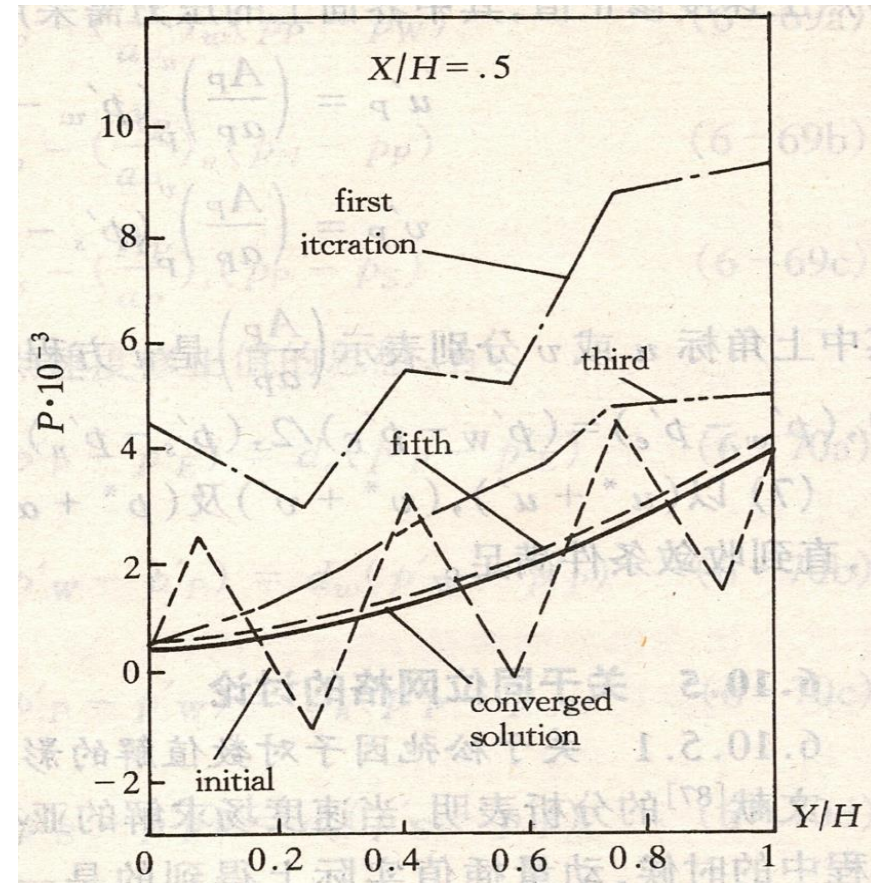

同位网格有效性的数值验证举例

## 3.6 非结构化网格上流场的求解

### 3.6.1 积分形式的对流扩散方程及其离散

### 3.6.2 对流项的离散格式

### 3.6.3 扩散项和源项的离散

### 3.6.4 离散方程的最终形式

### 3.6.5 压力修正方程的导出

### 3.6.6 非结构化网格上SIMPLE算法的实施步骤

# 3.6 非结构化网格上流场的求解

## 3.6.1 积分形式的对流扩散方程及其离散

### 1. 非结构化网格上求解流场的三个选择

1) 节点位置选择：  
单元顶点；**单元中心**

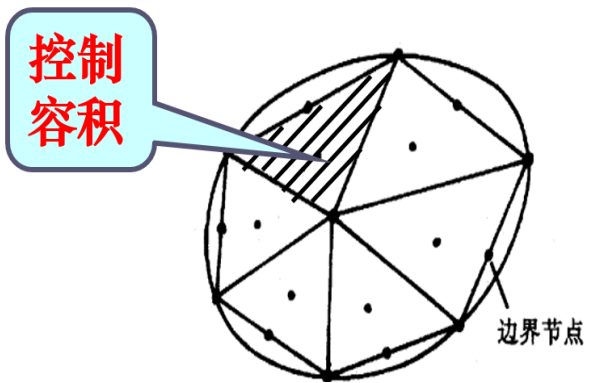
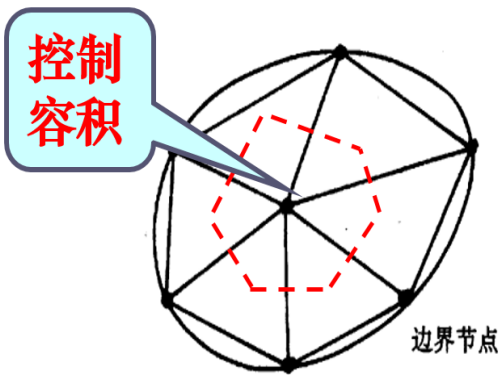

2) 速度与压力的相对位置：**交叉网格**；**同位网格**

3) 控制方程形式：**微分型**；**积分型**

采用积分形式将二阶导数降低到一阶导数,以减轻在非结构化网格上导数离散的难度。采用与结构化网格的类比的方法来导出非结构化网格上的表达式。

## 2. 控制方程 (积分形式)

对稳态问题，积分形式对流-扩散方程：

$$\int_A (\rho \vec{u} \phi - \Gamma_\phi \nabla \phi) \cdot d\vec{A} = \int_V S_\phi dV$$

通过界面流出的对流-扩散总通量等于其内部源项产生的量

将计算区域  $V$  用有限个三角形单元来离散，对其中任意一个三角形  $P_0$  有三个相邻单元：

$$\sum_{j=1}^3 \int_{A_j} (\rho \vec{u} \phi - \Gamma_\phi \nabla \phi) \cdot d\vec{A} = \int_V S_\phi dV$$

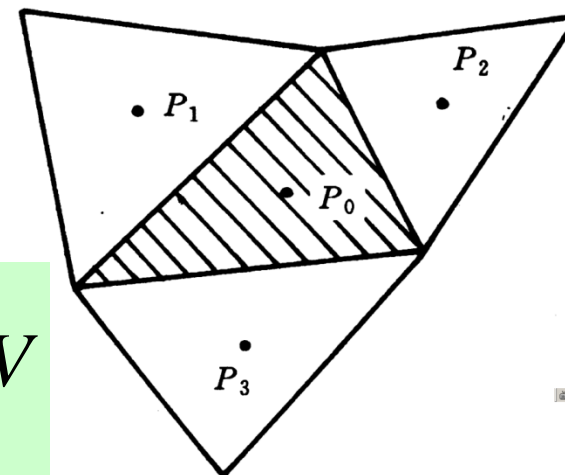

上式可简写为：

$$\sum_{j=1}^3 (C_j + D_j) = \int_{V_{P_0}} S_\phi dV$$

$C_j, D_j$  为界面上对流、扩散项的离散表达式。



### 3.6.2 对流项的离散格式

$$C_j = \int_{A_j} \rho \vec{u} \phi \cdot d\vec{A}_j \cong (\rho \vec{u} \phi)_j \cdot \vec{A}_j = (\rho \vec{u} \cdot \vec{A}_j) \phi_j = F_j \phi_j$$

$F_j$  为界面流量，流出为正，流入为负。引出两个问题：

**1. 如何用节点的值计算界面上的  $\phi_j$  ——格式问题；**

**(1) 一阶迎风**  $\left\{ \begin{array}{l} \phi_j = \phi_{P_0}, F_j > 0; \\ \phi_j = \phi_{P_j}, F_j < 0 \end{array} \right.$

**(2) 中心差分**

$\phi_j$  取为  $\phi_{P_j}$  与  $\phi_{P_0}$  之间的线性插。

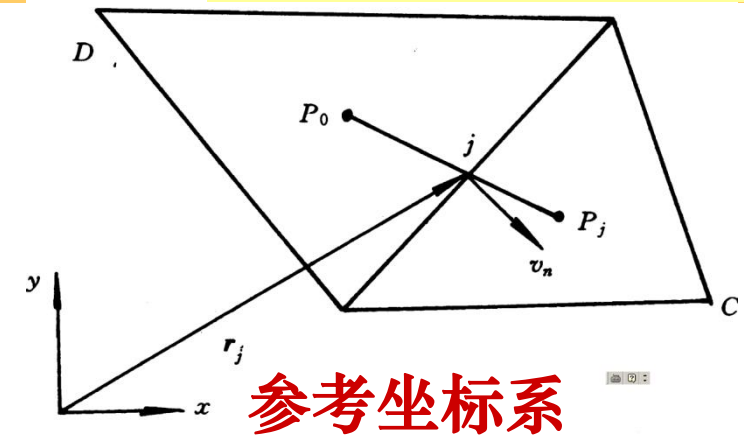

### (3) 二阶迎风

在直角坐标系中，当  $u_w > 0$  时有：

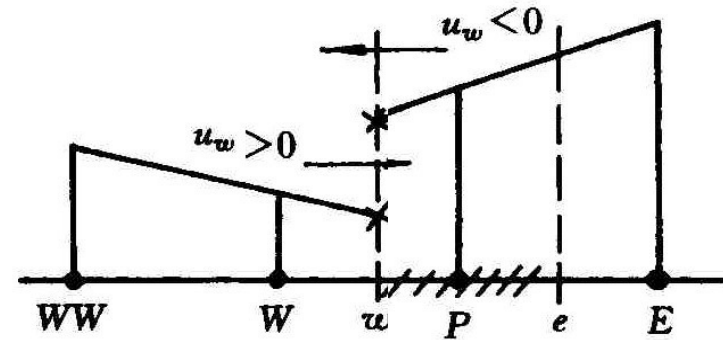

$$\phi_w = 1.5\phi_W - 0.5\phi_{WW} = \phi_W + 0.5(\phi_W - \phi_{WW}) =$$

$$\phi_W + \left( \frac{\phi_W - \phi_{WW}}{\Delta x} \right) \times 0.5\Delta x$$

w界面与W节点间的  
距离

平均梯度

仿照这个形式：

$$\phi_j = \phi_{P_0} + (\nabla \phi)_{P_0} \cdot (\vec{r}_j - \vec{r}_{P_0}), F_j > 0$$

$$\phi_j = \phi_{P_j} + (\nabla \phi)_{P_j} \cdot (\vec{r}_j - \vec{r}_{P_j}), F_j < 0$$

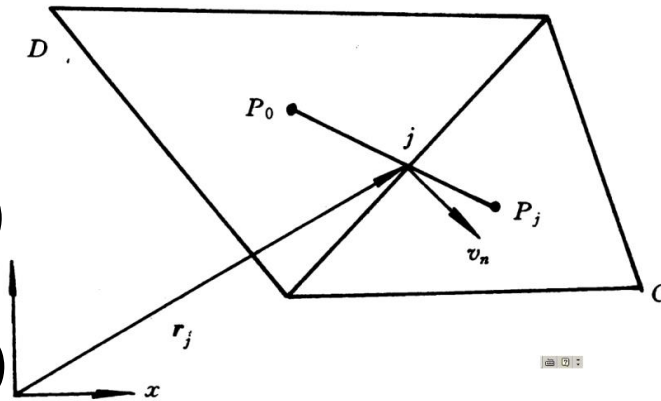



## (4)混合迎风

通过权因子  $\gamma$  将一阶与二阶迎风组合起来:

$$\phi_j = \begin{cases} \phi_{P_0} + \gamma (\nabla \phi)_{P_0} \cdot (\vec{r}_j - \vec{r}_{P_0}), & F_j > 0 \\ \phi_{P_j} + \gamma (\nabla \phi)_{P_j} \cdot (\vec{r}_j - \vec{r}_{P_j}), & F_j < 0 \end{cases} \quad (0 \leq \gamma \leq 1)$$

在非结构化网格，通过构筑一个虚拟的上游点  $U$  就可以采用第2章中的各种高阶格式:

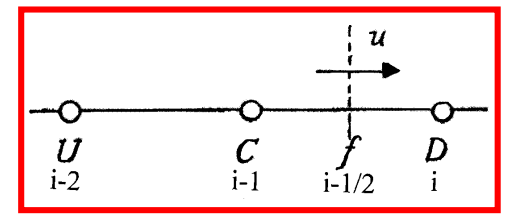

$$\phi_D - \phi_U = \nabla \phi_C \cdot \mathbf{d}_{UD}$$



$$\phi_U = \phi_D - 2 \nabla \phi_C \cdot \mathbf{d}_{CD}$$

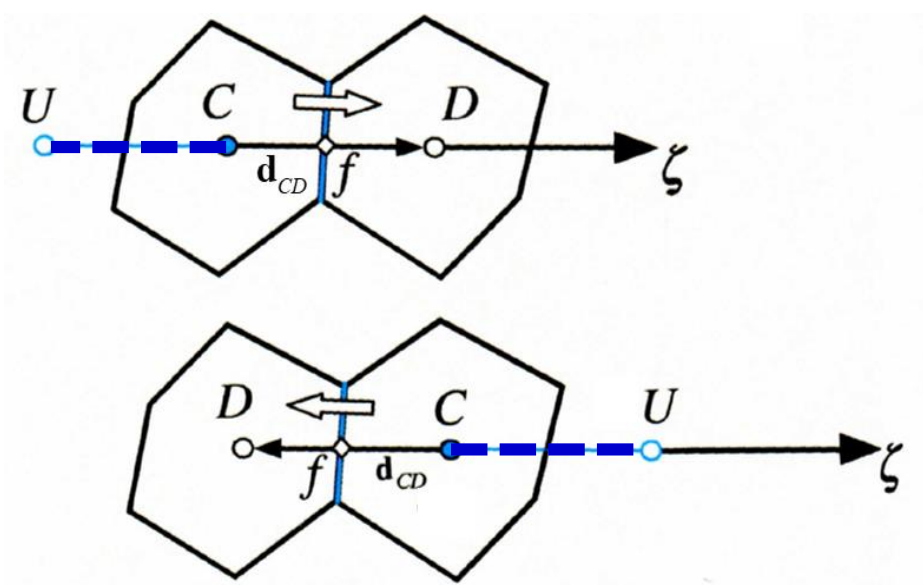

## (5) 单元中心 $(\nabla \phi)_{P_0}$ 的计算

要确定计算单元中的  $(\nabla \phi)_{P_0}$  就是要计算直角坐标系中的分量  $\frac{\partial \phi}{\partial x}, \frac{\partial \phi}{\partial y}$  的离散表达式。一种简单的方法如下：

(1) 将一阶导数的离散表达式看成是一阶导数在该单元中的平均值 (FVM的基本思想) :

$$\left(\frac{\partial \phi}{\partial x_i}\right)_{P_0} \cong \frac{\int_V \left(\frac{\partial \phi}{\partial x_i}\right) dV}{V_{P_0}}$$

(2D :  $i = 1, 2$ )

(2) 矢量  $\vec{\phi}$  的散度为

$$\left. \begin{array}{l} \text{其中 } \phi_x, \phi_y \text{ 为 } \vec{\phi} \text{ 在两轴上的分量。} \\ \text{如果 } \vec{\phi} = \phi \vec{i} + 0 \cdot \vec{j} \text{ 则} \\ \text{div}(\vec{\phi}) = \frac{\partial \phi}{\partial x} \end{array} \right\} \begin{array}{l} \text{div}(\vec{\phi}) = \frac{\partial \phi_x}{\partial x} + \frac{\partial \phi_y}{\partial y} \\ \text{div}(\vec{U}) = \frac{\partial u}{\partial x} + \frac{\partial v}{\partial y} \end{array}$$

因此  $\frac{\partial \phi}{\partial x}$  可以看成是矢量  $\vec{\phi} = \phi \vec{i}$  的散度；

(3) 利用上述结果和Gauss降维定律，导数计算式中的体积分可以进一步简化：

**Gauss降维定律**

$$\int_V \left( \frac{\partial \phi}{\partial x} \right) dV = \oint_A \underbrace{(\phi \vec{i}) \cdot d\vec{A}} = \oint_A \phi (\vec{i} \cdot \vec{n} dA) =$$

看成是  $\vec{\phi} \vec{i}$  的散度

矢量本身沿周界的积分

$$\sum_{j=1}^N \phi_j \underbrace{(\vec{i} \cdot \vec{n}_j A_j)} = \sum_{j=1}^N \phi_j A_j^x$$

$j$  界面在  $i$  方向即  $x$  方向的投影

$j$  是界面的编号

$A_j$  界面在  $i$  方向、即  $x$  方向的投影

即：
$$\int_V \left(\frac{\partial \phi}{\partial x}\right) dV = \sum_{j=1}^3 \phi_j A_j^x \quad (j=1,2,3) \quad \text{(x方向)}$$

类似地  $\frac{\partial \phi}{\partial y}$  可以看成是矢量  $\vec{\phi} = \phi \vec{j}$  的散度；

$$\int_V \left(\frac{\partial \phi}{\partial y}\right) dV = \sum_{j=1}^3 \phi_j A_j^y \quad (j=1,2,3) \quad \text{(y方向)}$$

梯度的两个分量为：

$$\left(\frac{\partial \phi}{\partial x_i}\right)_{P_0} \cong \frac{\int_V \left(\frac{\partial \phi}{\partial x_i}\right) dV}{V_{P_0}} = \frac{\sum_{j=1}^3 \phi_j A_j^i}{V_{P_0}} \quad (i=1,2)$$

## 2. 如何计算界面流量 $F_j$ ——同位网格特有的问题。

在非结构化的网格上一般都采用同位网格，即把所有的信息都存储于同一套节点上，界面没有流速，为保证不出现波形压力场，计算界面流速需要采取特殊方法。

# 目前文献中采用的一种确定界面流速的方如下：

参照结构化同位网格界面流速：

$$u_E = u_E - \left(\frac{A_P}{a_P}\right)_E (p_e - p_w)_E$$

$$u_e = u_e - \left(\frac{A_P}{a_P}\right)_e (p_E - p_P)$$

$$\left(\frac{A_P}{a_P}\right)_e = \left(\frac{A_P}{a_P}\right)_P \frac{(\delta x)_e^+}{(\delta x)_e} + \left(\frac{A_P}{a_P}\right)_E \frac{(\delta x)_e^-}{(\delta x)_e}$$

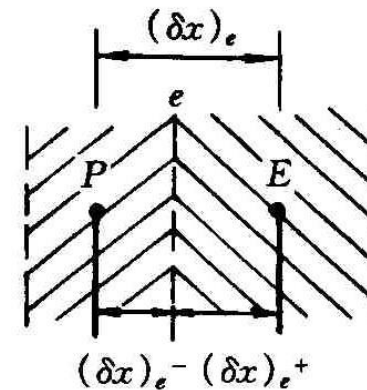
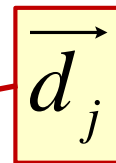
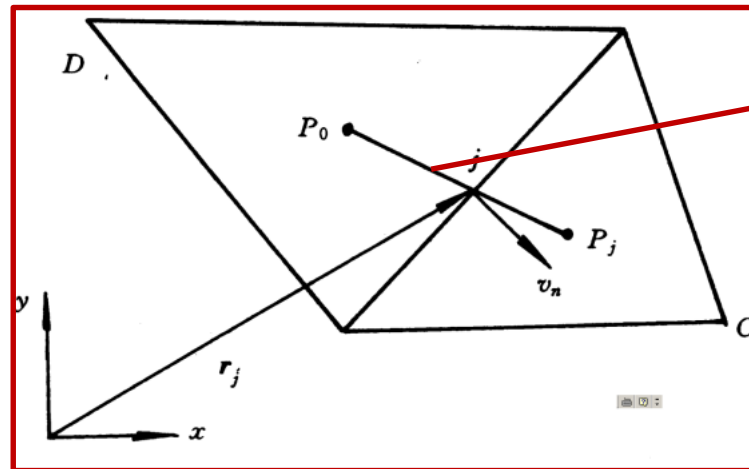
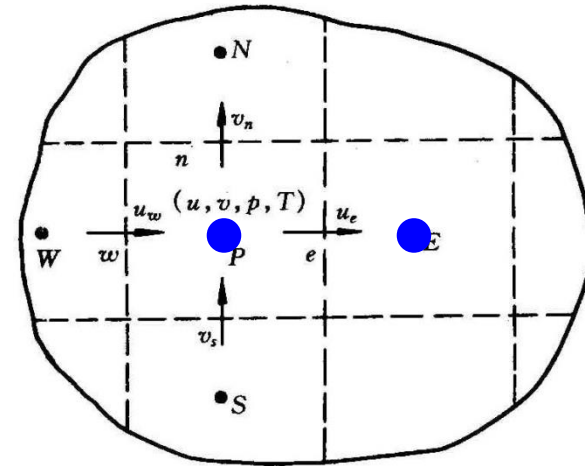

# 在 $A_j$ 方向上的一个速度小量(包含相邻2点压差)

$$\vec{u}_j = \vec{u}_{P_0} + K_j \left\{ \frac{1}{2} [(\nabla p)_{P_0} \cdot \frac{\vec{d}_j}{|d_j|} + (\nabla p)_{P_j} \cdot \frac{\vec{d}_j}{|d_j|}] - \frac{p_{P_j} - p_{P_0}}{|d_j|} \right\} \frac{\vec{A}_j}{|A_j|}$$

$u_{P_0}, u_{P_j}$   
之间的线性插值,  
无法采用  
 $u_{p_0j}$

压差项前的系数, 相当于:  
 $(\frac{A_P}{a_P})_e$

$d_j$  方向单位矢量

$P_0, P_j$  单元的平均压力梯度在  $d_j$  方向的投影, 其值与后者十分接近; 在结构化均分网格中将不显含相邻两点间的压差。

保证相邻两点间的压差出现在界面流速中的附加项, 以衰减波形压力场。

单位向量

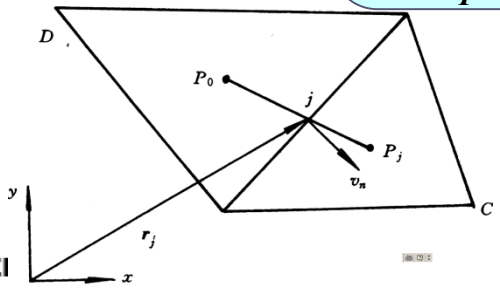

## 类似于结构化网格上同位网格的动量插值：

$$\left(\frac{A_P}{a_p}\right)_e = \left(\frac{A_P}{a_p}\right)_P \frac{(\delta x)_{e^+}}{(\delta x)_e} + \left(\frac{A_P}{a_p}\right)_E \frac{(\delta x)_{e^-}}{(\delta x)_e} \stackrel{\text{均分}}{=} \frac{1}{2} \left[ \left(\frac{A_P}{a_p}\right)_P + \left(\frac{A_P}{a_p}\right)_E \right]$$

在非结构化网格上该系数为

$$K_j = \frac{1}{2} \left[ \left(\frac{V}{a_0^u}\right)_{P_0} + \left(\frac{V}{a_0^u}\right)_{P_j} \right]$$

为抵消压力梯度中的距离，由面积改为体积。

在结构化网格上

$$u_e = u_e - \left(\frac{A_P}{a_p}\right)_e (p_E - p_P)$$

在非结构化网格上从量纲来看

$$\vec{u}_j = \vec{u}_{P_0j} + K_j \left\{ C - \frac{p_{P_j} - p_{P_0}}{|\vec{d}_j|} \right\} \frac{\vec{A}_j}{|\vec{A}_j|}$$

分母中多了一个长度

### 3.6.3 扩散项和源项的离散

在非结构化网格中扩散项的离散也较复杂。

$$D_j = \int (-\Gamma_\phi \nabla \phi) \cdot d\vec{A} = -\int \Gamma_\phi \nabla \phi \cdot d\vec{A}$$

其物理意义是通过界面  $j$  的扩散传递。将总传递分解为两部分：

- 沿着  $p_0 - p_j$  连线方向的扩散在界面  $j$  上的投影---称为常规分量；
- 沿着与  $p_0 - p_j$  连线的垂直方向的扩散在界面  $j$  上的投影---称为交叉分量。



# 1. 扩散项的常规分量的计算

$$D_j = -\int \Gamma_\phi \nabla \phi \cdot d\vec{A} = \underline{D_j^n} + \underline{D_j^c}$$

常规分量是指沿着  $P_0 - P_j$  连线的分矢量在面积矢量  $\vec{A}$  上的投影:

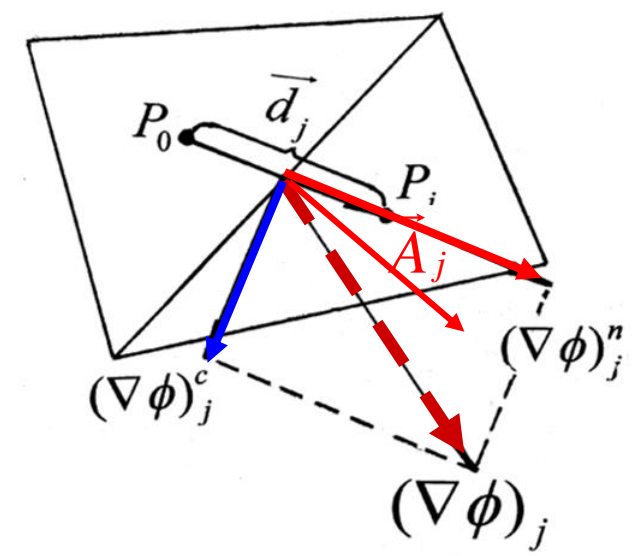

$$D_j^n = -\Gamma_\phi \left[ \frac{\phi_{P_j} - \phi_{P_0}}{|\vec{d}_j|} \frac{\vec{d}_j}{|\vec{d}_j|} \right] \cdot \vec{A}_j = -\Gamma_\phi (\phi_{P_j} - \phi_{P_0}) \frac{\vec{d}_j \cdot \vec{A}_j}{|\vec{d}_j|^2}$$

连线上变量的梯度

在面积  $A_j$  上的投影

# 2. 扩散项的交叉分量的计算

交叉分量是指沿着垂直于 $p_0 - p_j$ 连线方向的分矢量

在面积矢量  $\vec{A}_j$  上的投影，

$$D_j^c = -\Gamma_\phi \left\{ \underbrace{(\nabla \phi)_j}_{\text{总梯度与连线上矢量的矢量差}} - [(\nabla \phi)_j \cdot \underbrace{\frac{\vec{d}_j}{|\vec{d}_j|}}_{\text{总梯度在两节点连线方向的投影, 标量}}] \underbrace{\frac{\vec{d}_j}{|\vec{d}_j|}}_{\text{在连线上变量的梯度}} \right\} \cdot \vec{A}_j$$

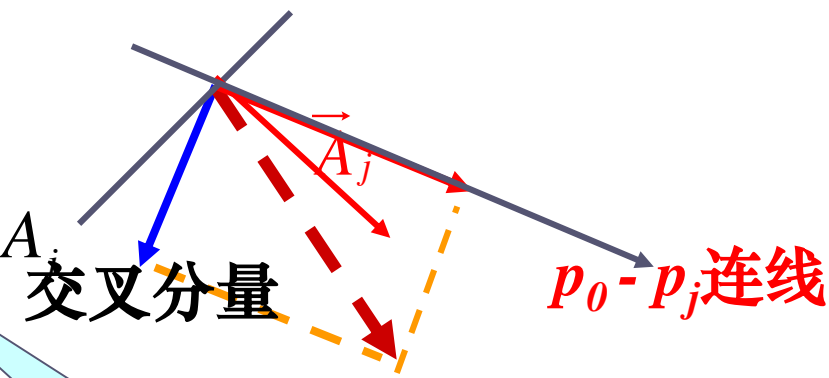

总梯度与连线上矢量的矢量差

总梯度在两节点连线方向的投影, 标量

在连线上变量的梯度

在面积  $A_j$  上的投影

### 3. 源项的离散

采用源项线性化的方法:  $S_\phi = S_C + S_P \phi_P$

$$\int_{V_{P_0}} S_\phi dV = S_C V_{P_0} + S_P \phi_{P_0} V_{P_0}$$

# 非结构化网格上对流扩散方程的离散过程汇总

1. 积分型控制方程

$$\int_A (\rho \vec{u} \phi - \Gamma_\phi \nabla \phi) \cdot d\vec{A} = \int_V S_\phi dV$$

$$\sum_{j=1}^3 \int_{A_j} (\rho \vec{u} \phi - \Gamma_\phi \nabla \phi) \cdot d\vec{A} = \int_V S_\phi dV$$

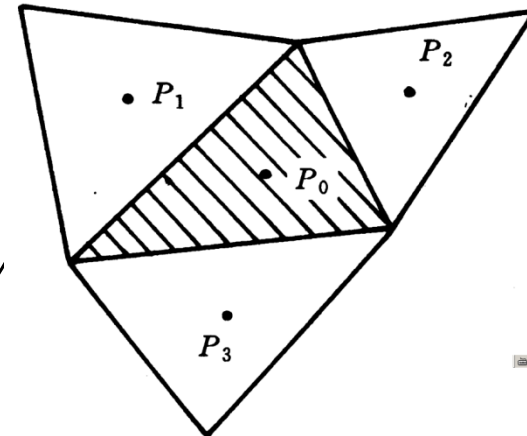

2. 方程的离散

$$\sum_{j=1}^3 (C_j + D_j) = \int_{V_{P_0}} S_\phi dV$$

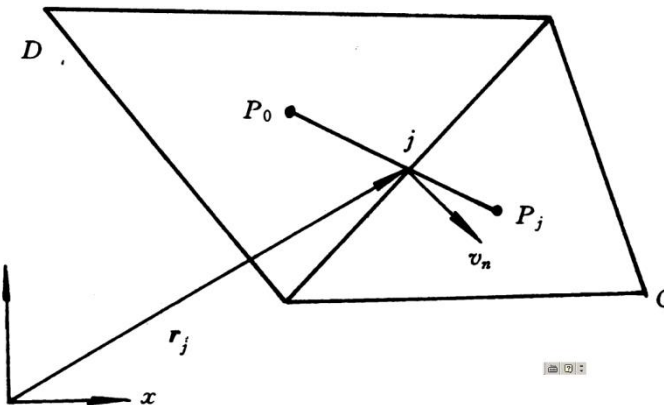

3. 对流通量

$$C_j = \int_{A_j} \rho \vec{u} \phi \cdot d\vec{A}_j = F_j \phi_j$$

3.1 界面插值

$$\phi_j = \begin{cases} \phi_{P_0} + \gamma (\nabla \phi)_{P_0} \cdot (\vec{r}_j - \vec{r}_{P_0}), & F_j > 0 \\ \phi_{P_j} + \gamma (\nabla \phi)_{P_j} \cdot (\vec{r}_j - \vec{r}_{P_j}), & F_j < 0 \end{cases} \quad (0 \leq \gamma \leq 1)$$

3.2 单元  $P_0$  的梯度

$$(\nabla \phi)_{P_0} = \left(\frac{\partial \phi}{\partial x}\right)_{P_0} \vec{i} + \left(\frac{\partial \phi}{\partial y}\right)_{P_0} \vec{j}$$

$$\left(\frac{\partial \phi}{\partial x_i}\right)_{P_0} \cong \frac{\int_V \left(\frac{\partial \phi}{\partial x_i}\right) dV}{V_{P_0}} = \frac{\sum_{j=1}^3 \phi_j A_j^i}{V_{P_0}} \quad (i = 1, 2)$$

3.3 单元  $P_0$  的界面流速

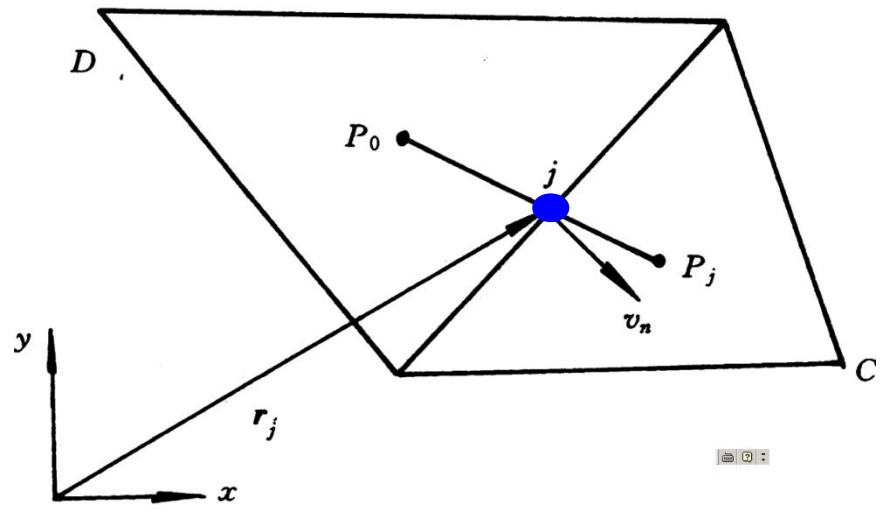

界面  
流速

在  $A_j$  方向上的一个速度小量(包含相邻2点压差)

$$\vec{u}_j = \vec{u}_{P_{0j}} + K_j \left\{ \frac{1}{2} \left[ (\nabla p)_{P_0} \cdot \frac{\vec{d}_j}{|d_j|} + (\nabla p)_{P_j} \cdot \frac{\vec{d}_j}{|d_j|} \right] - \frac{p_{P_j} - p_{P_0}}{|d_j|} \right\} \frac{\vec{A}_j}{|A_j|}$$

$u_{P_0}, u_{P_j}$   
之间的  
线性插  
值。

压差项  
前的系  
数，相  
当于：  
 $(\frac{A_P}{a_P})_e$

$d_j$   
方向  
单位  
矢量

$P_0, P_j$  单元的  
平均压力梯度  
在  $d_j$  方向的  
投影，其值与  
后者十分接近；  
在结构化均分  
网格中将不显  
含相邻两点间  
的压差。

保证相邻  
两点间的  
压差出现  
在界面流  
速中的附  
加项，以  
衰减波形  
压力场。

单位  
向量

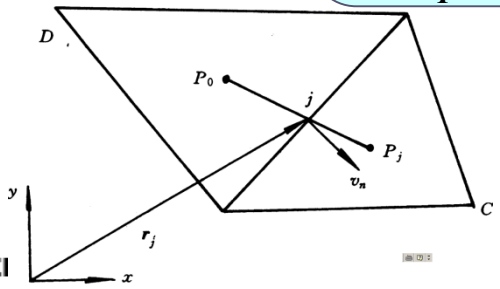

### 3.4 混合格式 $C_j$ 的紧凑表达方式（兼顾流速的正负两个方向）

$$C_j = F_j \phi_j = \max(F_j, 0) [\phi_{P_0} + \gamma (\nabla \phi)_{P_0} \cdot (\vec{r}_j - \vec{r}_{P_0})] \\ - \max(-F_j, 0) [\phi_{P_j} + \gamma (\nabla \phi)_{P_j} \cdot (\vec{r}_j - \vec{r}_{P_j})]$$

$$= [\max(F_j, 0) \phi_{P_0} - \max(-F_j, 0) \phi_{P_j}]$$

对流项的一阶迎风部分，进入求解项

$$+ \max(F_j, 0) \gamma (\nabla \phi)_{P_0} \cdot (\vec{r}_j - \vec{r}_{P_0}) - \max(-F_j, 0) \gamma (\nabla \phi)_{P_j} \cdot (\vec{r}_j - \vec{r}_{P_j})$$

对流项的其余部分，进入源项

### 4. 扩散通量

$$D_j = - \int \Gamma_\phi \nabla \phi \cdot d\vec{A} = D_j^n + D_j^c$$

4.1 扩散通量的常规分量 (连线的分量在 $A_j$ 上的投影)

$$D_j^n = -\Gamma_\phi (\phi_{P_j} - \phi_{P_0}) \frac{\vec{d}_j \cdot \vec{A}_j}{|\vec{d}_j|^2}$$

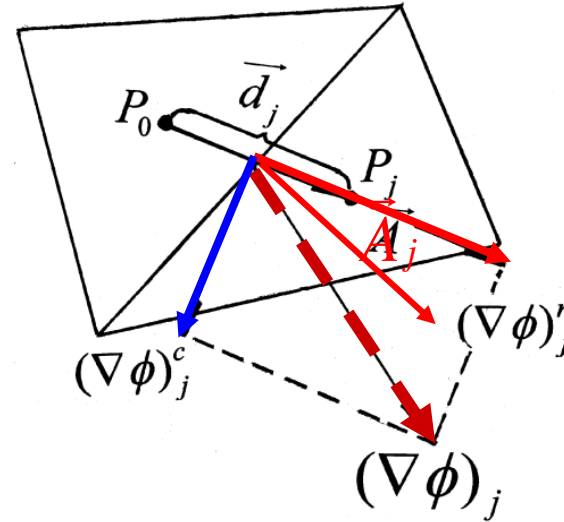

4.2 扩散通量的交叉分量 (与连线矢量垂直的分量在 $A_j$ 上的投影)

$$D_j^c = -\Gamma_\phi \left\{ (\nabla \phi)_j - [(\nabla \phi)_j \cdot \frac{\vec{d}_j}{|\vec{d}_j|}] \frac{\vec{d}_j}{|\vec{d}_j|} \right\} \cdot \vec{A}_j$$

5. 源项的离散

$$S_\phi = S_C + S_P \phi_P \int_{V_{P_0}} S_\phi dV = S_C V_{P_0} + S_P \phi_{P_0} V_{P_0}$$

## 3.6.4 离散方程的最终形式

$$\sum (C_j + D_j) = \int S_\phi dV$$

对流项离散的一阶迎风部分进入直接求解，其余部分进入源项（**延迟修正**）；

扩散项中的常规分量进入直接求解部分，交叉分量进入源项（**显式处理**）；

将含  $\phi_{P_0}$  项置于等号前，含  $\phi_{P_j}$  项置于等号后。  
 得：

$$\sum_{j=1}^3 \left\{ [\max(F_j, 0) + \frac{\Gamma_\phi}{|d_j|^2} (\vec{d}_j \cdot \vec{A}_j) - S_P V_{P_0}] \phi_{P_0} \right\} =$$

主节点系数



$$\sum_{j=1}^3 \left\{ \underbrace{[\max(-F_j, 0) + \frac{\Gamma_\phi}{|d_j|^2} (\vec{d}_j \cdot \vec{A}_j)]}_{\text{邻点系数}} \right\} \phi_{P_j} + S_C V_{P_0} +$$

源项常数部分

$$\sum_{j=1}^3 \gamma [(\nabla \phi)_{P_0} \max(F_j, 0) (\vec{r}_{P_0} - \vec{r}_j) + \sum_{j=1}^3 \gamma [(\nabla \phi)_{P_0} \max(-F_j, 0) (\vec{r}_j - \vec{r}_{P_j})]$$

对流部分的延迟修正

$$+ \sum_{j=1}^3 \Gamma_\phi [(\nabla \phi)_j - (\nabla \phi)_j \cdot \frac{\vec{d}_j}{|\vec{d}_j|} \frac{\vec{d}_j}{|\vec{d}_j|}] \cdot \vec{A}_j$$

交叉扩散部分显式处理

简写之：

$$a_{P_0} \phi_{P_0} = \sum_{j=1}^3 a_{P_j} \phi_{P_j} + b$$

$$a_{P_0} = \sum_{j=1}^3 a_{P_j} - S_P V_{P_0} \quad \text{要求质量守恒成立}$$

$$b = \text{源项常数部分} + \text{对流项延迟修正部分} + \text{交叉扩散部分}$$

### 3.6.5 压力修正方程的导出

类似于结构化网格上SIMPLE算法的压力修正方程的推导过程, 由界面流速的计算公式,

$$\vec{u}_j = \vec{u}_{P_{0j}} + K_j \left\{ \frac{1}{2} [(\nabla p)_{P_0} \cdot \frac{\vec{d}_j}{|\vec{d}_j|} + (\nabla p)_{P_j} \cdot \frac{\vec{d}_j}{|\vec{d}_j|}] - \frac{p_{P_j} - p_{P_0}}{|\vec{d}_j|} \right\} \frac{\vec{A}_j}{|\vec{A}_j|}$$

可得:

$$\vec{u}_j = -\frac{1}{2} \left[ \left( \frac{V}{a_0^u} \right)_{P_0} + \left( \frac{V}{a_0^u} \right)_{P_j} \right] \frac{p_{P_j} - p_{P_0}}{|\vec{d}_j|} \frac{\vec{A}_j}{|\vec{A}_j|} = -\left( \frac{V}{a_0^u} \right)_{P_j} \frac{p_{P_j} - p_{P_0}}{|\vec{d}_j|} \frac{\vec{A}_j}{|\vec{A}_j|}$$

速度修正值公式

要求  $(\vec{u}_j^* + \vec{u}_j')$  满足质量守恒, 可导出压力修正值方程

$$a_0^p p_{P_0}' = \sum_{j=1}^3 a_{P_j}^p p_{P_j}' + b^p \quad (\text{齐次Neumann边界条件})$$

$$a_j^p = \rho \left( \frac{V}{a_0^u} \right)_{P_j} \frac{|\vec{A}_j|}{|\vec{d}_j|}, \quad a_0^p = \sum_{j=1}^3 a_j^p, \quad b^p = \sum_{j=1}^3 F_j^*$$

### 3.6.6 非结构化网格上SIMPLE算法的实施步骤

1. 假定一个速度场  $\vec{u}^0$ ，计算系数与源项；
2. 假定一个压力场  $p^*$ ；
3. 求解动量方程，得出临时速度场  $\vec{u}^*$ ；
4. 据  $\vec{u}^*$  修正压力，获得修正分量  $p'$ ，要求与  $p'$  对应的  $\vec{u}'$  使  $(\vec{u}^* + \vec{u}')$  满足质量守恒，由此导出压力修正方程并求解之；
5. 获得  $p'$  后修正速度和压力；

节点压力 
$$p_{P_0} = p_{P_0}^* + \alpha_p p'_{P_0}$$

界面流速 
$$\vec{u}_j = \vec{u}_j^* - \left( \frac{V}{a_0^u} \right)_{P_j} \frac{p'_{P_j} - p'_{P_0}}{|d_j|} \frac{\vec{A}_j}{|A_j|}$$

节点流速 
$$\vec{u}_{P_0} = \vec{u}_{P_0}^* - \frac{V}{a_0^u} \nabla p'_{P_0}$$

6. 以  $\vec{u}$  以及  $p^* + \alpha_p p'$  开始下一层次的迭代计算。

非结构化网格上离散方程的求解难以应用结构化网格上行之有效的ADI-TDMA方法，一般采用G-S迭代法或者共轭梯度法。

## 3.6 SIMPLE系列算法向可压缩流的发展简介

### 3.6.1 引言—发展全速算法的必要性

### 3.6.2 目前构建流场全速算法的两种途径

### 3.6.3 基于压力算法的可压缩流与不可压缩流算法的主要区别

## 7.6.1 引言—发展全速算法的必要性

美国的X-51A飞行器在2010年5月26日进行的第一次飞行速度达到了5 Ma。

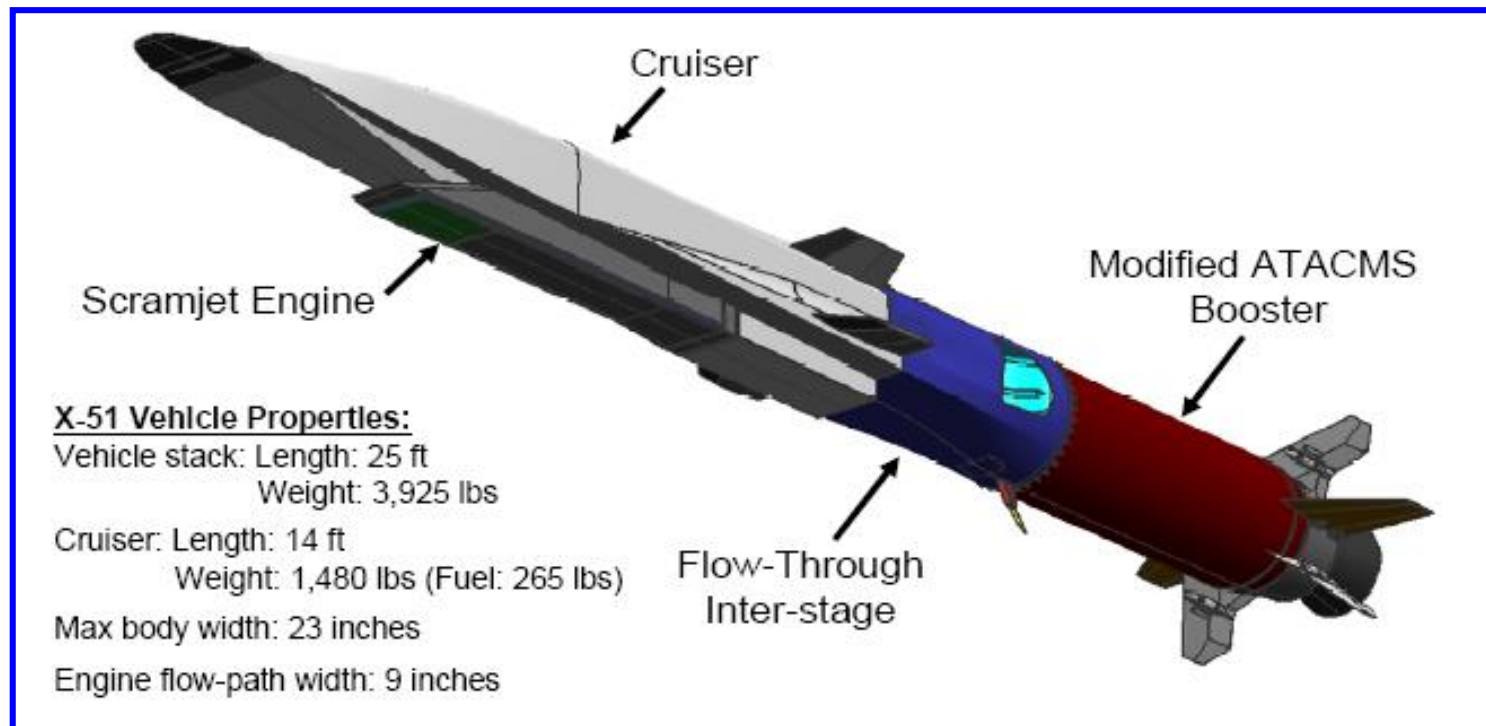

[http://www.cnhuu.com/junshi/chinajq/200804/junshi\\_195112.html](http://www.cnhuu.com/junshi/chinajq/200804/junshi_195112.html)

高超声速飞行器从地面起飞到达一定高度的飞行中，其四周气体的流速经历了两种变化；

(1) 从不可压缩流动到高Ma数流动；

(2) 从连续介质流动到稀薄气体薄流动。

由于特别适用于稀薄气体流动模拟的DSMC计算十分费时，因此只有在必须使用DSMC的局部地区才使用，其余地区仍然采用连续介质的数值方法。

因此发展一种能同时进行不可压缩与可压缩流场计算的所谓“全速”算法 (all speeds) 具有重要意义，引起了全世界的关注。



## 3.6.2 目前构建流场全速算法的两种途径

### 1. 基于密度方法-从可压缩流动延拓到不可压缩流动

以密度为基本变量的方法以 $(u, v, w, \rho)$ 为求解变量，最初是对欧拉方程求解提出的，后扩大到粘性流动，代数方程求解常采用直接解法。

基于密度的方法不适用用于马赫数很小的流动：在这些情况下密度的变化很小甚至不变，压力与密度之间的耦合变得很弱。

最近十余年随着航天航空事业的发展，将基于密度的方法向不可压缩推广引起了广泛关注。

## 2. 基于压力的方法-从不可压缩流动延拓到可压缩流动

无论流动马赫数为多少，压力的变化总是存在的。从这个角度看以压力作为基本变量的算法有望可以适用于整个马赫数范围，**但至今未获成功。**

从1989年出现将基于压力的方法推广到可压缩流动至今，已经提出了十余种基于压力的可压缩流动算法，但是计算的最高马赫数均小于10.

### 3.6.3 基于压力算法的可压缩流与不可压缩流算法的主要区别

- (1) 修正界面流量时除了考虑压力修正的作用引起的速度修正外还需考虑密度修正引起的变化；

(2) 压力修正方程从不可压缩的椭圆型方程变为双曲型方程

(3) 速度与压力边界条件的处理与不可压缩流不同。

本团队早期两篇博士论文（屈治国，2005；张宏伟，2006）  
喷管出口Ma分别达到3.4与6.7。

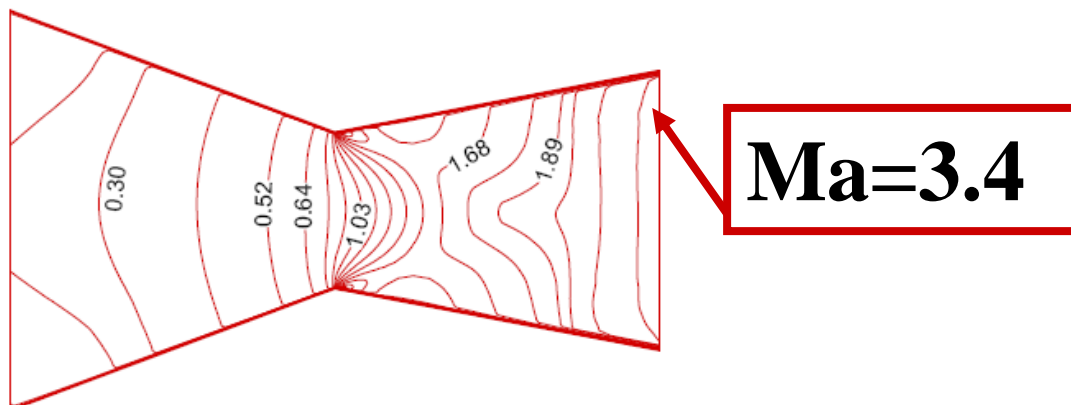

屈治国. 流动传热问题先进算法及其在强化空气对流传热应用中的研究. 西安交通大学, 2005.

张宏伟. 高压推力室流动与传热特性及液膜冷却的数值模拟研究. 西安交通大学, 2006.

近期，将IDEAL算法推广到喷管内跨音速可压缩流动，计算了采用三角形非结构化化网格离散的喷管内的流场与热场。

Wu T.Y, Zhang J F, Qu Z G, et al. Implementation of IDEAL algorithm based on Delaunay triangular mesh for 2D-compressible flows, Engineering Computations, 即将发表

在欧盟支持下Moukalled and Darwish将基于压力的算法计算到 $Ma=7$ ，且获得很高的计算精度。

1) 将规整变量公式 (NVF) 用于对流项的离散； 2) 将高分辨率格式用来进行密度插值。

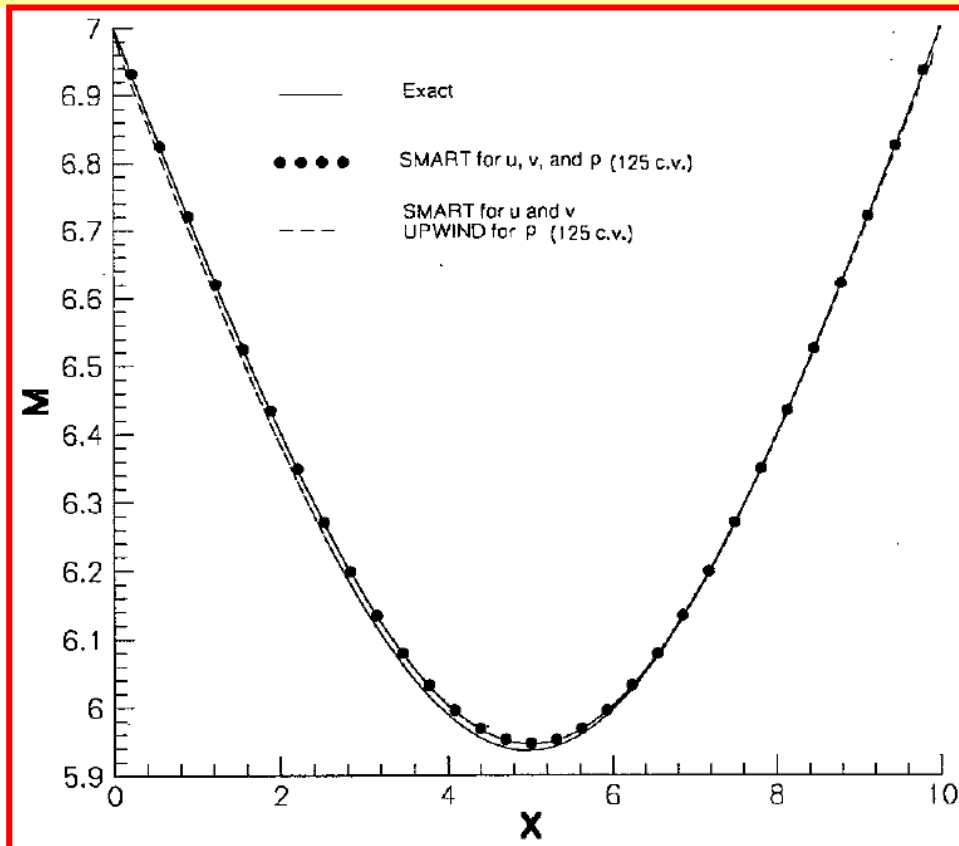

缩放喷管无粘流动沿程  
马赫数分布对比，进口  
马赫数为7

Moukalled F and Darwish M. A high-resolution pressure-based algorithm for fluid flow at all speeds. A report submitted to European Office of Aerospace Research and Development (EOARD), SPC-99-4003.

将基于压力的算法拓宽到高超声速下的高效计算仍然是一个难题，当前的进展不大。基于密度的算法可能是个基本选择，全速流场求解的统一算法问题仍然没有解决。

Karki KC, Patankar SV. Pressure based calculation procedure for viscous flows at all speeds in arbitrary configurations. AIAA J, 1989, 27(9):1167-1174

Shyy W, Chen M H, Sun C S. Pressure based multigrid algorithm for flow at all speeds. AIAA J, 1992, 30,2660-2669

Shyy W, Chen M H, Sun C S. Pressure based multigrid algorithm for flow at all speeds. AIAA J, 1992, 30,2660-2669

Demirdzic I, Leilek I, Peric M. A collocated finite volume method for predicting flows at all speeds. Int J Numer Methods Heat Fluids. 1993, 16: 1029 -1050

Date A W. Solutions of Navier-Stokes equations on non-staggered grids of all speeds. Numerical Heat Transfer, Part B,1998, 33:451-467

Wang, J.P., Zhang, J.F., Qu, Z.G., He, Y.L. and Tao, W.Q. Comparison of robustness and efficiency for SIMPLE and CLEAR algorithms with 13 high-resolution convection schemes in compressible flows, Numerical Heat Transfer Part B Fundamentals, 2014, 66 ( No. 2 ) : 133-16

## 文献阅读作业

- [1] Zeng M, Tao W Q. A comparison study of the convergence characteristics and robustness for four variants of SIMPLE family at fine grids. **Engineering Computations**, 2003, 20(3/4):320-341
- [2] Sun DL, Qu Z G, He Y L, Tao WQ. An efficient segregated algorithm for incompressible fluid flow and heat transfer problems-IDEAL (Inner doubly iterative efficient algorithm for linked equation) Part I:Mathematical formulation and solution. **Numerical Heat Transfer, Part B**, 2008,53(1);1-17
- [3] Jin-Ping Wang, Jian-Fei Zhang, Zhi-Guo Qu & Wen-Quan Tao. Adaptive inner iteration processes in pressure based method for viscous compressible flows, **Numerical Heat Transfer, Part B**, 2018, 74(3): 603–622
- [4] Wei You, Zeng-Yao Li & Wen-Quan Tao. A general self-adaptive under-relaxation strategy for fast and robust convergence of iterative calculation of incompressible flow. **Numerical Heat Transfer, Part B**, 2020, 77(4): 299–310
- [5] Peric M, Kessler R, Scheurer G., Comparison of finite volume numerical methods with staggered and collocated grids, **Computers & Fluids**, 1988,16:389-401

本组网页地址：<http://nht.xjtu.edu.cn>  
其中虚拟仿真实验教学中心一栏的资源下载中有：  
**2D-IDEAL**算法程序；  
**Delauney** 非结构化网格生成及流场的求解程序  
欢迎访问、下载！



**同舟共济  
渡彼岸！**

**People in the  
same boat help  
each other to  
cross to the other  
bank, where....**