

Numerical Heat Transfer

(数值传热学)

Chapter 4 Numerical Solution of Diffusion Equation and its Applications(1)



Instructor Tao, Wen-Quan

CFD-NHT-EHT Center

Key Laboratory of Thermo-Fluid Science & Engineering

Xi'an Jiaotong University

Xi'an, 2017-October.-09

数值传热学

第四章 扩散方程的数值解及其应用(1)



主讲 陶文铨

西安交通大学能源与动力工程学院
热流科学与工程教育部重点实验室
2017年10月9日, 西安

Contents

4.1 1-D Heat Conduction Equation

4.2 Fully Implicit Scheme of Multi-dimensional Heat Conduction Equation

4.3 Treatments of Source Term and B.C.

4.4 TDMA & ADI Methods for Solving ABEs

4.5 Fully Developed HT in Circular Tubes

4.6 Fully Developed HT in Rectangle Ducts

4.1 1-D Heat Conduction Equation

4.1.1 General equation of 1-D steady heat conduction

4.1.2 Discretization of G.G.E. by CV method

4.1.3 Determination of interface thermal conductivity

4.1.4 Discretization of 1-D unsteady heat conduction equation

4.1.5 Mathematical stability can't guarantee solution physically meaningful (有意义的)

4.1 1-D Heat Conduction Equation

4.1.1 G.E. of 1-D steady heat conduction

1. Two ways of coding for solving engineering problems

Specific code(专用程序): FLOWTHERN, POLYFLOW...Having some generality within its application range.

General code(通用程序): HT, FF, Combustion, MT, Reaction, etc.; PHOENICS, FLUENT, STAR-CD, CFX....

Different codes tempt to have some generality.

Generality includes: Coordinates; G.E.; B.C. treatment; Source term treatment; Geometry.....

2. General governing equations of 1-D steady heat conduction problem

$$\frac{1}{A(x)} \frac{d}{dx} \left[\lambda A(x) \frac{dT}{dx} \right] + S = 0$$

x ----Independent space variable (独立空间变量),
normal to cross section

$A(x)$ ----Area factor, normal to heat conduction
direction

λ ----Thermal conductivity

S ---- Source term, may be a function of both x and T .

$$\frac{1}{A(x)} \frac{d}{dx} \left[\lambda A(x) \frac{dT}{dx} \right] + S = 0$$

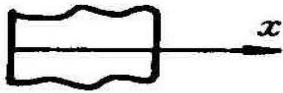
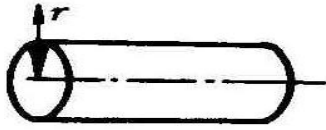
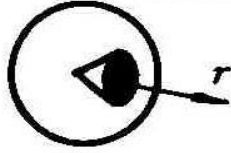
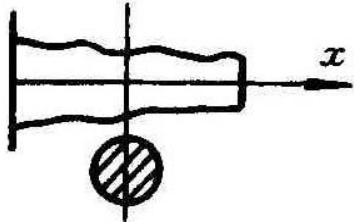
| Mode | Coordinate | Indep. variable | Area factor | Illustration (图示) |
|------|------------------------|-------------------------------|---------------------------------------|---|
| 1 | Cartesian | x | 1(unit) |  |
| 2 | Cylindrical | r | r (arc 弧度 area) |  |
| 3 | Spherical | r | r ² (spherical surface) |  |
| 4 | Variable cross section | x Perpendicular to section | A(x), ⊥ Heat conduction direction |  |

4.1.2 Discretization of G.G.Eq. by CVM

Multiplying two sides by $A(x)$

$$\frac{1}{A(x)} \frac{d}{dx} \left[\lambda A(x) \frac{dT}{dx} \right] + S = 0 \quad \longrightarrow \quad \frac{d}{dx} \left[\lambda A(x) \frac{dT}{dx} \right] + S \cdot A(x) = 0$$

Linearizing (线性化) source term : $S = S_C + S_P T_P$

S_C and S_P are constant in the CV.

Adopting piecewise linear profile:

Integrating over control volume P yielding (得)

$$\left[\lambda A(x) \frac{dT}{dx} \right]_e - \left[\lambda A(x) \frac{dT}{dx} \right]_w + \int (S_C + S_P T_P) A(x) dx = 0$$

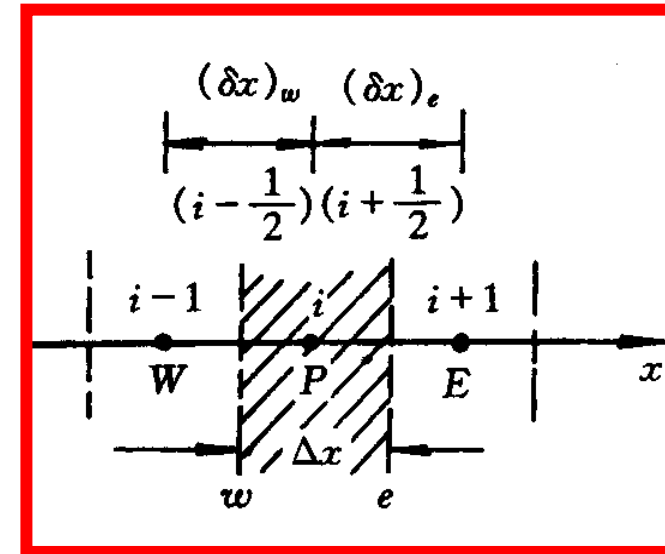

$$\lambda_e A_e(x) \frac{T_E - T_P}{(\delta x)_e} - \lambda_w A_w(x) \frac{T_P - T_W}{(\delta x)_w} + (S_C + S_P T_P) \cdot A_P(x) \cdot \Delta x = 0$$

Moving terms with T_P to left side while those with T_E, T_W to right side

$$T_P \left[\frac{A_e(x) \lambda_e}{(\delta x)_e} + \frac{A_w(x) \lambda_w}{(\delta x)_w} - S_P A_P(x) \Delta x \right] = T_E \left[\frac{A_e(x) \lambda_e}{(\delta x)_e} \right] + T_W \left[\frac{A_w(x) \lambda_w}{(\delta x)_w} \right] + S_C A_P(x) \Delta x$$

We adopt following well-accepted form for discretized eqs.:

$$a_P T_P = a_E T_E + a_W T_W + b$$

$$a_E = \frac{\lambda_e A(x)_e}{(\delta x)_e}, \quad a_W = \frac{\lambda_w A(x)_w}{(\delta x)_w}, \quad b = S_C A_P(x) \Delta x = S_C \Delta V$$

$$a_P = a_E + a_W - S_P \Delta V$$

Physical meaning of coefficients a_E, a_W

$$a_E = \frac{1}{(\delta x)_e / [\lambda_e A(x)_e]} = \frac{1}{\text{Thermal resistance between P and E}}$$

It represents the effect of point E on point P, and is also called influencing coefficient (影响系数).

4.1.3 Determination of interface thermal conductivity

1. Arithmetic mean (算术平均法)

$$\lambda_e = \lambda_P \frac{(\delta x)_{e^+}}{(\delta x)_e} + \lambda_E \frac{(\delta x)_{e^-}}{(\delta x)_e}$$

Uniform grid



$$\lambda_e = \frac{\lambda_P + \lambda_E}{2}$$

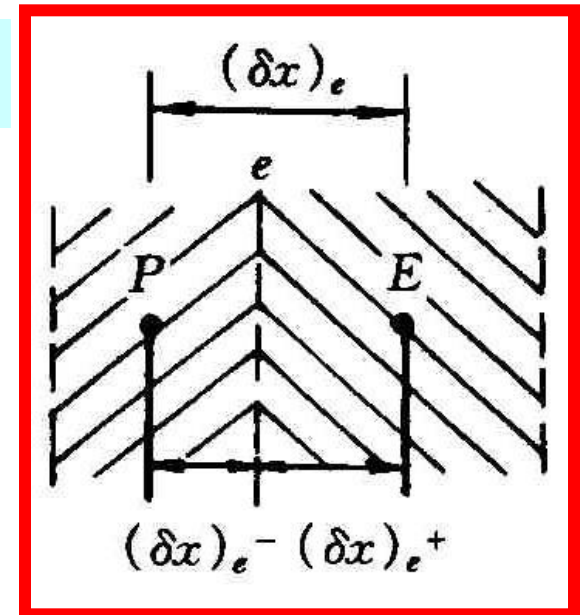

2. Harmonic mean (调和平均法)

Assuming that conductivities of P, E are different, according to the continuum requirement of heat flux (热流密度的连续性要求) at interface: a

$$\frac{T_E - T_e}{(\delta x)_{e^+}} = \frac{T_e - T_P}{(\delta x)_{e^-}} \rightarrow \frac{T_E - T_P}{(\delta x)_{e^+} + (\delta x)_{e^-}}$$

Left side

Right side

Algebraic operation rule

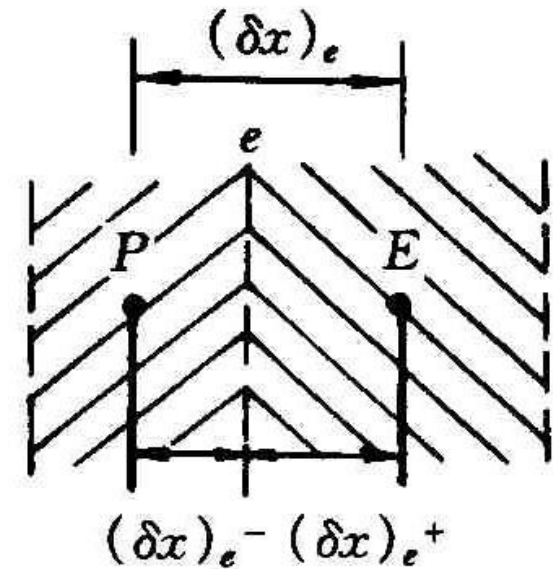

$$\frac{T_E - T_P}{(\delta x)_{e^+} + (\delta x)_{e^-}} = \frac{T_E - T_P}{(\delta x)_e}$$

Interface conductivity

$$\frac{(\delta x)_e}{\lambda_e} = \frac{(\delta x)_{e^+}}{\lambda_E} + \frac{(\delta x)_{e^-}}{\lambda_P}$$

Harmonic mean

For uniform grid:

$$\lambda_e = \frac{2\lambda_P\lambda_E}{\lambda_P + \lambda_E}$$

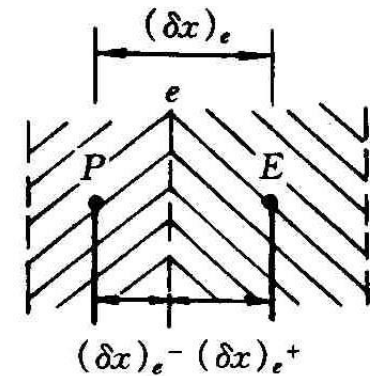

3. Comparison of two methods

If $\lambda_P \gg \lambda_E$ major resistance is at E-side, while A.M.:

$$\lambda_e = \frac{\lambda_P + \lambda_E}{2} \xrightarrow{\lambda_P \gg \lambda_E} \lambda_e \cong \frac{\lambda_P}{2} \xrightarrow{\text{Resis.}} \frac{(\delta x)_e}{\frac{\lambda_P}{2}}$$

From harmonic mean:

$$\lambda_e = \frac{2\lambda_E\lambda_P}{\lambda_E + \lambda_P} \xrightarrow{\lambda_P \gg \lambda_E} \lambda_e \cong 2\lambda_E \xrightarrow{\text{Resis.}} \frac{(\delta x)_e}{2\lambda_E} \xrightarrow{\text{Uniform}} \frac{(\delta x)_e}{\lambda_E} \xrightarrow{\text{Reasonable!}}$$

Harmonic mean has been widely accepted.

4.1.4 Discretization of 1-D transient heat conduction equation

1. Governing eq.

$$\rho c \frac{\partial T}{\partial t} = \frac{1}{A(x)} \frac{d}{dx} \left[\lambda A(x) \frac{dT}{dx} \right] + S$$

2. Integration over CV Multiplying by $A(x)$, assuming

ρc is independent on time, integrating over CV P within time step Δt

$$(\rho c)_P A_P(x) \Delta x (T_P^{n+1} - T_P^n) = \int_t^{t+\Delta t} \left[\frac{\lambda_e A_e(x) (T_E - T_P)}{(\delta x)_e} - \frac{\lambda_w A_w(x) (T_P - T_W)}{(\delta x)_w} \right] dt$$

Stepwise in space

Needs to select time profile

$$+ \Delta x A_P(x) \int_t^{t+\Delta t} (S_C + S_P T_P) dt$$

3. Results with a general time profile

$$\int_t^{t+\Delta t} T dt = [fT^{t+\Delta t} + (1-f)T^t] \Delta t, \quad 0 \leq f \leq 1$$

Substituting this profile, integrating, yields:

$$a_P T_P = a_E [fT_E + (1-f)T_E^0] + a_W [fT_W + (1-f)T_W^0] +$$

$$T_P^0 [a_P^0 - (1-f)a_E - (1-f)a_W + (1-f)S_P A_P(x) \Delta x] + S_C A_P(x) \Delta x$$

$$a_E = \frac{\lambda_e A_e(x)}{(\delta x)_e} = \frac{A_e(x)}{\frac{(\delta x)_{e^+}}{\lambda_E} + \frac{(\delta x)_{e^-}}{\lambda_P}}$$

$$a_W = \frac{\lambda_w A_w(x)}{(\delta x)_w} = \frac{A_w(x)}{\frac{(\delta x)_{w^+}}{\lambda_P} + \frac{(\delta x)_{w^-}}{\lambda_W}}$$

$$a_P = fa_E + fa_W + a_P^0 - fS_P A_P(x) \Delta x$$

$$a_P^0 = \frac{\rho c A_P(x) \Delta x}{\Delta t} = \frac{\rho c \Delta V}{\Delta t}$$

Thermal inertia (热惯性)

4. Stability analysis

From von Neumann analysis method it can be shown:

$0.5 \leq f \leq 1$, Absolutely stable;

$0 \leq f < 0.5$, Conditionally stable:

$$\frac{a\Delta t}{\Delta x^2} \leq \frac{1}{2(1-f)}$$

5. Three forms of time level for discretized diffus. term

(1) Explicit(显), $f = 0$;
$$\frac{T_P - T_P^0}{\Delta t} = a \left(\frac{T_E^0 - 2T_P^0 + T_W^0}{\Delta x^2} \right)$$

(2) Fully implicit(全隐) $f = 1$;
$$\frac{T_P - T_P^0}{\Delta t} = a \left(\frac{T_E - 2T_P + T_W}{\Delta x^2} \right)$$

(3) C-N scheme, $f = 0.5$

$$\frac{T_P - T_P^0}{\Delta t} = \frac{a}{2} \left(\frac{T_E - 2T_P + T_W}{\Delta x^2} + \frac{T_E^0 - 2T_P^0 + T_W^0}{\Delta x^2} \right)$$

**No subscript for
($t + \Delta t$) time level**

4.1.5 Mathematical stability can't guarantee solution physically meaningful

Illustrated by an example.

[Known] 1-D transient HC without source term, uniform initial field. Two surfaces were suddenly cooled down to zero.

[Find] Variation of inner point temp.

[Solution] Discretized by Practice A
Adopting three grids: W, P, and E.

Physically following variation trend can be expected!

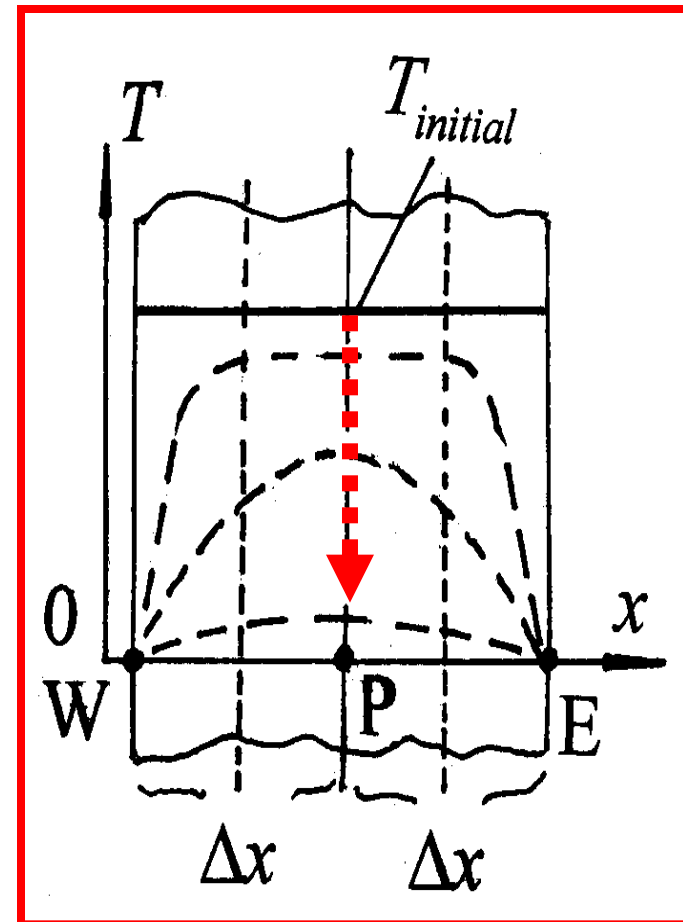

Analyzing for the 2nd time level:

$$T_E = T_E^0 = T_W = T_W^0 = 0 ; S_C = 0, S_P = 0 \quad \text{Substituting:}$$

$$a_P T_P = a_E [f T_E + (1-f) T_E^0] + a_W [f T_W + (1-f) T_W^0] + T_P^0 [a_P^0 - (1-f)a_E - (1-f)a_W + (1-f)S_P A_P(x)\Delta x] + S_C A_P(x)\Delta x$$

Yields $a_P T_P = T_P^0 [a_P^0 - (1-f)a_E - (1-f)a_W]$

i.e.:
$$\frac{T_P}{T_P^0} = \frac{a_P^0 - (1-f)(a_W + a_E)}{a_P} = \frac{a_P^0 - (1-f)(a_W + a_E)}{a_P^0 + f(a_W + a_E)}$$

$$a_E = a_W = \frac{\lambda \bullet 1}{\Delta x}, a_P^0 = \frac{\rho c_p \Delta x}{\Delta t}, \frac{a_E}{a_P^0} = \frac{\lambda / \Delta x}{\rho c_p \Delta x / \Delta t} = \left(\frac{\lambda}{\rho c_p}\right) \frac{\Delta t}{\Delta x^2} = \frac{a \Delta t}{\Delta x^2}$$

Finally:
$$\frac{T_P}{T_P^0} = \frac{1 - 2(1-f)\left(\frac{a \Delta t}{\Delta x^2}\right)}{1 + 2f\left(\frac{a \Delta t}{\Delta x^2}\right)}$$

$$\frac{T_P}{T_P^0} = \frac{1 - 2(1-f)Fo_\Delta}{1 + 2fFo_\Delta}$$

Physically it is required :

$$\frac{T_P}{T_P^0} > 0$$

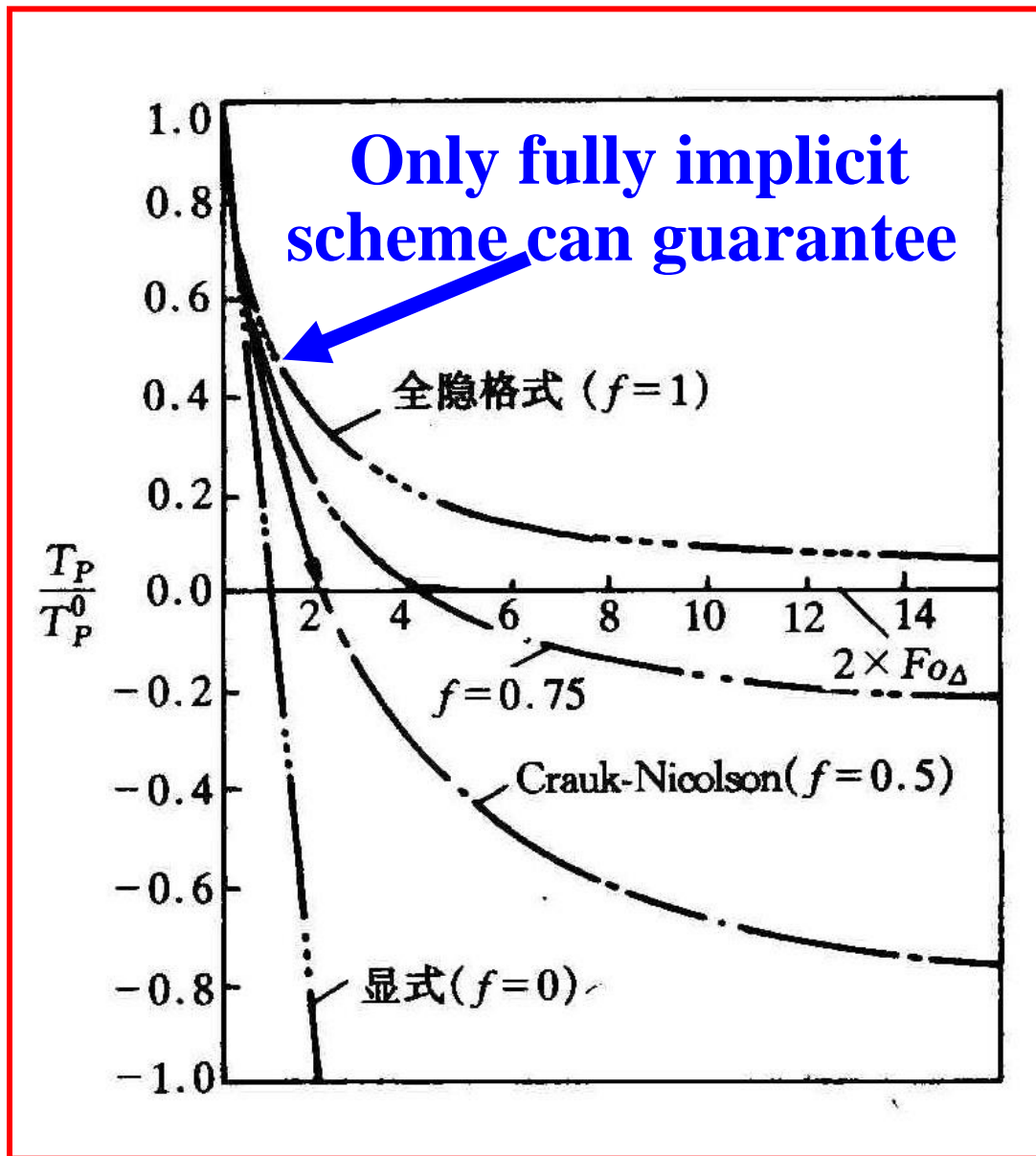
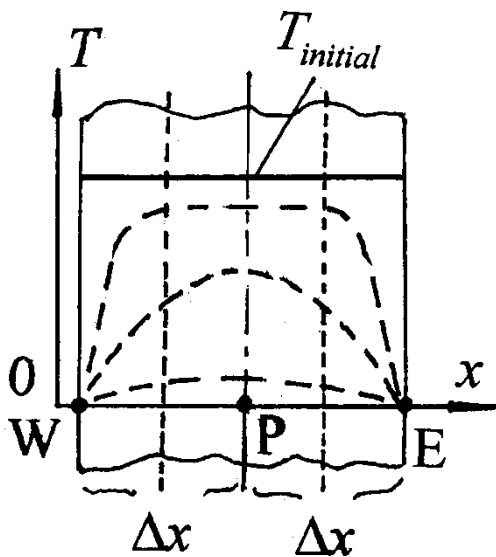

Only when $f = 1$ (fully imp.) can guarantee

This can be obtained from physical analysis!

The discretized form of transient HC is:

$$a_P T_P = a_E T_E + a_W T_W + a_t T_P^0 + b$$

where all coefficients must by ≥ 0

$$a_t = a_P^0 - (1-f)a_E - (1-f)a_W \geq 0$$

$$1 - (1-f)(a_E + a_W) / a_P^0 \geq 0$$

$$\frac{a_E}{a_P^0} = \frac{a\Delta t}{\Delta x^2} = Fo_{\Delta} \quad Fo_{\Delta} \leq \frac{1}{2(1-f)}$$

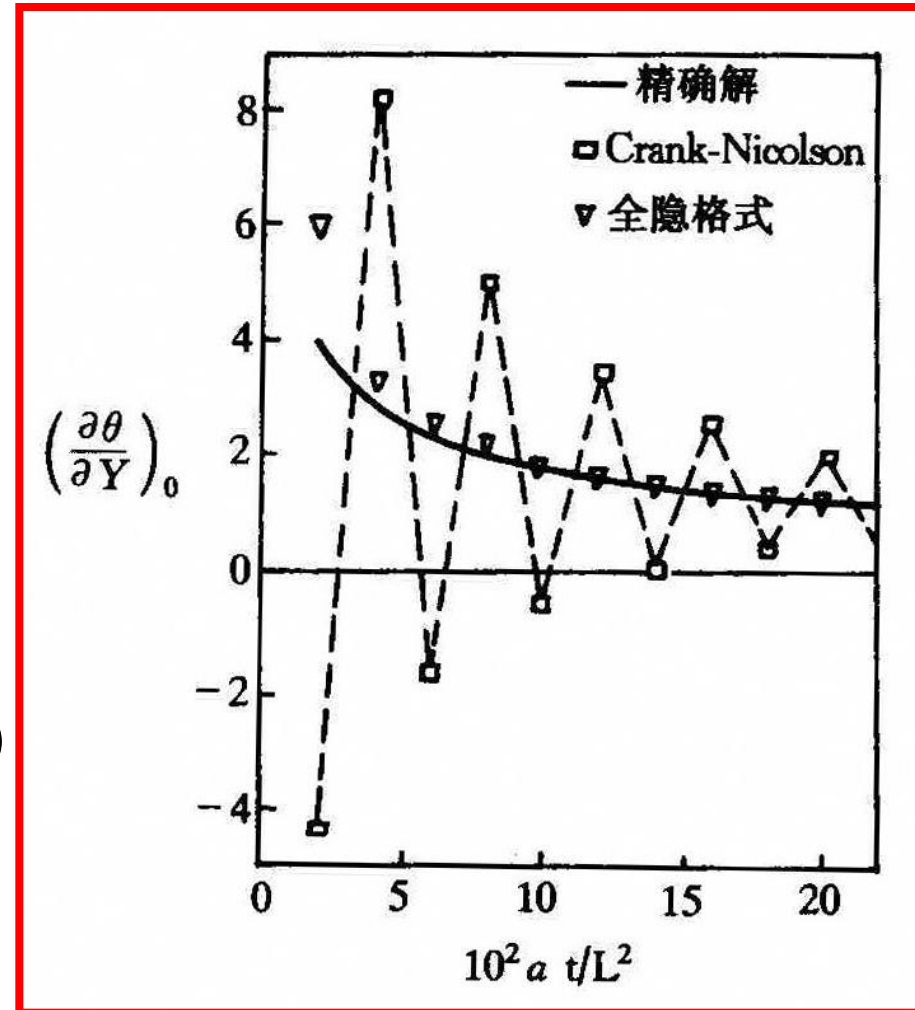

Conclusion: mathematical stability can't guarantee solution physically meaningful!

4.2 Fully Implicit Scheme of Multi-dimensional Heat Conduction Equation

4.2.1 Fully implicit scheme in three coordinates

4.2.2 Comparison between coefficients

4.2.3 Uniform expression of discretized form for three coordinates

4.2 Fully Implicit Scheme of Multi-dimensional Heat Conduction Equation

4.2.1 Fully implicit scheme in three coordinates

1. Cartesian coordinates

(1) Governing eq.

$$\rho c \frac{\partial T}{\partial t} = \frac{\partial}{\partial x} \left(\lambda \frac{\partial T}{\partial x} \right) + \frac{\partial}{\partial y} \left(\lambda \frac{\partial T}{\partial y} \right) + S$$

(2) CV integration

Space profiles are the same as 1-D problem.

Fully implicit for time

Heat flux is uniform at interface.

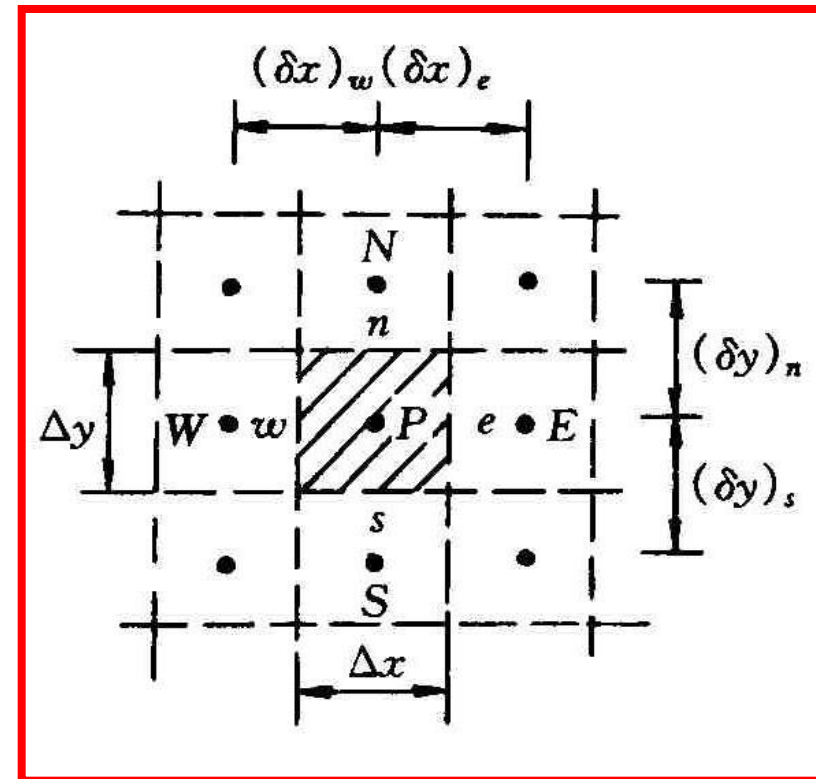

Integration of transient term =

$$\int_s^n \int_w^e \int_t^{t+\Delta t} \rho c \frac{\partial T}{\partial t} dx dy dt \xrightarrow{\text{stepwise}} (\rho c)_P (T_P - T_P^0) \Delta x \Delta y$$

$$\text{Diffusion term (1)} = \int_s^n \int_w^e \int_t^{t+\Delta t} \frac{\partial}{\partial x} \left(\lambda \frac{\partial T}{\partial x} \right) dx dy dt =$$

Space linear wise
Heat flux uniform,
Time fully implicit

$$\int_s^n \int_t^{t+\Delta t} \left[\left(\lambda \frac{\partial T}{\partial x} \right)_e - \left(\lambda \frac{\partial T}{\partial x} \right)_w \right] dy dt$$

$$= \left(\lambda_e \frac{T_E - T_P}{(\delta x)_e} - \lambda_w \frac{T_P - T_W}{(\delta x)_w} \right) \Delta y \Delta t$$

**No subscript for
(n+1) time level**

Diffusion term (2) =
$$\int_s^n \int_w^e \int_t^{t+\Delta t} \frac{\partial}{\partial y} \left(\lambda \frac{\partial T}{\partial y} \right) dx dy dt =$$

$$\int_w^e \int_t^{t+\Delta t} \left[\left(\lambda \frac{\partial T}{\partial y} \right)_n - \left(\lambda \frac{\partial T}{\partial y} \right)_s \right] dx dt$$

Space linear wise
Heat flux uniform,
Time fully implicit

$$= \left(\lambda_n \frac{T_N - T_P}{(\delta y)_n} - \lambda_s \frac{T_P - T_S}{(\delta y)_s} \right) \Delta x \Delta t$$

Source term =
$$\int_w^e \int_s^n \int_t^{t+\Delta t} S dx dy dt \xrightarrow{\text{Linealization}} (S_C + S_P T_P) \Delta x \Delta y \Delta t$$

Fully implicit

Substituting and rearranging:

$$a_P T_P = a_E T_E + a_W T_W + a_N T_N + a_S T_S + b$$

$$a_E = \frac{\Delta y}{(\delta x)_e / \lambda_e}, a_W = \frac{\Delta y}{(\delta x)_w / \lambda_w}, a_N = \frac{\Delta x}{(\delta y)_n / \lambda_n}, a_S = \frac{\Delta x}{(\delta y)_s / \lambda_s}$$

$$a_P = a_E + a_W + a_N + a_S + a_P^0 - S_P \Delta x \Delta y$$

$$a_P^0 = \frac{\rho c \Delta V}{\Delta t}, b = S_C \Delta V + a_P^0 T_P^0$$

Physical meaning of coefficients:
reciprocal (倒数) of thermal
resistance, or heat conductance
(热导) between neighboring grids.

$$a_E = \frac{\Delta y}{(\delta x)_e / \lambda_e} = \frac{\lambda_e \Delta y}{(\delta x)_e}$$

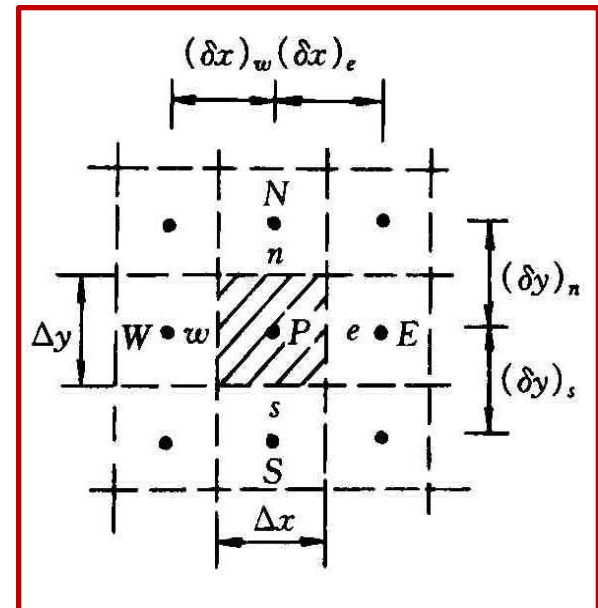

2. Cylindrical symmetry

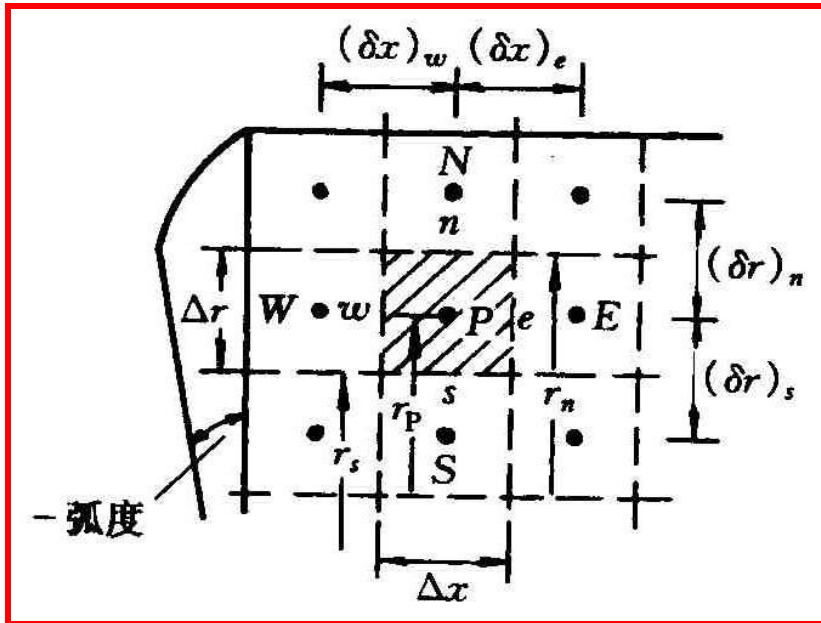

3. Polar coordinates

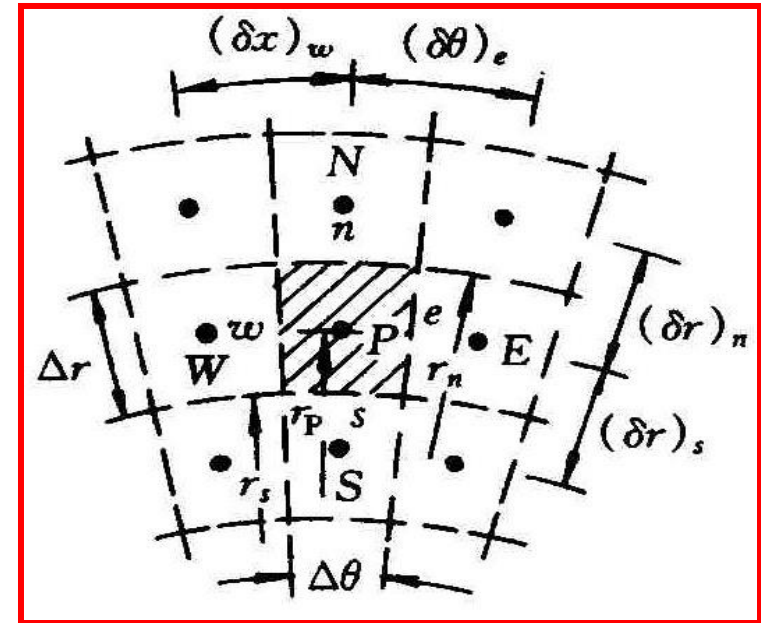

$$a_P T_P = a_E T_E + a_W T_W + a_N T_N + a_S T_S + b$$

$$a_E = \frac{r_P \Delta r}{(\Delta x)_e} \lambda_e$$

$$a_E = \frac{\Delta r}{r_P (\Delta \theta)_e} \lambda_e$$

4.2.2 Comparison between coefficients

Coefficients a_E of the three 2-D coordinates can be expressed as

$$a_E = \frac{\text{Interface conductivity} \times \text{E-W HC area}}{\text{Distance between Nodes E and P}}$$

It is the thermal conductance!

1. What's the difference between 3 coordinates

- (1) In polar coordi. θ is the arc (弧度), dimensionless, while in $x - y, x - r, x$ is dimensional!
- (2) In polar and cylindrical coordinates there are radius, while in Cartesian coordinate no any radius at all.

2. One way to unify the expression of coefficients

For this purpose we introduce two auxiliary (辅助的) parameters

(1) Scaling factor (x-方向标尺因子)

Distance in x direction is expressed by $s_x \bullet \delta x$

For Cartesian and cylindrical coordinates: $s_x \equiv 1$;

For polar coordinate: $s_x = r$;

(2) In y-direction, a normal(名义上的) radius, R, is introduced.

For Cartesian coordi. $R=1$ For Cy. & Po. $R= r$

Then: E-W conduction distance: $s_x \bullet \delta x$

E-W conduction area: $R\Delta y / s_x$

4.2.3 Unified expressions for three 2-D coordinates

| Coordinate | Cartes. | Cy.Sym | Polar | Generalized |
|--------------------------|------------|-------------|-----------------|------------------|
| E-W Coord. | x | x | θ | X |
| S-N Coord. | y | r | r | Y |
| Radius | 1 | r | r | R |
| Scaling factor in x | 1 | 1 | r | SX |
| E-W distance | δx | δx | $r\delta\theta$ | $(\delta x)(SX)$ |
| S-N distance | δy | δr | δr | δY |
| E-W Conduct.area | Δy | $r\Delta r$ | Δr | $R\Delta Y / SX$ |

| | | | | |
|---------------------|---|--|---|---|
| S-N Conduct.area | Δx | $r\Delta x$ | $r\delta\theta$ | $R(\Delta X)$ |
| Volume of CV | $\Delta x\Delta y$ | $r\Delta x\Delta r$ | $r\Delta\theta\Delta r$ | $R\Delta X\Delta Y$ |
| a_E | $\frac{\Delta y}{(\Delta x)_e / \lambda_e}$ | $\frac{r\Delta r}{(\Delta x)_e / \lambda_e}$ | $\frac{\Delta r}{(\Delta\theta)_e r / \lambda_e}$ | $\frac{R\Delta Y}{(SX)^2 (\Delta X)_e / \lambda_e}$ |
| a_N | $\frac{\Delta x}{(\Delta y)_n / \lambda_n}$ | $\frac{r\Delta x}{(\Delta r)_n / \lambda_n}$ | $\frac{r\Delta\theta}{(\Delta r)_n / \lambda_n}$ | $\frac{R\Delta X}{(\delta Y)_n / \lambda_n}$ |
| a_P^0 | $\rho c R\Delta X\Delta Y / \Delta t$ | | | |
| b | $S_c R\Delta X\Delta Y$ | | | |

If coding by this way, then by setting up a variable, **MODE**, computer will automatically deal with the three coordinates according to **MODE**:

In our teaching code, it is set up as follows:

| MODE | 1(x-y) | 2(x-r) | 3(theta-r) |
|-------------|---------------|---------------|-------------------|
| R | 1 | r | r |
| SX | 1 | 1 | r |

Commercial software usually adopts the similar method to deal with coefficients in different coordinates.

4.3 Treatments of Source Term and B.C.

4.3.1 Linearization of non-constant source term

1. Linearization (线性化) method

2. Discussion

3. Examples of linearization method

4.3.2 Treatments of 2nd and 3rd kind of B.C. for closing algebraic equations

1. Supplementing(补充) equations for
boundary points

2. Additional source term method (ASTM)

4.3 Treatments of Source Term and B.C.

4.3.1 Linearization of non-constant source term

1. Linearization (线性化)

Importance of source term in the present method--"Ministry of portfolio(不管部长)": refer to (指) any terms which can not be classified as one of the transient, diffusion or convection terms.

Linearization: for CV. P its source term is expressed as:

$$S = S_C + S_P \phi_P, \quad S_P \leq 0$$

S_C, S_P are constants for each CV, S_P is the slope(斜率) of the curve $S = f(\phi)$

For the curve $S = f(T)$

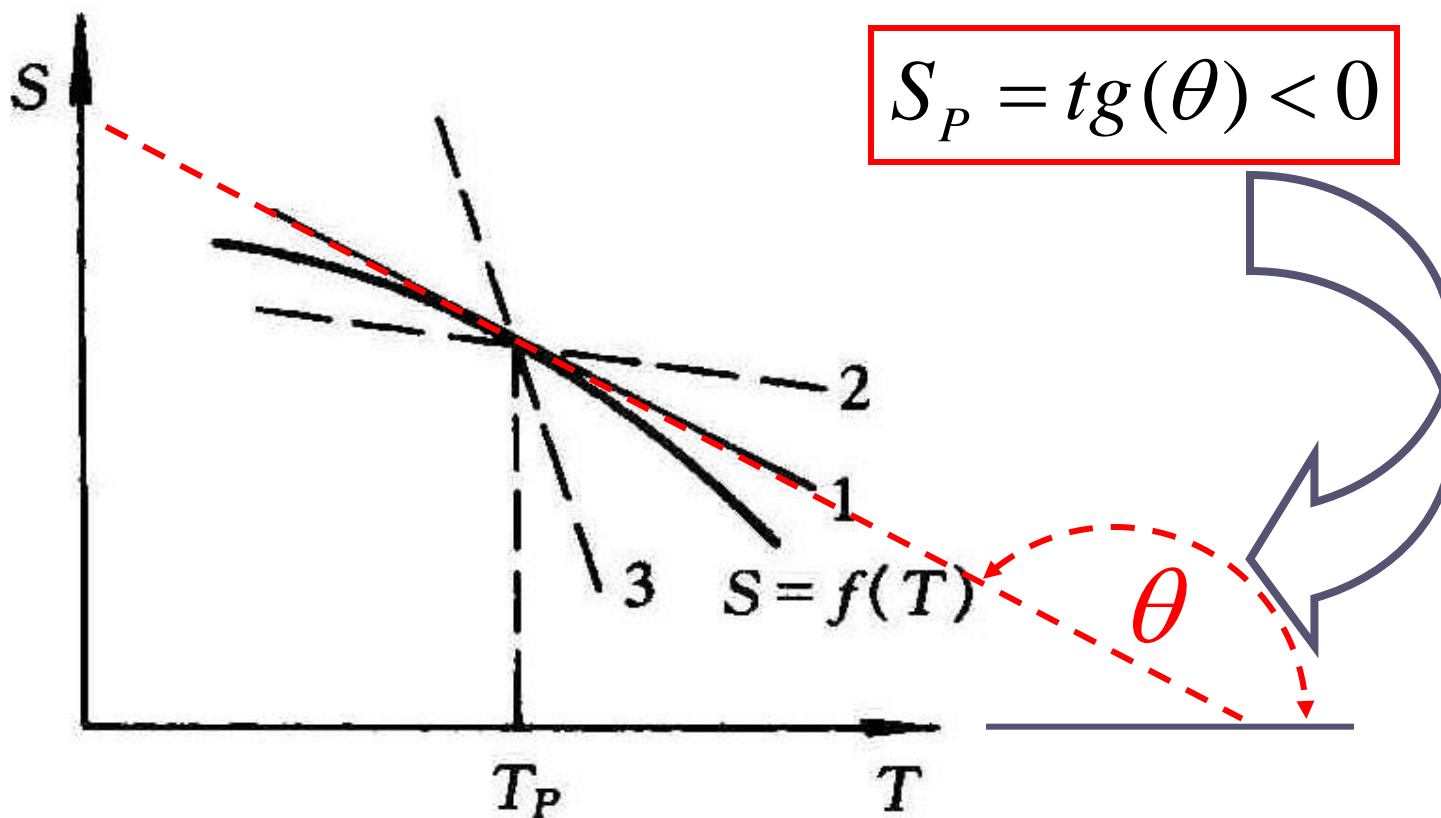

2. Discussion on linearization of source term

(1) For variable source term , $S = f(T)$, **linearization is better than taking previous value**, $S = f(T_P^*)$.

There is one time step lag (迟后) between

$$S = S_C + S_P T_P \text{ and } S = f(T^*) .$$

(2) Any complicated function can be approximated by a linear function, and **linearity is also required by deriving linear algebraic equations.**

(3) $S_P \leq 0$ is required by the convergence condition for solving the algebraic equations.

The sufficient condition for obtaining converged solution by iterative method for the algebraic equations like:

$$a_P \phi_P = \sum a_{nb} \phi_{nb} + b$$

is that: $a_P \geq \sum a_{nb}$

Since in our method:

$$a_P = \sum a_{nb} - S_P \Delta V$$

Thus $S_P \leq 0$ will ensure(确保) the above sufficient condition.

(4) If a practical problem has $S_P > 0$, then
an artificial(人为的) negative S_p may be introduced.

(5) Effect of the absolute value of S_p on the
convergence speed

Iteration equation:
$$\phi_P = \frac{\sum a_{nb} \phi_{nb} + b}{\sum a_{nb} - S_P \Delta V}$$

$|S_P|$  **Denominator(分母) increases, difference
between two successive iterations decreases;
hence convergence speed decreases;**

With given iteration number, it is favorable (利于) to get
the converged solution for **highly nonlinear problem.**

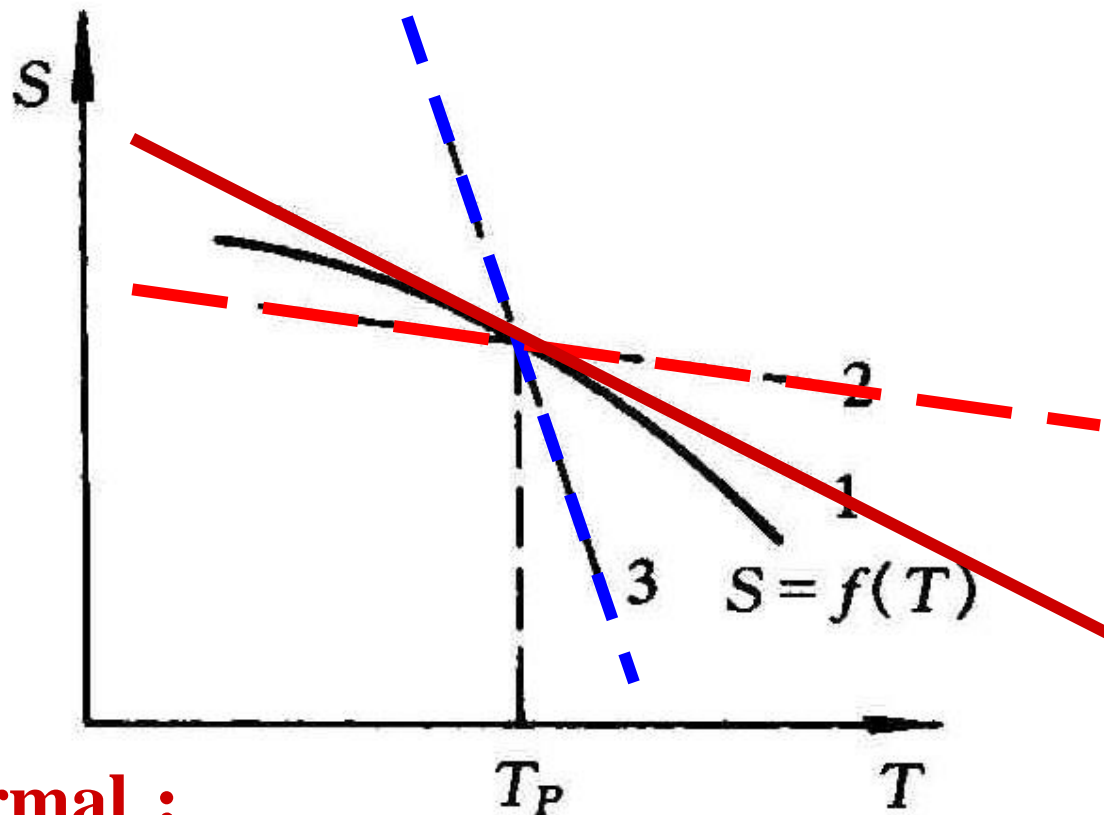

Curve 1--**normal** ;

Curve 3-- Absolute value of S_p increases — It is in favor of getting a converged solution for nonlinear case, while **speed of convergence decreases**.

Curve 2 --Absolute value of S_p decreases, it is in favor of speed up iteration, but **takes a risk(风险) of divergence!**

3. Examples of linearization

(1) $S = 3 - 5T$; $S_C = 3$, $S_P = -5$

(2) $S = 3 + 5T$;

Different practices:

$$\left\{ \begin{array}{l} S_C = 3 + 5T^*, S_P = 0 \\ S_C = 3 + 7T^*, S_P = -2 \\ \dots\dots\dots \end{array} \right.$$

(3) $S = 4 - 2T^2$;

$$S = S^* + \left(\frac{dS}{dT}\right)^* (T - T^*) = [4 - (2T^*)^2] + (-4T^*)(T - T^*)$$

$$= 4 - 2T^{*2} + 4T^{*2} - 4T^*T = \underbrace{4 + 2T^{*2}}_{S_C} - \underbrace{4T^*T}_{S_P}$$

Recommended

4.3.2 Treatments of 2nd and 3rd kind of B.C. for closing algebraic equations

For 2nd and 3rd kinds of B.C., the boundary temperatures are not known, while they are involved in the inner node equations. Thus the resulted algebraic equations are not closed (方程组不封闭).

1. Supplementing (增补) equations for boundary nodes.

Adopting the CV to obtain boundary nodes equation.

(1) Practice A

Taking the heat into the solution region as positive.

Source

$$q_B + \lambda \frac{T_{M_1-1} - T_{M_1}}{\delta x} + \Delta x \cdot S = 0$$

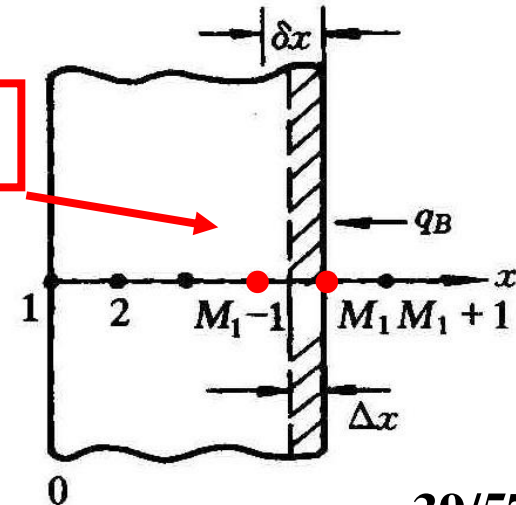

Yields:
$$T_{M1} = T_{M1-1} + \frac{\delta x \cdot \Delta x \cdot S}{\lambda} + \frac{q_B \cdot \delta x}{\lambda}$$

The T.E. of this discretized equation is: $O(\Delta x^2)$

For 3rd kind B.C., according to Newton's law of cooling:

$$q_B = h(T_f - T_{M1}) \quad \text{(Heat into the region as +)}$$

Substituting q_B into the above equation, and rearranging:

$$T_{M1} = \frac{T_{M1-1} + \frac{\delta x \cdot \Delta x \cdot S}{\lambda} + \left(\frac{h \cdot \delta x}{\lambda}\right)T_f}{\frac{h \cdot \delta x}{\lambda} + 1}$$

(2) Practice B

Brief review of 2017-10-09 lecture key points

1. Harmonic mean for the interface diffusivity

$$\frac{(\delta x)_e}{\lambda_e} = \frac{(\delta x)_{e^+}}{\lambda_E} + \frac{(\delta x)_{e^-}}{\lambda_P}$$

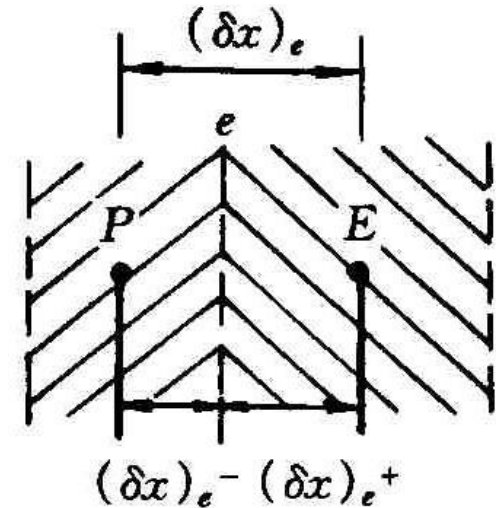

2. Only fully implicit scheme can guarantee stable and physically meaningful numerical solution.

3. Linearization of non-constant source term

$$S = S_C + S_P \phi_P, \quad S_P \leq 0$$

The requirement of negative S_P is to guarantee the convergence of the iterative solution process for the algebraic equations.

4. Unified coding method for three 2-D coordinates

(1) Introducing a scaling factor in x-direction

Distance in x direction is expressed by $s_x \bullet \delta x$

(2) Introducing a normal radius, R, in y-direction

For cartesian coordinate $R=1$

For cylindrical and polar coordinates $R=r$

The **volume of boundary node in Practice B is zero**, thus setting zero volume of the boundary nodes in the above equation:

$$q_B + \lambda \frac{T_{M1-1} - T_{M1}}{\delta x} + \Delta x \bullet S = 0$$

yields:

for 2nd kind boundary —

$$T_{M1} = T_{M1-1} + \frac{q_B \bullet \delta x}{\lambda}$$

for 3rd kind boundary —

$$T_{M1} = \frac{T_{M1-1} + \left(\frac{h \bullet \delta x}{\lambda}\right) T_f}{1 + \frac{h \bullet \delta x}{\lambda}}$$

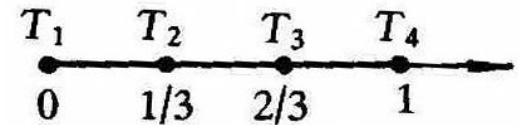

(a)

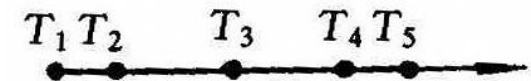

(b)

Zero boundary CV

The above discretized forms have 2nd order accuracy.

(3) Example 4-4

[Known] $\frac{d^2T}{dx^2} - T = 0; x = 0, T = 0; x = 1, \frac{dT}{dx} = 1$

[Find] Temperatures of 2-3 nodes in the region

[Solution]

Practice A, 2 inner nodes,

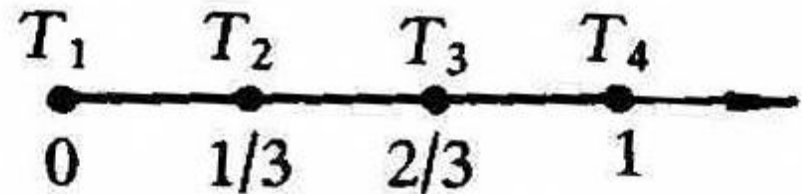

T_2, T_3 Adopting 2nd -order accuracy

T_4 Adopting 1st order : $\frac{T_4 - T_3}{1/3} = 1 \longrightarrow T_4 - T_3 = 1/3$

T_4 Adopting 2nd order: $T_{M1} = T_{M1-1} + \frac{\delta x \cdot \Delta x \cdot S}{\lambda} + \frac{q_B \cdot \delta x}{\lambda}$

Question 1: what is the source term?

Boundary node has a half CV,
From $\frac{d^2T}{dx^2} - T = 0$ $S = -T_4$

Question 2: what is the heat flux?

Then from $T_{M1} = T_{M1-1} + \frac{\delta x \cdot \Delta x \cdot S}{\lambda} + \frac{q_B \cdot \delta x}{\lambda}$

$$q = \lambda \frac{dT}{dx} = 1 \times 1 = 1$$

We have

$$T_4 = T_3 - \frac{\frac{1}{3} \cdot \frac{1}{6} \cdot T_4}{1} + \frac{1 \cdot \frac{1}{3}}{1} \rightarrow \frac{19}{18} T_4 - T_3 = \frac{1}{3}$$

Effect of order of accuracy of B.C. on the numerical solution

| Scheme | T_2 | T_3 | T_4 |
|-------------|---------------|---------------|---------------|
| Analytical | 0.2200 | 0.4648 | 0.7616 |
| First order | 0.2477 | 0.5229 | 0.8563 |
| 2nd order | <u>0.2164</u> | <u>0.4570</u> | <u>0.7408</u> |

Practice B, three CVs, three inner nodes

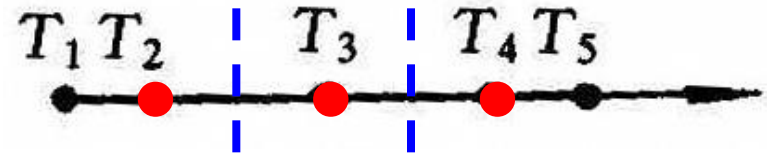

For inner nodes T_2, T_3, T_4 adopting 2nd order;

T_5 can be calculated from $T_{M1} = T_{M1-1} + \frac{q_B \cdot \delta x}{\lambda}$

Numerical results are much closer to exact solution!

| Scheme | T_2 | T_3 | T_4 | T_5 |
|------------|---------------|---------------|---------------|---------------|
| Exact | 0.1085 | 0.3377 | 0.6408 | 0.7616 |
| Practice B | <u>0.1084</u> | <u>0.3372</u> | <u>0.6035</u> | <u>0.7702</u> |

Question: How to get the discretized eqs. for 2, 4?

2. Additional source term method (ASTM 附加源项法)

(1) Basic idea

Regarding the heat going into the region by 2nd or 3rd kind B.C. as the **source term** of the first inner CV; Cutting the connection between inner node and boundary, i.e, regarding the boundary as adiabatic, hence eliminating (消除) the wall temp. from discretized eqs. of inner nodes.

(2) Analysis for 2nd kind B.C.

$$a_P T_P = a_E T_E + a_W T_W + a_N T_N + a_S T_S + b$$

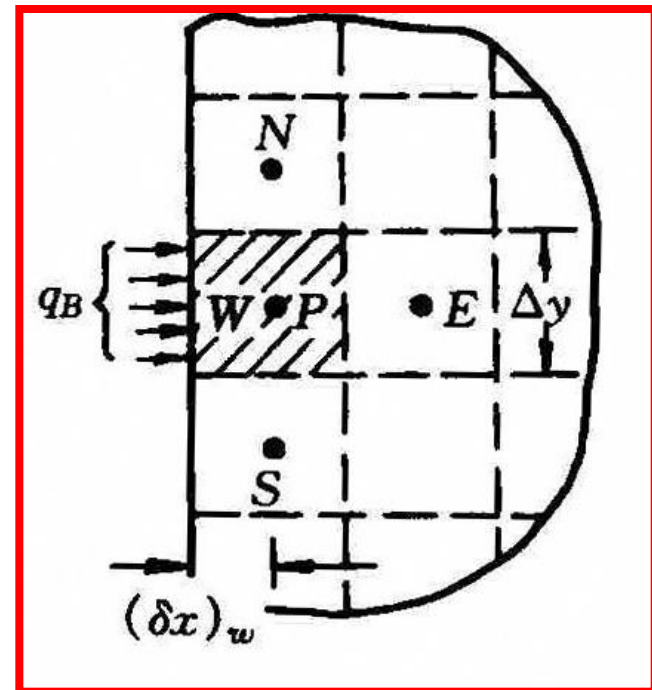

where $a_W = \frac{\lambda_B \Delta y}{(\delta x)_B}$. Subtracting $a_W T_P$ from above eq.

$$(a_P - a_W)T_P = a_E T_E + a_N T_N + a_S T_S + \underline{a_W (T_W - T_P)} + b$$

$$a_W (T_W - T_P) = \Delta y \frac{\lambda_B (T_W - T_P)}{(\delta x)_B} = q_B \Delta y \quad (\text{entering as } +)$$

$$a'_P T_P = a_E T_E + a_N T_N + a_S T_S + \frac{q_B \Delta y}{\Delta V} \Delta V + S_C \Delta V$$

$$a'_P = a_P - a_W$$

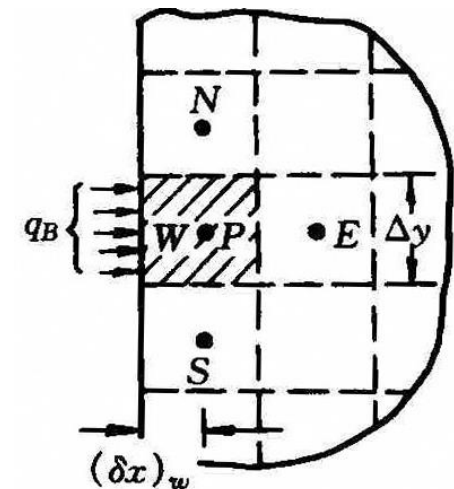
$$S_{C,ad}$$

Summary of ASTM for 2nd kind B.C.:

- (1) Adding a source term in discretized eq. $S_{C,ad} = \frac{q_B \Delta y}{\Delta V}$
- (2) Setting the conductivity of boundary node to be zero, leading to: $a_W = 0$
- (3) Discretizing inner nodes as usual.

(3) Analysis for 3rd kind B.C.

$$q_B = h(T_f - T_W) \quad (\text{Entering as } +)$$

$$q_B = \frac{T_f - T_W}{\frac{1}{h}} = \frac{T_W - T_P}{\frac{(\delta x)_B}{\lambda_B}} = \frac{T_f - T_P}{\frac{1}{h} + \frac{(\delta x)_B}{\lambda_B}}$$

Substituting the result to the source term for 2nd kind B.C.,

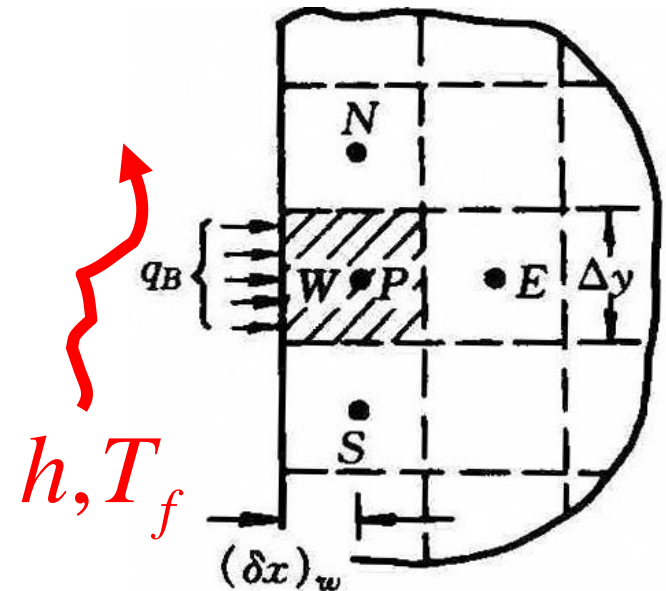

$$a'_P T_P = a_E T_E + a_N T_N + a_S T_S + \frac{q_B \Delta y}{\Delta V} \Delta V + S_C \Delta V$$

$$q_B = \frac{T_f - T_P}{\frac{1}{h} + \frac{(\delta x)_B}{\lambda_B}}$$

Substituting q_B

Moving T_P to left hand, T_f kept as is, yields:

$$\left\{ a'_P + \frac{\Delta y}{\Delta V \bullet [1/h + (\delta x)_B / \lambda_B]} \Delta V \right\} T_P = a_E T_E + a_N T_N + a_S T_S + \left\{ S_C + \frac{\Delta y \bullet T_f}{\Delta V [1/h + (\delta x)_B / \lambda_B]} \right\} \Delta V$$

From q_B

$$\frac{\Delta y}{\Delta V \bullet [1/h + (\delta x)_B / \lambda_B]} \Delta V_P = - \frac{-\Delta y}{\Delta V \bullet [1/h + (\delta x)_B / \lambda_B]} \Delta V_P$$

$$S_{P,ad} = - \frac{\Delta y}{\Delta V \bullet [1/h + (\delta x)_B / \lambda_B]}$$

$$(a_P = a'_P - S_P)$$

$$S_{C,ad} = \frac{\Delta y \bullet T_f}{\Delta V \left[\frac{1}{h} + \frac{(\delta x)_B}{\lambda_B} \right]}$$

(4) Implementing procedure of ASTM

- Determining ASTs for CV neighboring to boundary

$$S_{C,ad}, S_{P,ad},$$

- Adding them into source term of related CV

$$S_C \leftarrow S_C + S_{C,ad}$$

**Accumulative
addition (累加)**

- **Setting the conductivity of the boun. node to be zero;**
- **Deriving the discretized eqs. of inner nodes as usual,
Solving the algebraic eqs. for inner nodes;**
- **Using Newton' law of cooling or Fourier eq. to get
the boundary temperatures from the converged
solution of inner nodes.**

(5) Application examples of ASTM

In FVM when Practice B is adopted to discretize space, the 2nd and 3rd kinds of B.C. can be treated by ASTM, which can greatly accelerate(加速) the solution process.

Extended applications of ASTM

(1) Dealing with irregular(不规则) boundary

When the code designed for regular region is used to simulated irregular domain, ASTM can be used to treat the B.C.

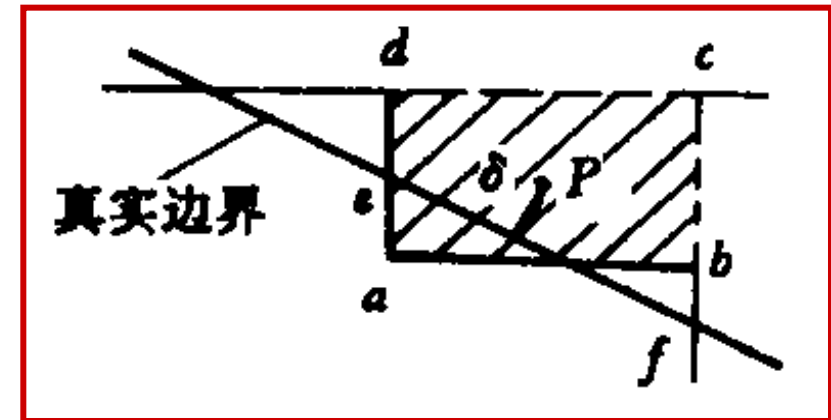
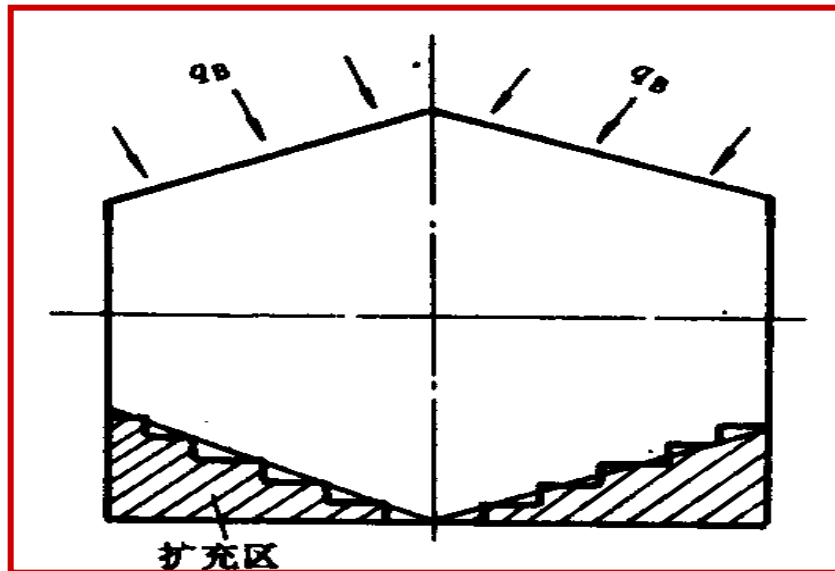

Prata A T. and Sparrow EM. Heat transfer and fluid flow characteristics for an annulus of periodically varying cross section. **Num Heat Transfer**, 1984, 7:285-304

(2) Simulating combined conduction, convection and radiation problem

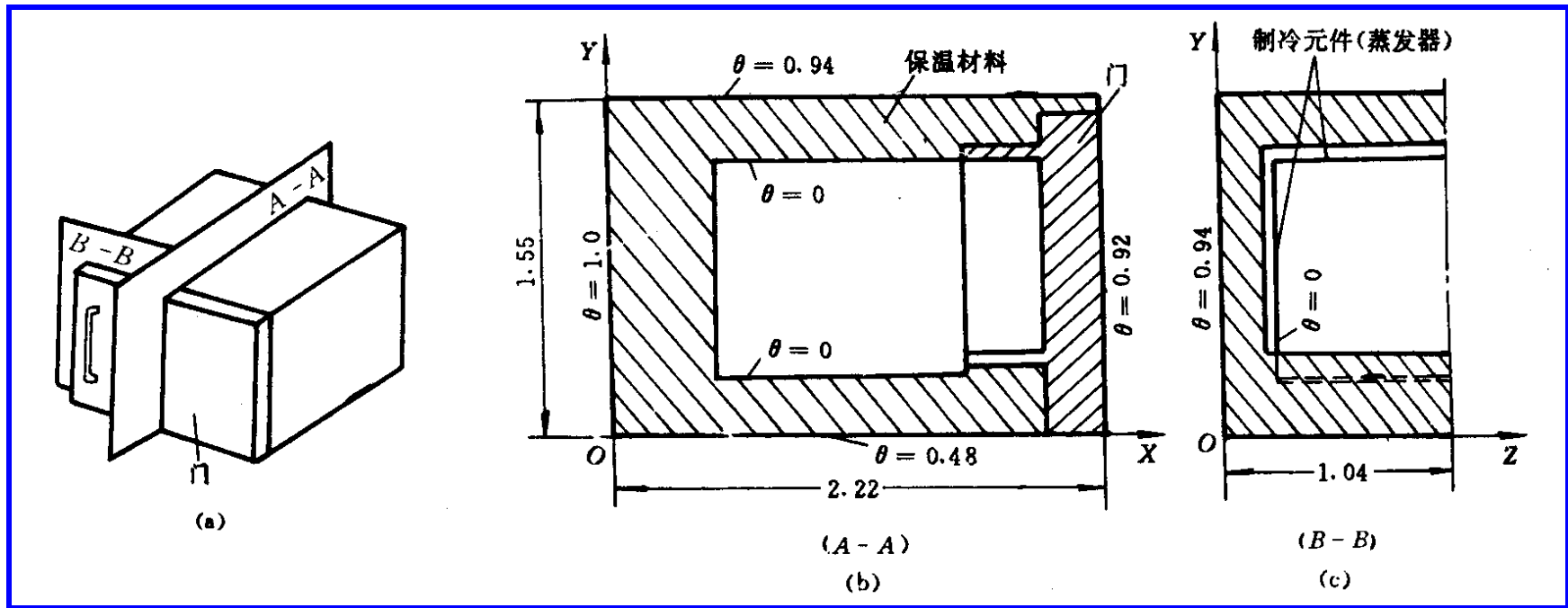

[1] 陶文铨, 李茏. 处理区域内部导热与辐射联合作用的数值方法. **西安交通大学学报**, 1983, 19 (3) : 65-76

[2] 杨沫 王育清 傅燕弘 陶文铨. 家用冰箱冷冻冷藏室温度场的数值模拟. **制冷学报**, 1991年, (4):1-8

[3] Zhao CY, Tao WQ. Natural convections in conjugated single and double enclosures. **Heat Mass Transfer**, 1995, 30 (3): 175-182

(3) Determining the efficiency of slotted (开缝) fin

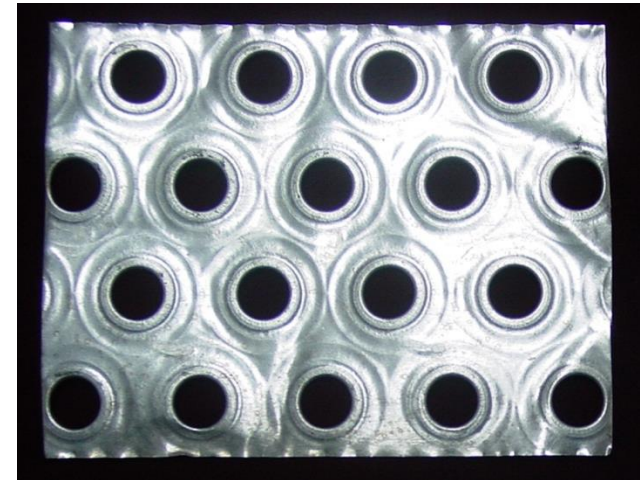
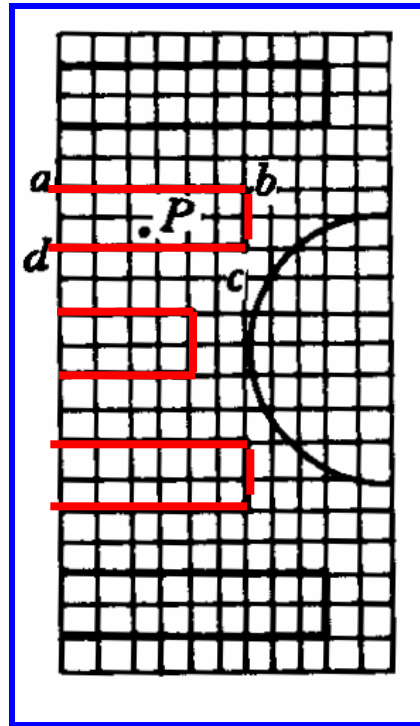
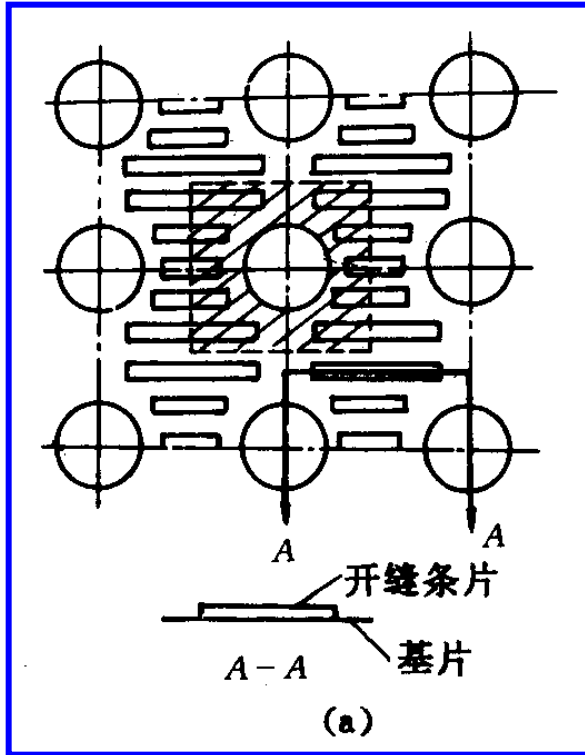

Tao WQ, Lue SS .Numerical method for calculation of slotted fin efficiency in dry condition. **Numerical Heat Transfer, Part A, 1994, 26 (3): 351-362**

(4) Simulating heat transfer and fluid flow in a welding pool (焊池)

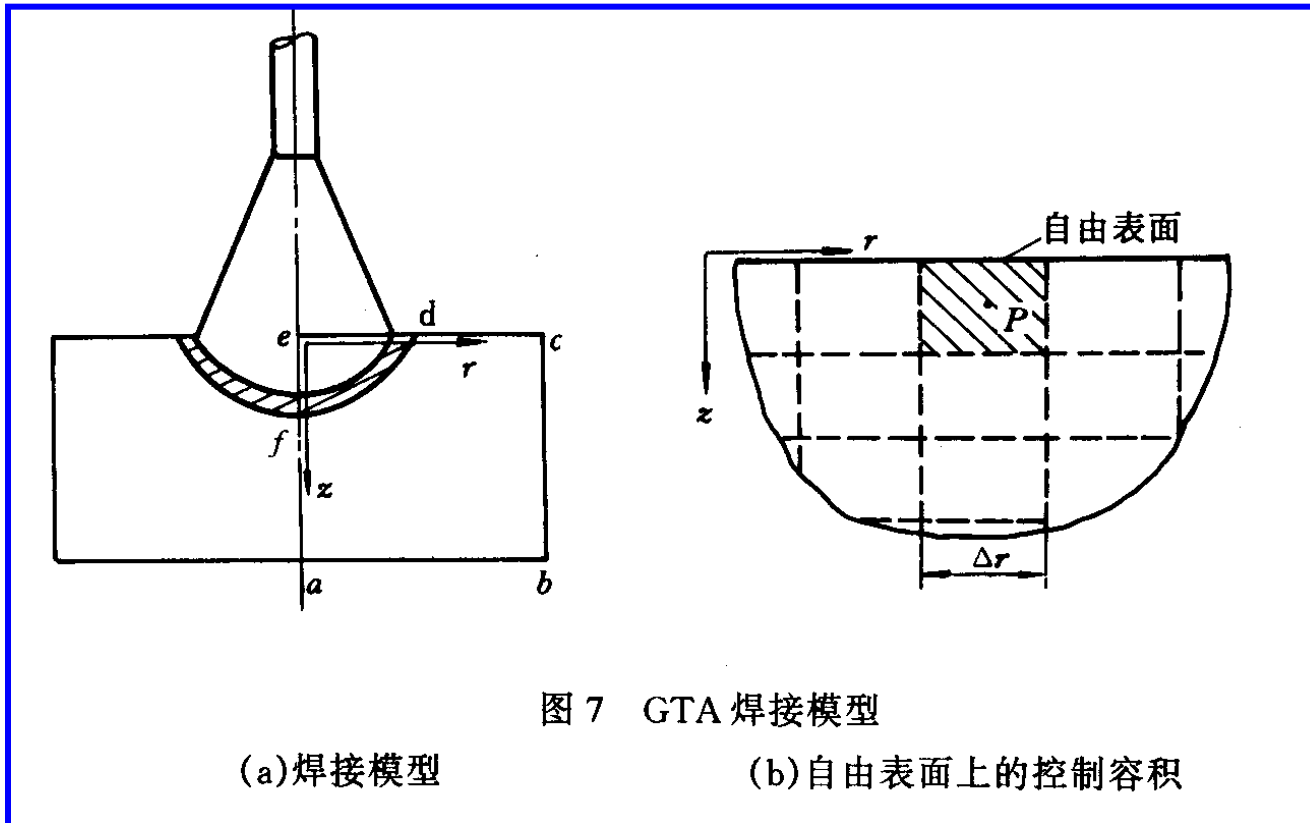

Lei Y P, Shi Y W. Numerical treatment of the boundary conditions and source term of a spot welding process with combining buoyancy – Marangoni flow. **Numerical Heat Transfer, Part b, 1994, 26 : 455-471**

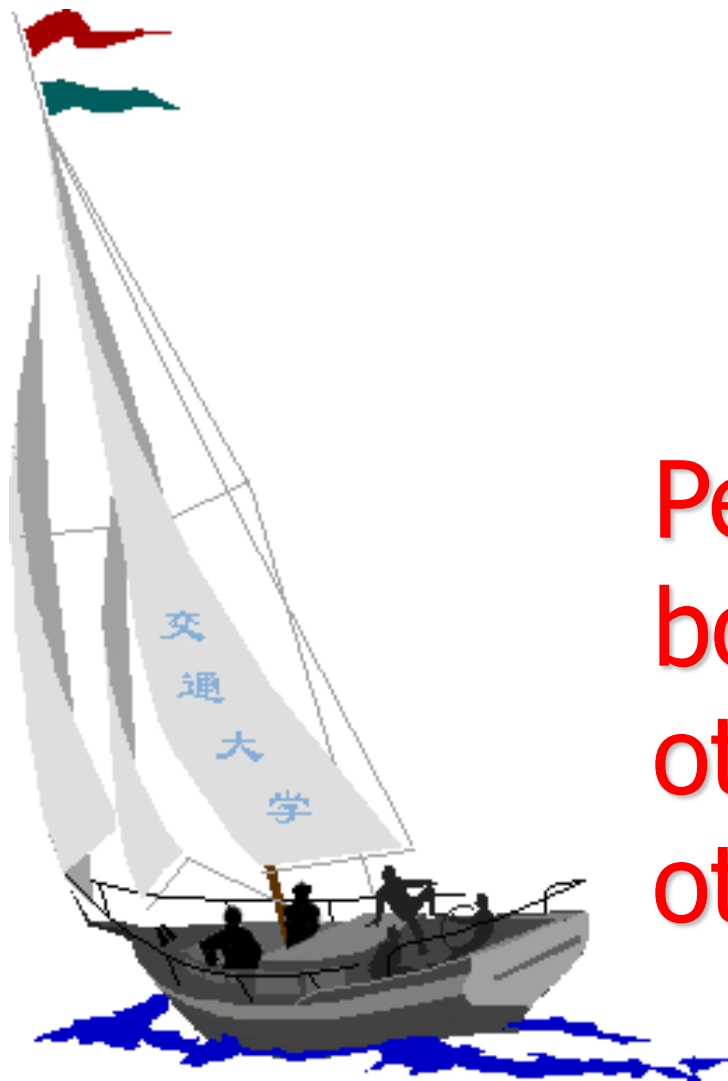

同舟共济 渡彼岸!

People in the same
boat help each
other to cross to the
other bank, where....