

Numerical Heat Transfer (数值传热学)

Chapter 8 General Code for 2D Elliptical Fluid Flow and Heat Transfer (1)



Instructor Tao, Wen-Quan

Key Laboratory of Thermo-Fluid Science & Engineering
Int. Joint Research Laboratory of Thermal Science & Engineering
Xi'an Jiaotong University
Innovative Harbor of West China, Xian

2021-Nov-16

Chapter 8 General Code for 2D Elliptical Fluid Flow and Heat Transfer Problems

8.1 Format Improvement of General Governing
Equation

8.2 Numerical Methods Adopted and Discretization
Equations

8.3 Code Structure and Module Functions

8.4 Grid System

8.5 Techniques Adopted in the Code

8.6 Methods of Application and Explanation of
MAIN Program

8.1 Format Improvement of the General Governing Equation

The G.E. we just in the previous chapters is:

$$\frac{\partial(\rho\phi)}{\partial t} + \text{div}(\rho\phi\vec{U}) = \text{div}(\Gamma_{\phi}^* \text{grad}\phi) + S_{\phi}^* \quad (1)$$

Equation	ρ	ϕ	Γ_{ϕ}^*	S_{ϕ}^*
Continuity equation	ρ	1	0	0
Momentum eqn. (x direction)	ρ	u	μ	$\rho f_x - \frac{\partial p}{\partial x}$
Momentum eqn. (y direction)	ρ	v	μ	$\rho f_y - \frac{\partial p}{\partial y}$
Energy equation	ρ	T	<u>λ/c_p</u>	S_T/c_p

When the fluid heat capacity is not constant, numerical results may not satisfy the conservation condition.

8-1 Analysis for energy equation

2D transient convection diffusion equation:

$$\frac{\partial(\rho c_p T)}{\partial t} + \frac{\partial(\rho c_p u T)}{\partial x} + \frac{\partial(\rho c_p v T)}{\partial y} = \frac{\partial}{\partial x} \left(\lambda \frac{\partial T}{\partial x} \right) + \frac{\partial}{\partial y} \left(\lambda \frac{\partial T}{\partial y} \right) + S_T. \quad (2)$$

Reforming into the previous format of G.E.:

$$\frac{\partial(\rho T)}{\partial t} + \frac{\partial(\rho u T)}{\partial x} + \frac{\partial(\rho v T)}{\partial y} = \frac{\partial}{\partial x} \left(\frac{\lambda}{c_p} \frac{\partial T}{\partial x} \right) + \frac{\partial}{\partial y} \left(\frac{\lambda}{c_p} \frac{\partial T}{\partial y} \right) + \frac{S_T}{c_p}$$

$$-\frac{1}{c_p^2} \left[\rho c_p T \frac{\partial c_p}{\partial t} + \left(\rho c_p u T - \lambda \frac{\partial T}{\partial x} \right) \frac{\partial c_p}{\partial x} + \left(\rho c_p v T - \lambda \frac{\partial T}{\partial y} \right) \frac{\partial c_p}{\partial y} \right]$$

This term was neglected in the previous G.E. (3)

When it can be neglected?

(1) C_p is constant;

(2) Or following three terms simultaneously equal zero:

$$\rho c_p u T - \lambda \frac{\partial T}{\partial x} = 0, \quad \rho c_p v T - \lambda \frac{\partial T}{\partial y} = 0 \quad \text{and} \quad \rho c_p T \frac{\partial c_p}{\partial t} = 0$$

(3) Or the sum of the three terms equal zero!

Obviously, such chances are quite limited! Hence, simulation results based on previous G.E. inherently include some errors!

8-2 Improved format of the general G.E.

The frame work (框架) of the previous general G.E. is retained (保留), but the diffusion coefficient is resumed to (恢复到) its original value by introducing a nominal density as follows:

$$\frac{\partial(\rho^* \phi)}{\partial t} + \text{div}(\rho^* \phi \vec{U}) = \text{div}(\Gamma_\phi \text{grad} \phi) + S_\phi^* \quad (4)$$

The new form of G.E. for different variables are:

Equation	ρ^*	ϕ	Γ_ϕ	S_ϕ^*
Continuity equation	ρ	1	0	0
Momentum eqn. (x direction)	ρ	u	μ	$\rho f_x - \frac{\partial p}{\partial x}$
Momentum eqn. (y direction)	ρ	v	μ	$\rho f_y - \frac{\partial p}{\partial y}$
Energy equation	ρc_p	T	λ	S_T

That is, now we regard ρc_p in the energy equation as a **general density**:

$$\frac{\partial(\rho c_p T)}{\partial t} + \frac{\partial(\rho c_p u T)}{\partial x} + \frac{\partial(\rho c_p v T)}{\partial y} = \frac{\partial}{\partial x} \left(\lambda \frac{\partial T}{\partial x} \right) + \frac{\partial}{\partial y} \left(\lambda \frac{\partial T}{\partial y} \right) + S_T.$$

Such a treatment is much better than taking Γ / c_p as a nominal diffusion coefficient and S_T / c_p as a nominal source term .

Li W, Yu B, Wang Y, et al. Communications in Computational Physics, 2012, 12(5): 1482-1494

8-3 Comparisons of numerical examples

For the same physical problems, adopting **the same** discretized scheme, algorithm, grid system, solution method, relaxation factors and the same convergence criteria, the only difference is in the G.E., Eqs.(1) and (4):

1) Example 1 ---Natural convection in enclosure with a moving lid and variable heat capacity

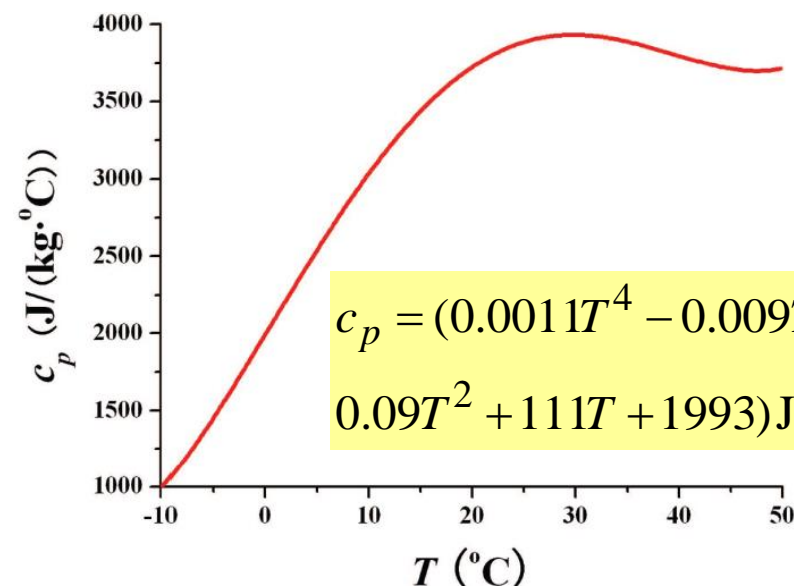
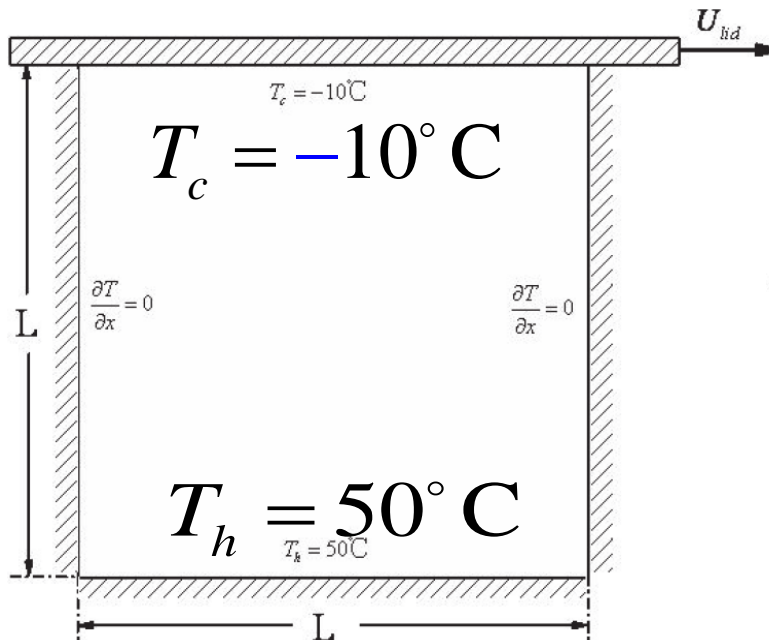

$$c_p = (0.0011T^4 - 0.009T^3 + 0.09T^2 + 111T + 1993) \text{J}(\text{kg} \cdot \text{K})^{-1}$$

Numerical methods: QUICK for convection term; CD for diffusion term, SIMPLE algorithm, 80x80 non-uniform grid system;

For G.E. of Eq. (1) fluid heat capacity is determined by takes five ways, including arithmetic mean.

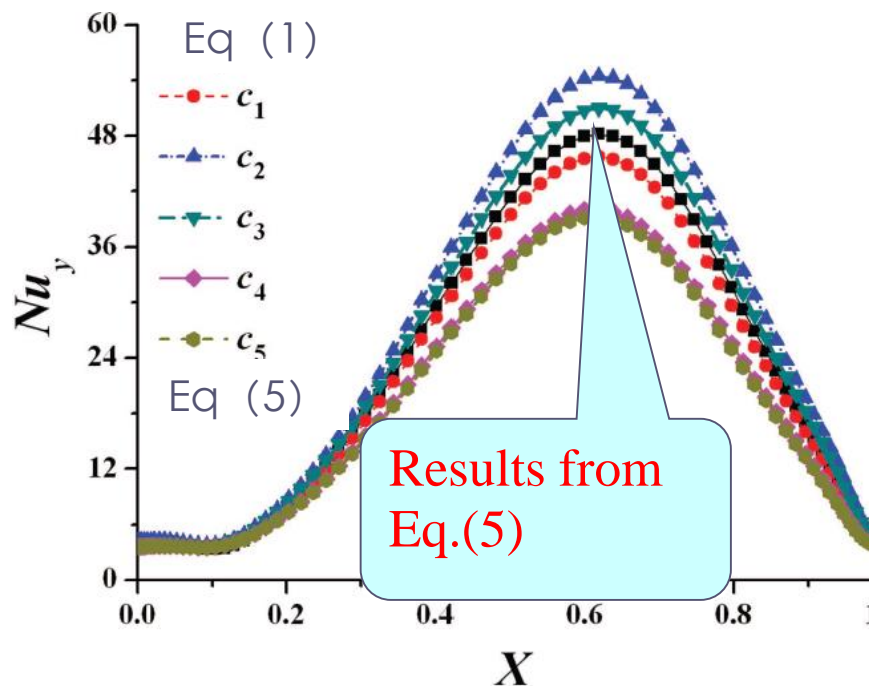

(a) Nusselt number

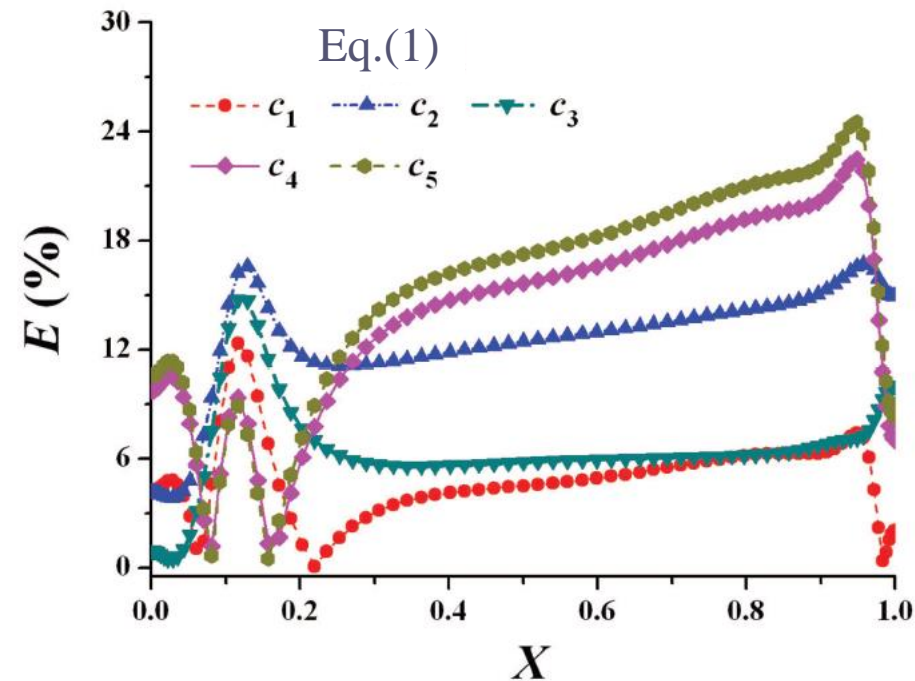

(b) Relative deviation

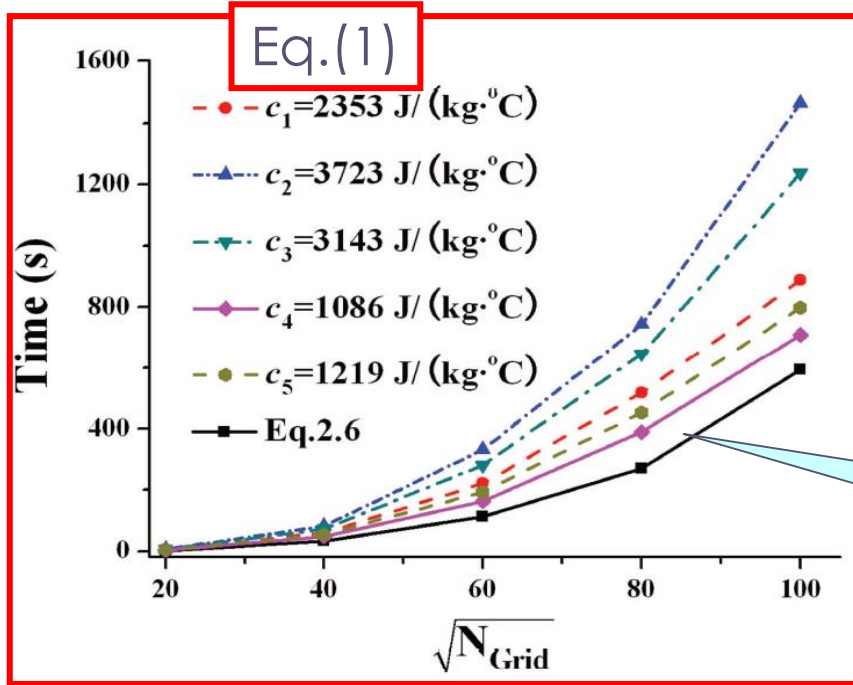

The convergence rate of the new G.E. is significantly higher than that of the previous format.

Results from Eq.(5)

2) Example 2 ---Conjugated problems(耦合问题)

Harmonic mean was derived from thermal conductivity. In the previous G.E., diffusivity is nominal, which is λ / c_p ; Thus for conjugated problem where fluid and solid are coupled, the harmonic mean should be revised its form as follows:

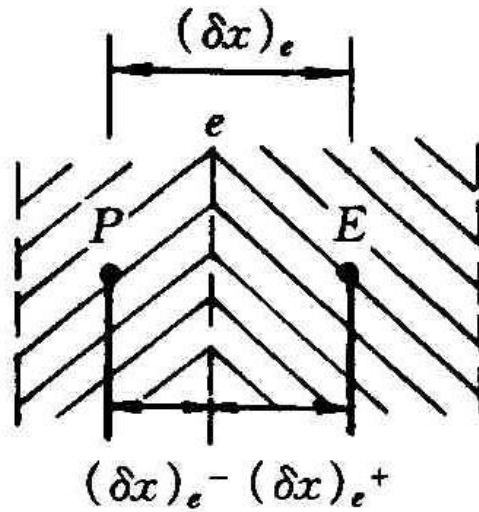

$$\frac{(\delta x)_e}{\lambda_e} = \frac{(\delta x)_{e^+}}{\lambda_E} + \frac{(\delta x)_{e^-}}{\lambda_P}$$

Harmonic mean

Harmonic mean for conjugated problem

$$\frac{(\delta x)_e}{\lambda / c_{pfe}} = \frac{(\delta x)_{e^+}}{\lambda_E / c_{pf}} + \frac{(\delta x)_{e^-}}{\lambda_P / c_{pf}}$$

For steady problems, such treatment is OK, while **for transient problem, it does not work.** In the frame work of new G.E. there is no such problem at all.

8.2 Numerical Methods Adopted in Teaching Code and Discretization Equations

8.2.1 Major numerical methods adopted

- 1. Primitive variable method:** Dependent variables are u, v, p ; and ω and ψ (vortex and stream-function) can be regarded as one of a general scalar variable ϕ ;
- 2. Practice B of domain discretization:** first determine the interfaces positions then the node positions ;
- 3. Control volume method for discretization:** Conservative convective schemes ;
- 4. Staggered grid:** three systems for u, v and p ;

5. Power-law for convection-diffusion discretization:

But easy to be replaced by CD, FUD or HS; For higher-order schemes, adopting defer correction method;

6. Linearization for source term:

$$S = S_C + S_P \phi_P, S_P \leq 0$$

7. Harmonic mean for interface diffusivity:

$$\frac{(\delta x)_e}{\lambda_e} = \frac{(\delta x)_{e^+}}{\lambda_E} + \frac{(\delta x)_{e^-}}{\lambda_P}$$

8. Fully implicit for transient problems: space derivatives are determined by the end instant of a time step;

9. Boundary conditions treated by 1st kind: adopting ASTM for 2nd and 3rd kinds of boundary conditions.

10.SIMPLER algorithm for coupling between velocity and pressure: at one iteration level, solving two Poisson equations--- pressure equation and pressure correction equation;

11.Iterative method for solving discretized equations:

- 1) Iterative method for solving algebraic equations (inner iteration) ;
- 2) Iterative method for nonlinearity (outer iteration);
 - (1) p' -underrelaxation for obtained solution;
 - (2) u, v, T -underrelaxation organized into solution procedure;

12.ADI with block correction for solving ABEqs.

8.2.2 Discretized equation of three kinds of variables

1. General scalar variable (标量) ϕ

For p , p' and all other scalar variables:

$$\frac{\partial(\rho^* \phi)}{\partial t} + \text{div}(\rho^* \phi \vec{U}) = \text{div}(\Gamma_\phi \text{grad} \phi) + S_\phi^*$$

$$a_P \phi_P = a_E \phi_E + a_W \phi_W + a_N \phi_N + a_S \phi_S + b$$

$$a_E = D_e A(|P_{\Delta e}|) + \begin{cases} -F_e, 0 \\ 0, F_e \end{cases} \quad a_W = D_w A(|P_{\Delta w}|) + \begin{cases} F_w, 0 \\ 0, -F_w \end{cases}$$

$$a_P = a_E + a_W + a_N + a_S + a_P^0 - S_P \Delta V$$

$$a_P^0 = \frac{\rho \Delta V}{\Delta t} \quad b = S_c \Delta V + a_P \phi_P^0$$

Note, for temperature **general density** is used to determine the coefficients.

Power-law scheme: $A(|P_\Delta|) = \left| 0, (1 - 0.1|P_\Delta|^5) \right|$

$$P_{\Delta e} = \frac{F_e}{D_e} = \frac{(\rho^* u A)_e}{(\Gamma A / \delta x)_e} = \frac{\rho_e^* u_e (\delta x)_e}{\Gamma_e} = \left(\frac{\rho^* u \delta x}{\Gamma} \right)_e$$

For temperature: $\Gamma_\phi = \lambda$ $\rho^* = \rho c_p$

2. Pressure & pressure correction equation

Based on mass conservation $(\rho u_i) / \partial x_i = 0$

For SIMPLER, substituting $u_e = u_e + (A_e / a_e)(p_P - p_E)$

into discretized mass conservation equation:

$$a_P p_P = a_E p_E + a_W p_W + a_N p_N + a_S p_S + b$$

$$b = (\rho A \tilde{u})_w - (\rho A \tilde{u})_e + (\rho A \tilde{v})_s - (\rho A \tilde{v})_n$$

$$a_E = (\rho A d)_e, a_P = \sum a_{nb}$$

Substituting $u_e = u_e^* + \frac{A_e}{a_e} (p_P' - p_E')$ into mass conservation equation:

$$a_P p_P' = a_E p_W' + a_W p_W' + a_N p_N' + a_S p_S' + b$$

Except b term, a_P and $a_{E,W,N,S}$ are the same as p -equation.

$$b = (\rho A u^*)_w - (\rho A u^*)_e + (\rho A v^*)_s - (\rho A v^*)_n$$

Remarks: The adopted mass conservation equation does not include $\partial \rho / \partial t$ and velocity correction neglects density effect. Thus this code only applicable to **incompressible flow**.

3. Momentum equation (taking u as example)

Governing equation:

$$\frac{\partial(\rho u)}{\partial t} + \text{div}(\rho \vec{u}u) = \text{div}(\eta \text{grad}u) - \frac{\partial p}{\partial x_i} + S_u$$

Discretized equation:

$$a_e u_e = a_{ee} u_{ee} + a_w u_w + a_{ne} u_{ne} + a_{se} u_{se} + b + A_e (p_P - p_E)$$

Volume of CV:

For general ϕ
scalar variable

$$\Delta V = \Delta x \cdot \Delta y$$

For u :

$$\Delta V = \delta x \cdot \Delta y$$

For v :

$$\Delta V = \Delta x \cdot \delta y$$

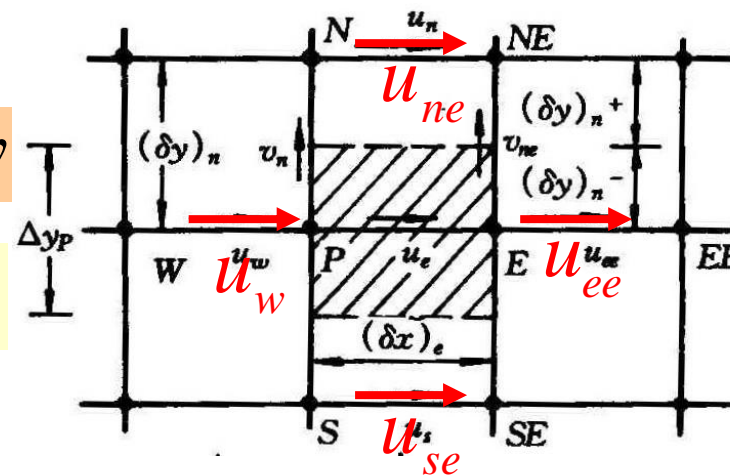

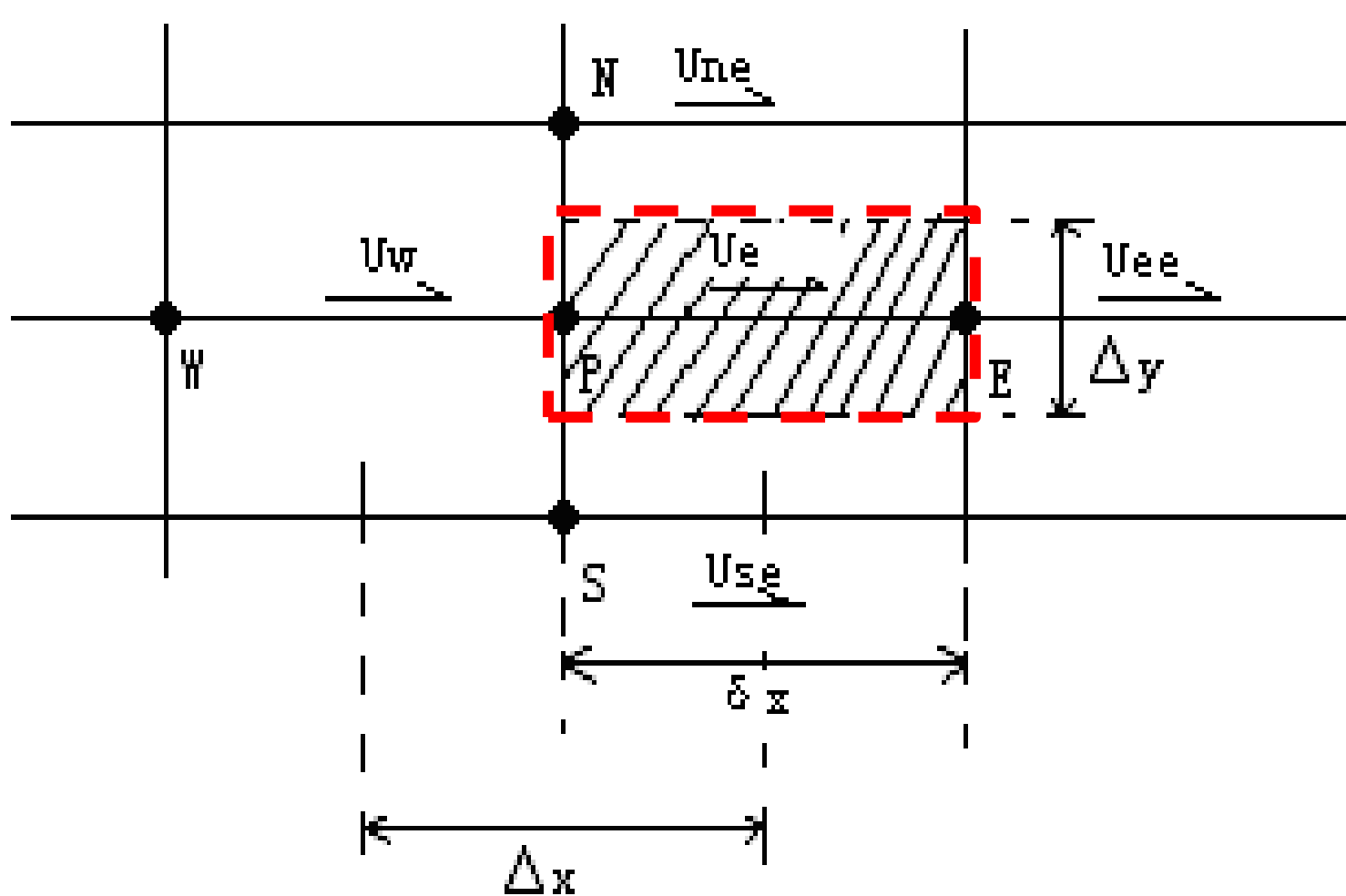

U-CV

8.2.3 Implementation of underrelaxation

For the convergence of nonlinearity iteration, changes of dependent variables of subsequent two iterations should not be too large. Underrelaxation can control the speed of this change:

Except the pressure correction equation, other discretized equations implement the underrelaxation during the solution procedure, which implies that the obtained solution has been underrelaxed:

$$\phi = \phi_P^0 + \alpha \left[\frac{\sum a_{nb} \phi_{nb} + b}{a_P} - \phi_P^0 \right]$$

Thus:

$$\left(\frac{a_P}{\alpha}\right)\phi_P = \sum a_{nb}\phi_{nb} + \underline{b} + (1-\alpha)\frac{a_P}{\alpha}\phi_P^0$$

New a_P, a_P'

New b, b'

Finally following equation is sent to the solver:

$$a_P'\phi_P = \sum a_{nb}\phi_{nb} + b'$$

But the underrelaxation of p' is performed after obtaining the solution of p' for the requirement of mass conservation:

$$p = p^* + \alpha_p p'$$

8.3 Code Structure and Module Functions

8.3.1 Major features of general code

8.3.2 Entire structure of the code

8.3.3 Basic function of major modules

8.3.4 Functions and limitations of the code

8.3 Code Structure and Module Functions

8.3.1 Major features of general code

General codes may be classified into two categories: One is commercial codes, the other is developed and used by researchers themselves; For both categories, the codes must have some generalities.

1. Introduction to commercial codes(商用软件)

There are more than sixty general commercial codes for fluid flows and heat transfers, among them most widely adopted ones include:

PHEONICS, FIDAP, FLUENT , CFX , STAR-CD etc.

Except FIDAP, which adopts FEM, the rest adopts

the finite volume method (FVM).

Six common features of commercial codes are:

- (1) There are flexible pre-processor (前处理器) and input system, including grid generation;
- (2) There is a good post-processor (后处理器), which is convenient for visualization of computational results;
- (3) There are convenient accesses for modules (模块接口) and users can add modules developed by themselves;
- (4) There is a large number of simulation examples, which is convenient for readers to follow;
- (5) There is a help system, including on-line one (在线帮助系统).

(6) There are complete error-proofing (防错) and test systems

2. The codes developed and used by researcher themselves are not so well generalized, but still possess some generalities.

Following techniques are often used:

(1) Adopting module structure

The so called module (模块) is a set of statements, which possess input, output and can implement some functions; For those who just call(调用) the module do not need to know the content of the module, only need to know what are the input and output of the module.

Subroutine (子程序) in FORTRAN is a kind of module. Module structure has a good readability (可读性), and is convenient for maintenance (维护).

(2) The inherent relationship between different modules should be loose (松宽的), so that changes in one module will not affect other modules.

(3) The code is divided into two parts: unchanged part and user;

Within the application range of the code, the unchanged part is kept as is (保持不变); It needs some input from user and provides output after some inner processing ; It is the blackbox for the users. The user part is closely related to the problem to be solved.

(4) Discretization, scheme and solution procedure should belong to three different modules.

Such a structure is convenient to the studies for the algorithm, scheme and solution methods of the algebraic equations.

(5) For major common variables default values (预置值) should be set up;

(6) A certain pre-process (前处理) and post-process (后处理) functions should be provided.

8.3.2 The entire structure of the code

Our teaching code belong to this category. It divides in to two parts: **MAIN Program (主程序)** and **User (用户)** .

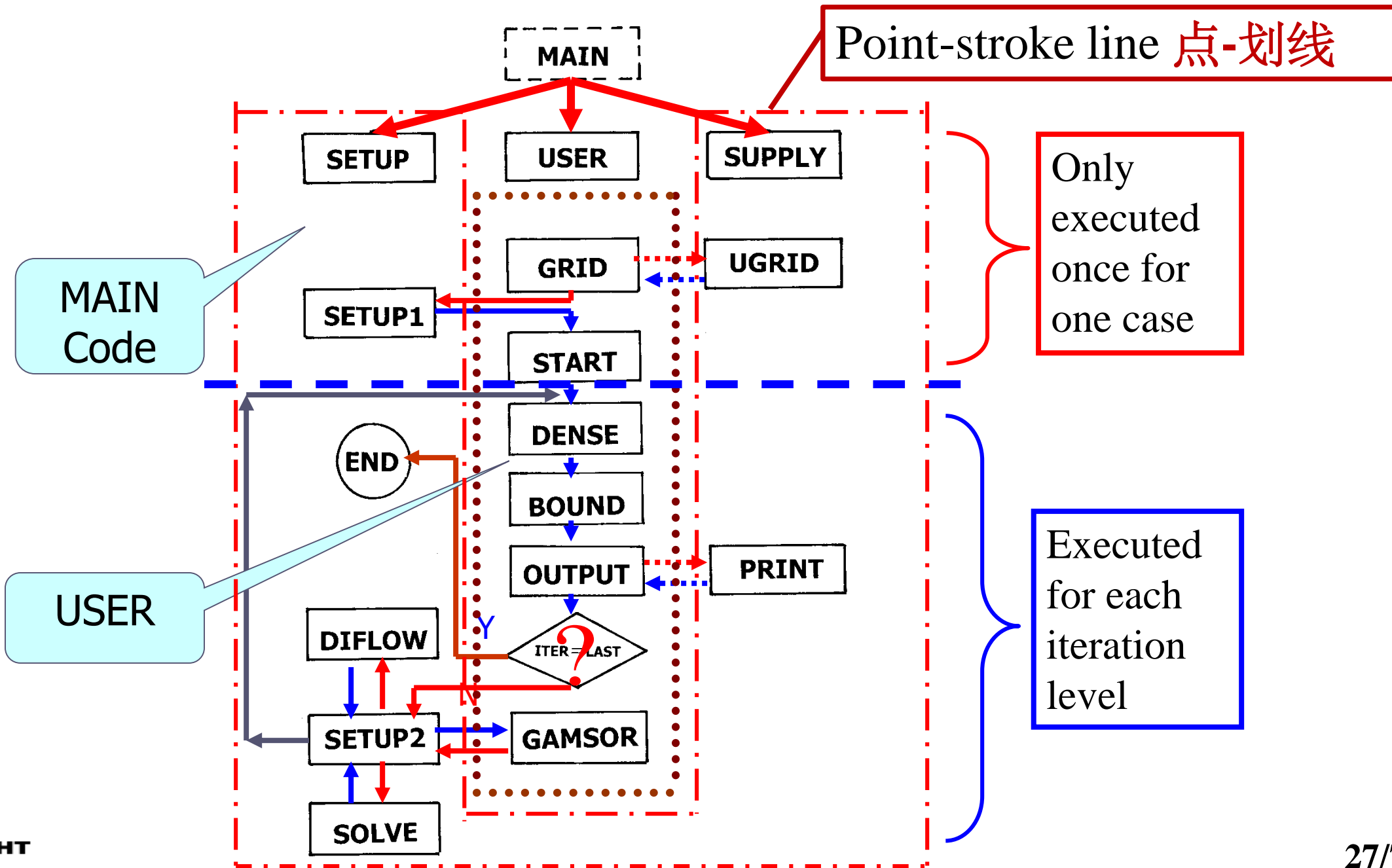

8.3.3 Basic functions (功能) of major modules

1 . “MODULE”

The ”MODULE” here with all characters in capital (大写) is a terminology (术语) which is a specially designed element in FORTRAN 90-95 for being quoted (被引用) . It is specially coded, independent of any subroutine of the main program .

The major feature of MODULE is that there is no any executive statement wherein (在MODULE 中没有任何执行语句) . Its major function is to be quoted (被引用) by other units of the program----When it is quoted all the contents in it will be copied to the unit quoting it, and the unit and MUDULE share the same memory.

Its functions in detail include:

- (1) Packaging data (封装数据);
- (2) Initializing data (数据初始化);
- (3) Declaring type of data (声明数据类型).

In FORTRAN 77 the sharing of data (数据共享) is executed by COMMON or EQUIVALENCE. They are not so efficient as MODULE, and are mistake-prone (容易出错).

“MODULE” is the most advanced method to share data between different units of a code.

MODULE structure is as follows:

MODULE module_name

● ● ● ● ● ●
● ● ● ● ● ●
● ● ● ● ● ●

Module name is composed of two parts,
with a hyphen(-) at bottom in between.

END MODULE

When a MODULE is going to be used:

USE module_name

IMPLICIT NONE

This means the type of all the variables in the module should be clarified individually(每个变量的类型必须逐一说明), and integers should be declared whether they are started with I,J,K,L,M, and N. In FORTRAN 77 when variables start with one of these characters they are regraded as integer.

2 . MAIN (different form MAIN Program)

- (1) Set up entire flow chart;
- (2) Judge whether terminating the execution of the code.

3 . GRID—Grid generation

- (1) Select coordinate: $MODE=1, 2, 3$ stands for x - y , r - x and $r-\theta$, respectively;
- (2) Set up length in x, y direction by XL, YL , respectively;
- (3) Set up number of nodes in x and y directions by $L1, M1$, respectively;
- (4) Set up interface positions of the main CV in x, y direction, respectively, by

XU(i), YV(j), $i=2, L1$, $j=2, M1$ (Practice B);

(5) Set up the starting radius $R(1)$ for $MODE \neq 1$

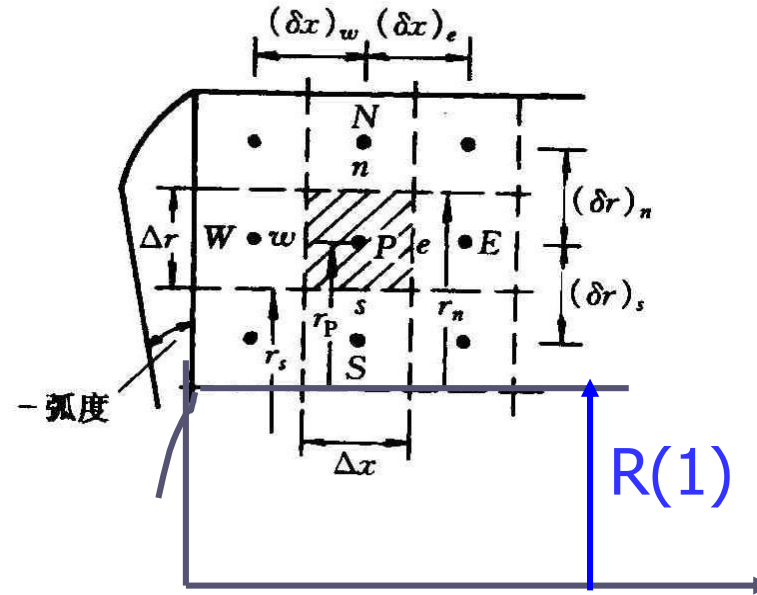
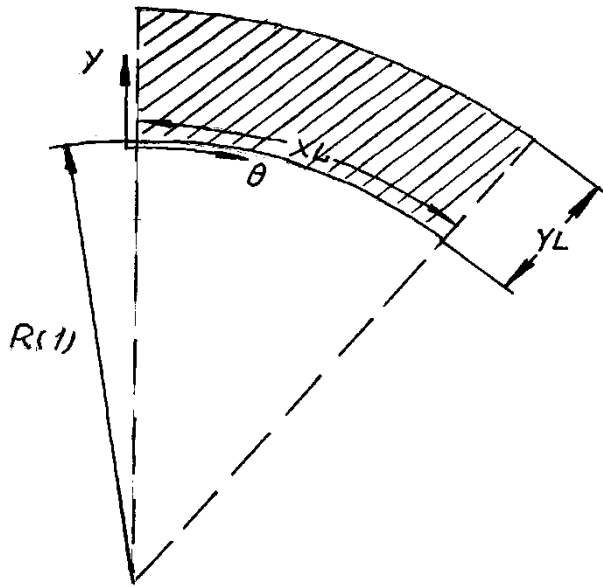

Polar coordinate

Cylindrical symmetric coordinate

(6) Call UGRID to generate interface position for uniform grid system.

4 . UGRID

Generate interface positions according to pre-specified XL, YL and L1, M1.

5 . SETUP 1

- 1) Set up 1-D arrays of geometric parameters which remain unchanged during iteration:
 - (1) Set up node positions by $X(i)$, $Y(j)$, $i=1 \cdot L1$, $j=1 \cdot M1$,
 - (2) Generate width of main CV by $XCV(i)$, $YCV(j)$,
 $i=2 \cdot L2$, $j=2 \cdot M2$;
 - (3) Determine distance between two neighboring nodes by $XDIF(i)$, $YDIF(j)$, $i=2 \cdot L1$, $j=2 \cdot M1$,
 $XDIF(i)=X(i)-X(i-1)$,
 $YDIF(j)=Y(j)-Y(j-1)$.

(4) Generate width of u , v CVs, respectively, by:

$$XCVS(i), i=3 \dots L2, \quad YCVS(j),$$

(5) Set up radius $R(j)$ in Y direction

and scaling factor $SX(j)$ in X

direction ;

(6) Calculate surface area normal

to X direction: $ARX(j)$

ARX(j)

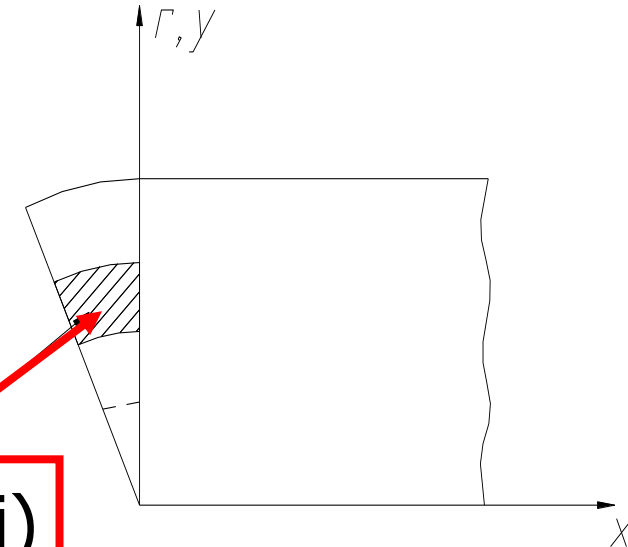

(7) Set up $XCVI(i)$, $XCVIP(i)$, which correspond to

$$(\delta x)_{e^-}, (\delta x)_{e^+}, \text{ respectively;}$$

(8) Establish interpolation functions, such as $FX(i)$,

$FXM(i)$, etc.

2) Set up initial values of u , v , p , p' , $RHO(i, j)$, $AP(i, j)$ (SP), $CON(i, j)$ (SC), $CP(i, j)$; Except $RHO(i, j)$ and $CP(i, j)$, the initial values of all others are zero; (20211116)

6 . START

- (1) Specify initial values for unsteady problems;
- (2) Assume initial values of iteration for steady-state problems; Give boundary conditions which do not change during iteration.

Above four modules (GRID,UGRID,SETUP1,START) are executed only once during simulation of one case.

7 . DENSE

Specify fluid density; For constant problem, it can be empty(空块), but should be kept as is. For energy equation,

the definition of the nominal density is conducted in the **MAIN program**. If the actual density is a function of temperature, it should be defined in this module.

8 . BOUND

Set up boundary conditions for all variables.

9 . OUTPUT

(1) For every outer iteration output some representative results for observation of convergence;

Solution procedure with a fixed set of coefficients of ABEqs is called one outer iteration. After finishing each outer iteration, the coefficients are updated and the next outer iteration begins. The value of the indicator ITER is added by 1.

(2) Compute some special 2nd quantities: h, q, Nu, f , etc.;

(3) Call PRINT, output 2-D fields.

10 . PRINT

Output simulation results.

11 . SETUP2 (Key module of MAIN Program)

- (1) Call GAMSOR to determine Γ_ϕ, S_P, S_C ;
- (2) Call DIFLOW to determine $A(|P_\Delta|)$ for the scheme;
- (3) Set up the discretized coefficients denoted by
 $AIP(I, J), AIM(I, J), AJM(i, j), AJP(i, j), AP(i, j)$
 $CON(i, j) \rightarrow a_P, a_W, a_E, a_N, a_S$ and b in the lecture
- (4) Call SOLVE to solve algebraic equations;
- (5) Update indicator: $ITER = ITER + 1$.

12 . GAMSOR

(1) Determine Γ_ϕ for different variables:

$$u, v - \mu(\text{or } \eta) ; T - \lambda$$

(2) Store source terms S_P, S_C of different variables into correspondent $AP(i, j), CON(i, j)$, respectively.

(3) Set up additional source terms for those boundary CVs with 2nd or 3rd condition, $S_{c,ad}, S_{p,ad}$, and add them to original source terms, $CON(i, j), AP(i, j)$ respectively, by accumulated way (累加) :

$$\begin{array}{l}
 CON(I, J) \leftarrow \boxed{\text{Original data}} + \underset{S_{c,ad}}{CON(I, J)} \\
 AP(I, J) \leftarrow \boxed{\text{Original data}} + \underset{S_{p,ad}}{AP(I, J)}
 \end{array}$$

13 . DIFLOW

Determine $A(|P_{\Delta}|)$ based on D and F.

14 . SOLVE

Adopt ADI line iteration + block correction to solve algebraic equations; Inner iteration is controlled by FORTRAN variable **NTIMES(NF)** , usually within 1 to 6; Outer iteration is controlled by indicator ITER, which may reach $10^3 - 10^5$, depending on cases.

8.3.4 Functions and limitations if the code

Three functions (功能):

- (1) It can solve the incompressible fluid flow and heat transfer problems in three two-dimensional orthogonal coordinates;
- (2) It can solve 10 dependent variables consecutively and print out 14 variables consecutively(连续地) ;
- (3) It can solve both dimensional and dimensionless governing equations.

Limitations (限制)

- (1) It is **not convenient** to simulate transient problems with high non-linearity;
- (2) It is **not convenient** to simulate problems with irregular domain;
- (3) It **can not** simulate compressible fluid flow.

Chapter 8 General Code for 2D Elliptical Fluid Flow and Heat Transfer Problems

8.1 Format Improvement of General Governing
Equation

8.2 Numerical Methods Adopted and Discretization
Equations

8.3 Code Structure and Module Functions

8.4 Grid System

8.5 Techniques Adopted in the Code

8.6 Methods of application and explanation of
MAIN Program

8. 4 Grid System

8.4.1 Regulations for three coordinates

8.4.2 Numbering system for geometric parameters and variables

8.4.3 Composite picture of coordinates

8.4.4 Explanations of pressure field simulation

8. 4 Grid System

8.4.1 Regulations for three coordinates

1. Cartesian coordinate

- (1) $MODE = 1$;
- (2) Unit thickness in Z-direction;
- (3) Origin of the coordinate locates in the left-bottom position.

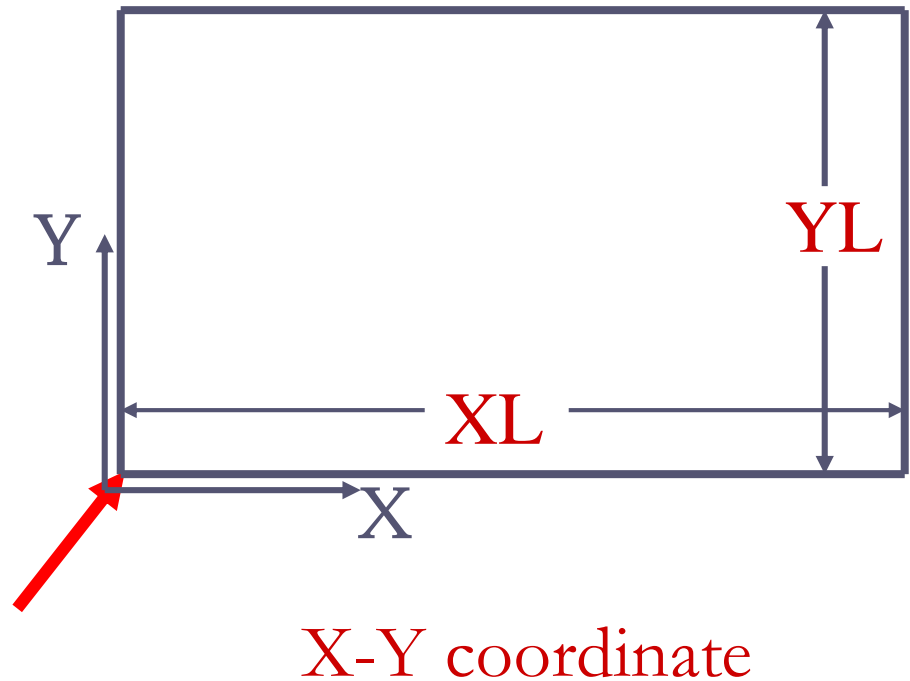

2. Symmetric cylindrical coordinate

- (1) MODE=2;
- (2) Simulation is conducted for $\Delta\theta = 1$ radian (弧度);
- (3) R(J) starts from symmetric axis
- (4) R (1) should be given.

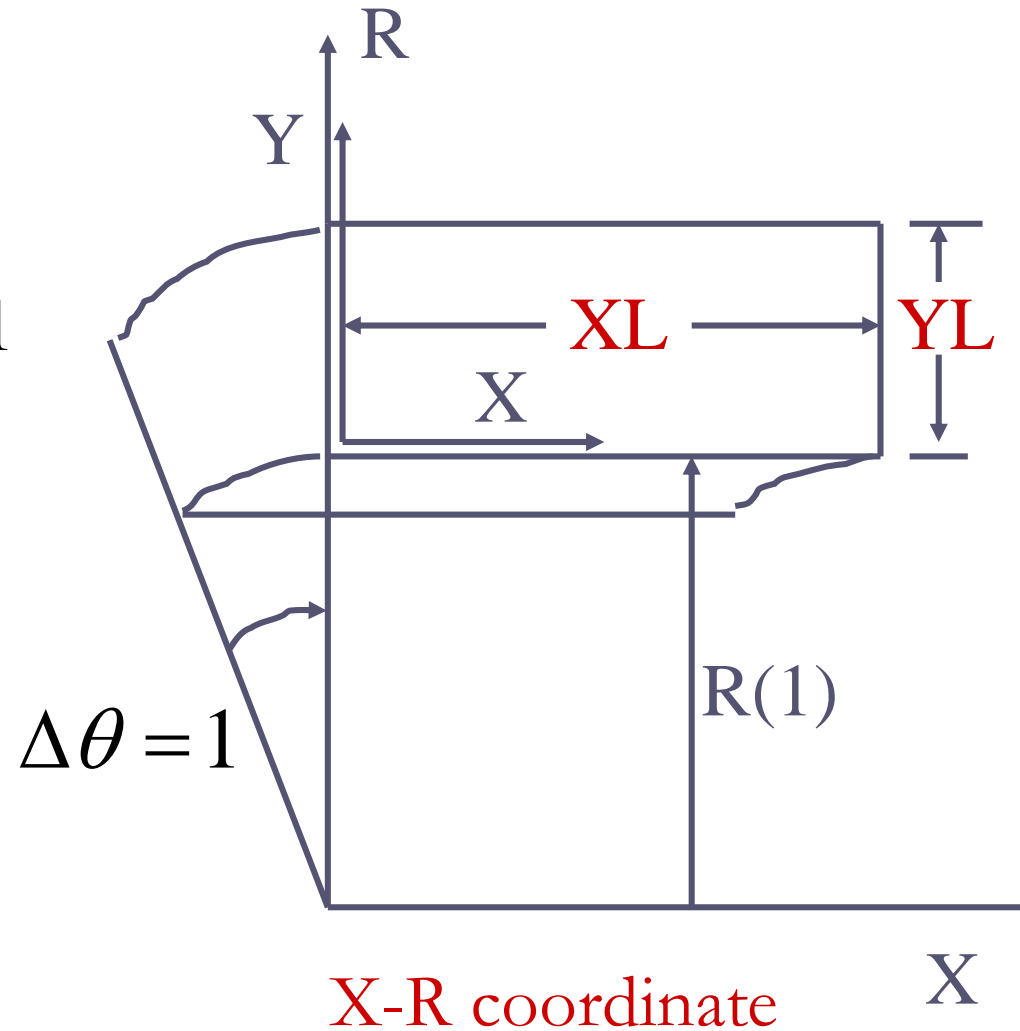

3. Polar coordinate

- (1) MODE = 3;
- (2) Unit thickness in Z direction;
- (3) R(J) starts from circle center;
- (4) R(1) should be given;
- (5) Angle θ should be less than 2π

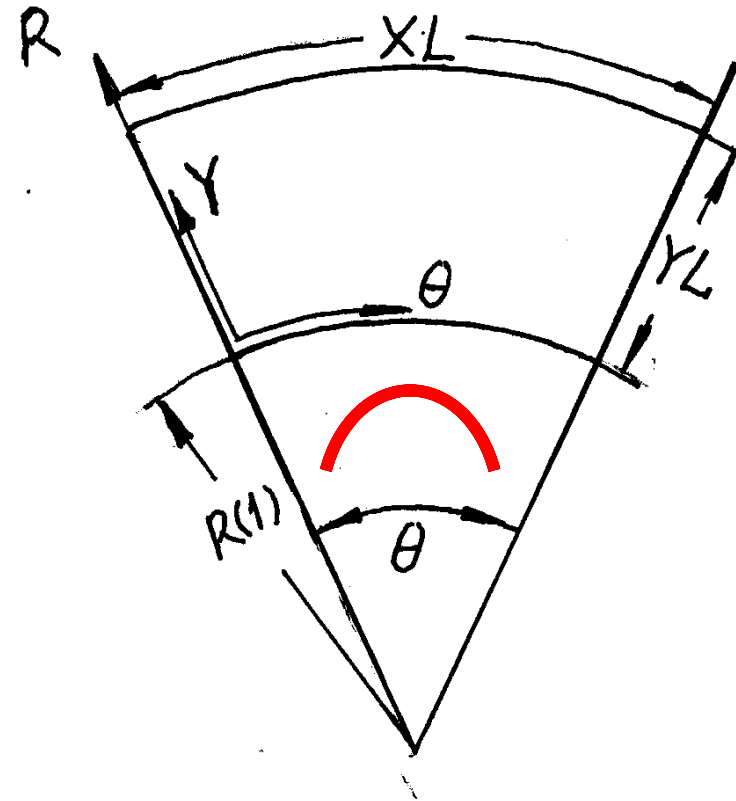

Theta-R coordinate

8.4.2 Numbering system for geometric parameters and variables

1. Interfaces of main CV : $XU(i), i=2, \dots, L1,$
 $YV(j), j=2, \dots, M1$

2. Main nodes : Last three nodes in X-direction: L1, L2, L3; in Y-direction: M1, M2, M3

3. Width of main CV : $XCV(i), i = 2, \dots, L2;$
 $YCV(j), j=2, \dots, M2$

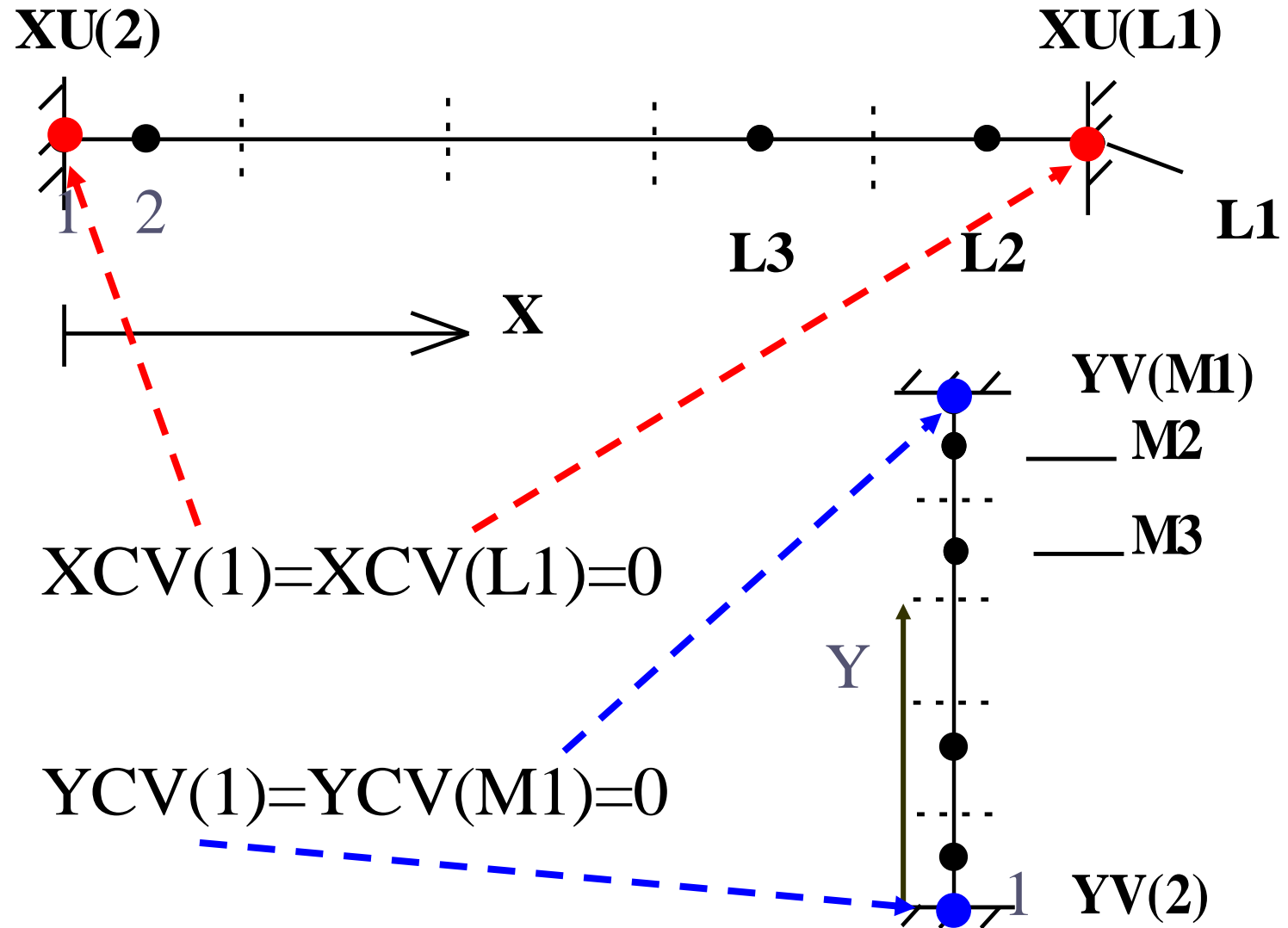

4. Distances between nodes:

$$\mathbf{XDIF}(i) = \mathbf{X}(i) - \mathbf{X}(i-1), \quad i = 2, \dots, L1$$

$$\mathbf{YDIF}(j) = \mathbf{Y}(j) - \mathbf{Y}(j-1), \quad j = 2, \dots, M1$$

5. Widths of velocity CVs :

$$\mathbf{XCVS}(i), \quad i=3, \dots, L2;$$

$$\mathbf{YCVS}(j), \quad j=3, \dots, M2$$

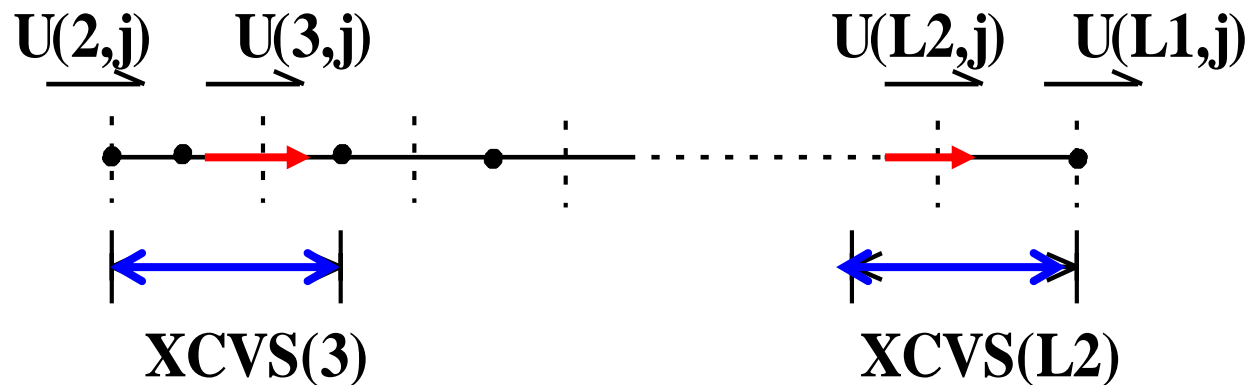

6. Velocity numbering: the node number towards which the velocity arrow directs is the number of velocity

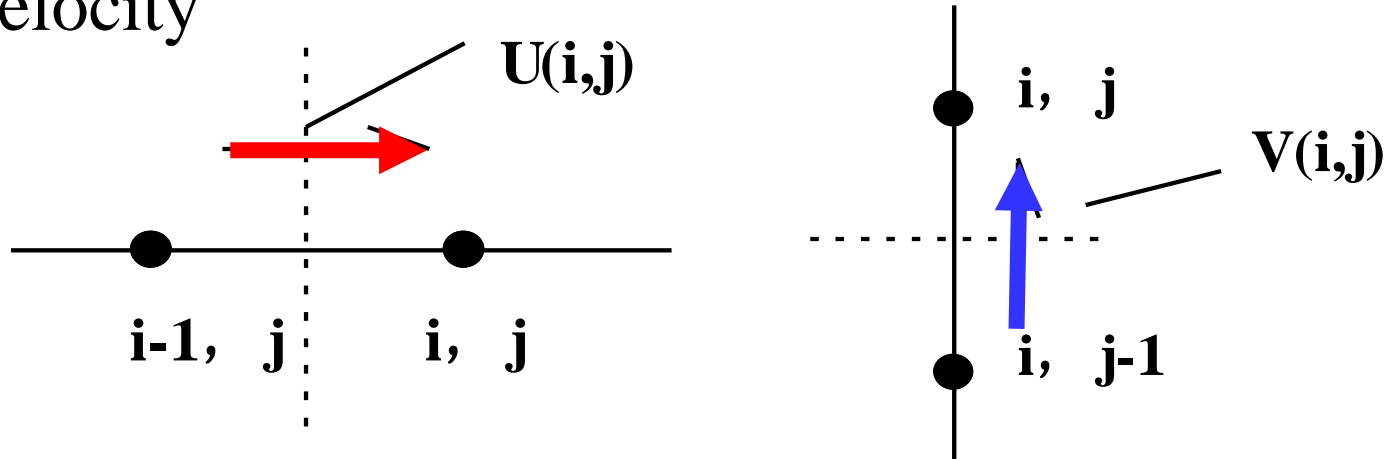

7. Starting points of solution region of ABEqs.

Because all boundaries are treated as 1st kind, solution is conducted within the inner region; the starting nodes of solutions for u, v, p are different, denoted in the code by FORTRAN variables IST, JST.

IST, JST represent the number of starting node in
X, Y iteration:

Variable	IST	JST
ϕ, p, p'	2	2
u	3	2
v	2	3

8.4.3 Composite picture of coordinates

Composite figure in X-direction

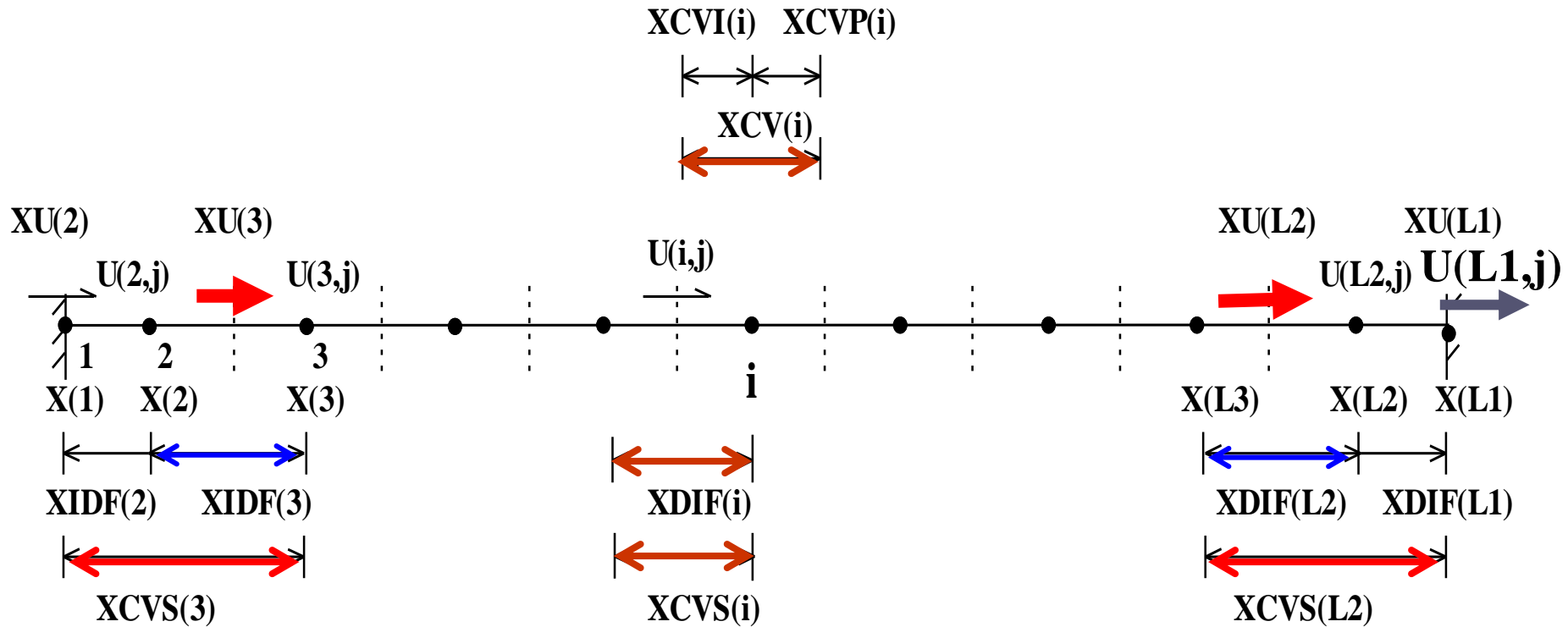

Similarly in Y-direction.

8.4.4 Explanations of pressure field simulation

1. The boundary pressure is **extrapolated** after obtaining converged solutions.

2. Pressure difference for $u(3,j)$ during iteration:

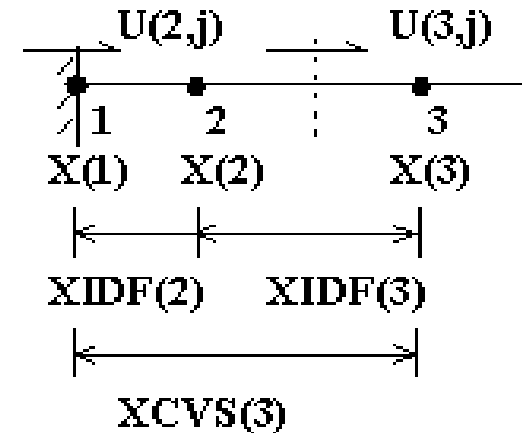

For $u(3,j)$ its width is $XCV(3)$ and pressure difference $[p(3,j)-p(1,j)]$ should be used in momentum equation; However, $p(1,j)$ is not known during iteration, following method is used to overcome the difficulty: **using a magnified area to compensate reduced pressure difference:**

$$\left[\frac{VOL(3, j)}{XDIF(3)} \right] (p(2, j) - p(3, j))$$

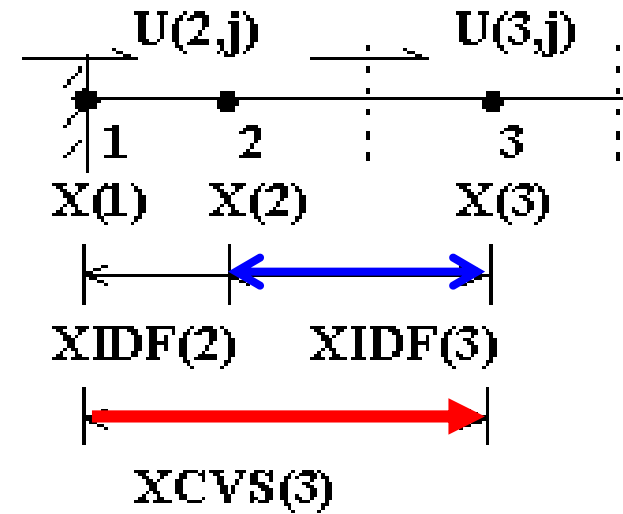

In the inner region, $XCVS(i)=XDIF(i)$, hence $VOL(i,j)/XDIF(i)$ equals the area where pressure acts; While near the boundary $XDIF(3)$ is less than $XCVS(3)$. Thus this treatment is equivalent to linear interpolate , from $[p(2,j)-p(3,j)]$ to get $[p(1,j)-p(3,j)]$:

$$p(1, j) - p(3, j) \cong (p(2, j) - p(3, j)) \left[\frac{XCVS(3)}{XDIF(3)} \right]$$

3. Pressures at four corners are not used during simulation; However for output requirement they are calculated as follows:

$$p(1,1) + p(2,2) = p(1,2) + p(2,1) \rightarrow$$

$$p(1,1) = p(2,1) + p(1,2) - p(2,2)$$

4. For incompressible flow, pressure value is relative to some reference; **For output purpose a reference point is specified by (IPREF,JPREF) :**

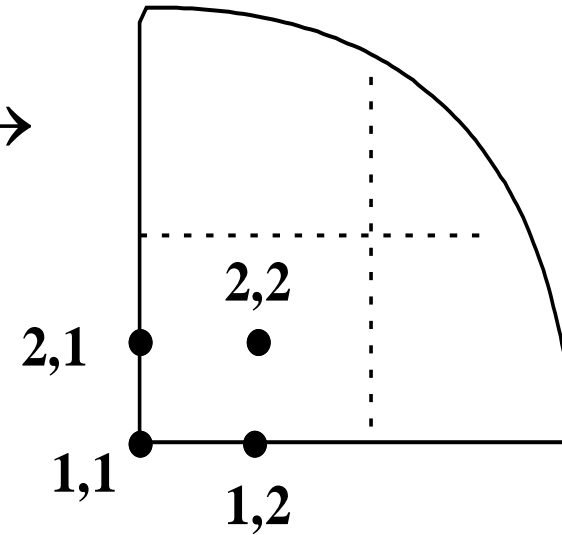

Interpolation for
Corner pressure
角点压力的插值

$$p(i, j) = p(i, j) - p(IPREF, JPREF)$$

In the code, the default values are 1 for both IPREF and JPREF.

8. 5 Techniques Adopted in the Code

8.5.1 Ten dependent variables can be solved and 14 variables can be printed out

8.5.2 Iteration for nonlinear steady problem is treated the same as marching process of linear unsteady problem

8.5.3 Methods for saving memories

8.5.4 Methods for saving computational times

8. 5 Techniques Adopted in the Code

8.5.1 Ten dependent variables can be solved and 14 variables can be printed out

1. Define a simple variable NF , its maximum value is 10 ($NFMAX$); NF from 1 to 4 represents u, v, p and T , respectively; $NF \geq 5$ can represent other variables defined by user.
2. Define a 3-D array $F(NI, NJ, NFX4)$, $NFX4=14$;
 p , Rho , $Gamma$, and c_p are defined as the 11th, 12th, 13th, and 14th variable, respectively.

3. Define two logic arrays : LSOLVE(NF) and LPRINT(NF), and their default values are .FALSE.; In USER if the value of LSOLVE(NF), say for $NF=1$, is set as .T., then in SETUP 2 this variable is solved.

4. In SETUP2, Visit NF from 1 to NFMAX in order; When some value of NF is visited and LSOLVE(NF)=.T., then this variable is solved; Similarly in PRINT SUBROUTINE NF is visited form 1 to NFX4(=14) in order, as long as LPRINT(NF)=.T., the variable is printed out.

8.5.2 Iteration for **nonlinear steady problem** is treated the same as marching process of **linear unsteady** problem

Finishing iteration of one level for steady problem ($ITER=ITER+1$) is equivalent to one time step forward for unsteady problem ($T=T+DT$).

In order to guarantee the convergence of iteration for solving ABEqs., several cycles are included in one level iteration with cycle number being adjustable.

1. $ITER+1$ implies finishing one level iteration, which is equivalent to $T=T+DT$, forward one time step.

2. Set up an array, $NTIMES(NF)$, for indicating cycle number in one iteration. Its default value is one. If $NTIMES(2)=4$, then the algebraic equations of the second variable ($NF=2$) will be iteratively solved by four cycles. In SOLVE , $NTIMES(NF)$ serves as the upper limit for do-loop: $NT=1, NTIMES(NF)$.

3. Every cycle includes 6 solution practices:

In X, Y-direction two block corrections;

In X-direction back-and forth (来回) line iterations;

In Y-direction, back-and forth line iterations .

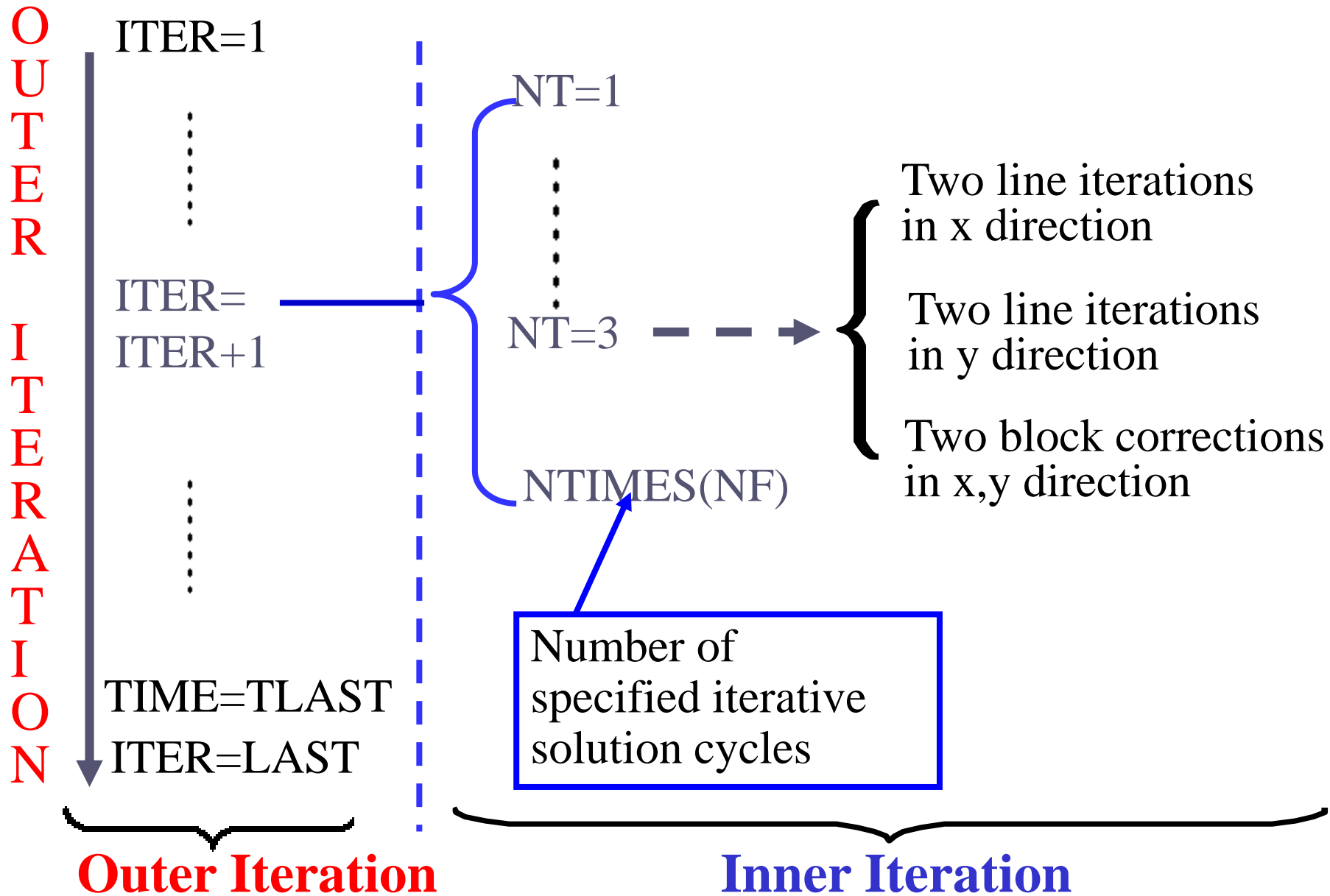

4. Principles for selecting value of NTIMES(NF)

(1) Steady and nonlinear problems:

NTIMES(NF) takes values of $1 \sim 2$, because the coefficients are to be further updated;

(2) Unsteady and linear problems:

NTIMES(NF) may take a larger value, say $4 \sim 5$, to ensure that for every level iteration the solution of algebraic equations are converged.

The present code is not recommended to apply for solving **unsteady and nonlinear** problems: For such problem the coefficients within one time step should be updated, while in the present code within one time step coefficients remain unchanged. Then the time step has to be small enough.

8.5.3 Methods for saving memories

1. **Adopt one set of arrays:** AIP, AIM, AJP, AJM, CON, AP to store the coefficients of different dependent variables; Because of non-linearity coefficients of each variables are to be updated, there is no need to save them.

2. **Effective usage of array CON(i,j) and AP(i,j):**

(1) In GAMSOR they are used to store S_c , S_p , $S_{c,ad}$,

$S_{p,ad}$;

(2) In SETUP they are used to store b and a_p in the way of accumulated addition

$$a_p = \sum a_{nb} + a_p^0 - S_p \Delta V \quad b = S_c \Delta V + a_p^0 \phi_p^0$$

3. Adopt multiple inlet statement ENTRY

Function of **ENTRY**:

All **ENTRYS** within the same subroutine can share all **MODULE** located in the beginning part of the subroutine, and each **ENTRY** can be called individually.

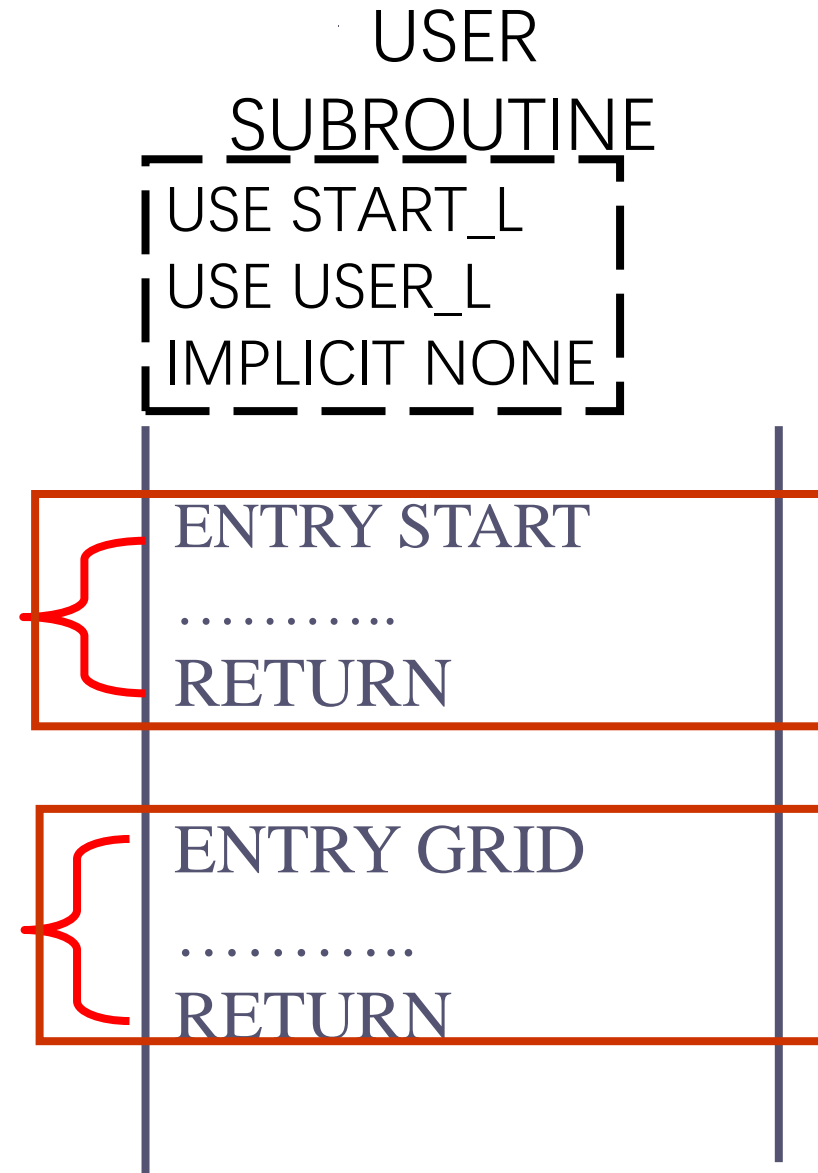

4. A compromise is made between memory and computational time

All one dimensional geometric parameters have their own individual array, totally 23 arrays, including $x(i)$ and $y(j)$;

All two dimensional parameters, including $\Delta V(i, j)$ are not stored: when needed they are temporary calculated and then they are deleted, rather than stored.

For 2D case, when node numbers in x,y direction are as large as $L1=M1=40$, then the memory of one 2-D array is equivalent to 40 1-D arrays.

Volume calculation of 3 CVs of cylindrical coordinate:

$$VOL = XCV(i) * YCV(j) * R(j) = XCV(i) * \underline{YCVR(j)}$$

Area normal to flow direction

Main CV:

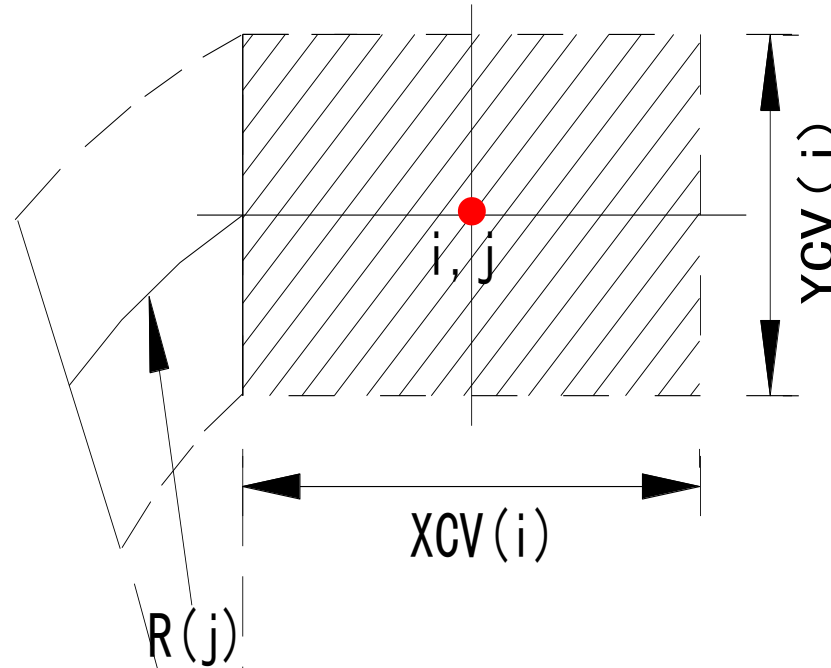

Symmetric cylindrical coordinate

u-CV:

$$VOL = XCVS(i) * \underline{YCV(j)} * R(j) = XCVS(i) * \underline{YCVR(j)}$$

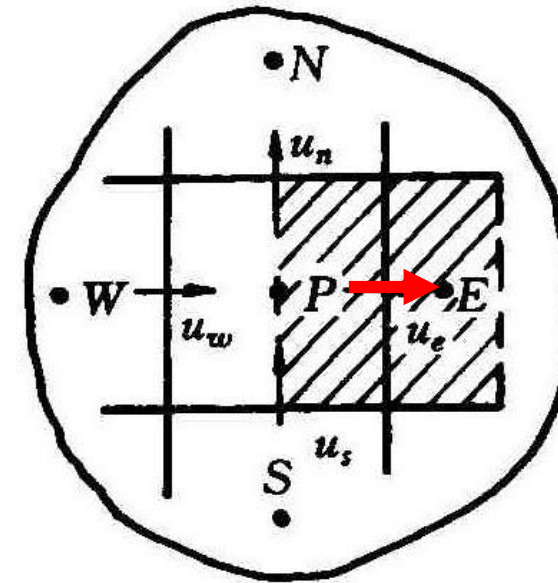
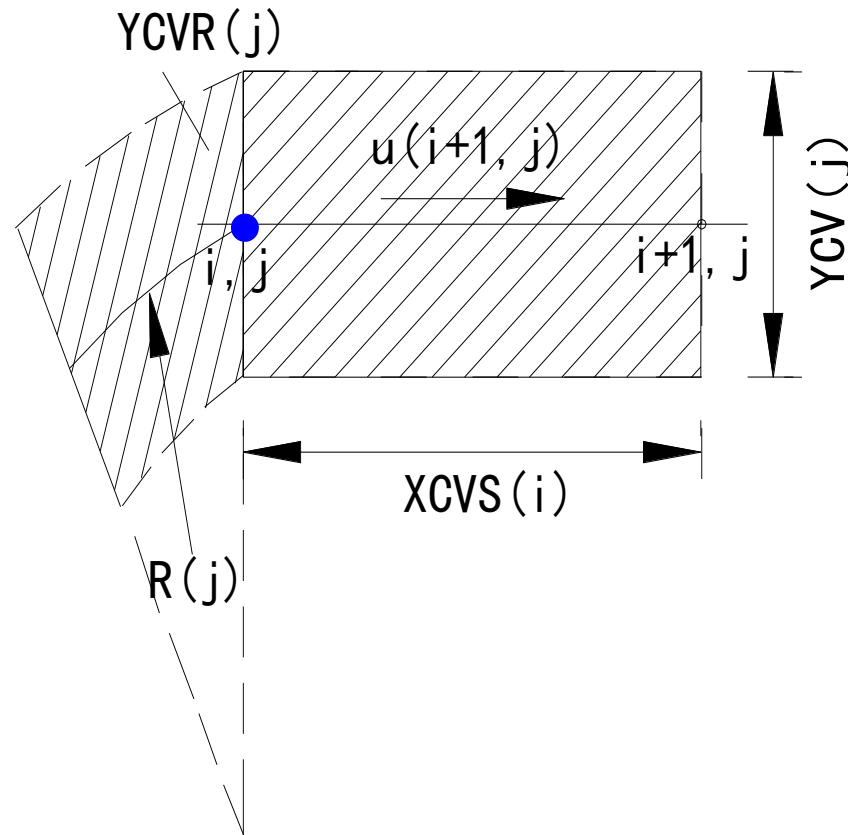

Symmetric cylindrical coordinate, u-CV

v-CV:

$$VOL = XCV(i) * \underbrace{YDIF(j) * \frac{R(j) + R(j-1)}{2}}_{YCVRS(j)} = XCV(i) * \underbrace{YCVRS(j)}$$

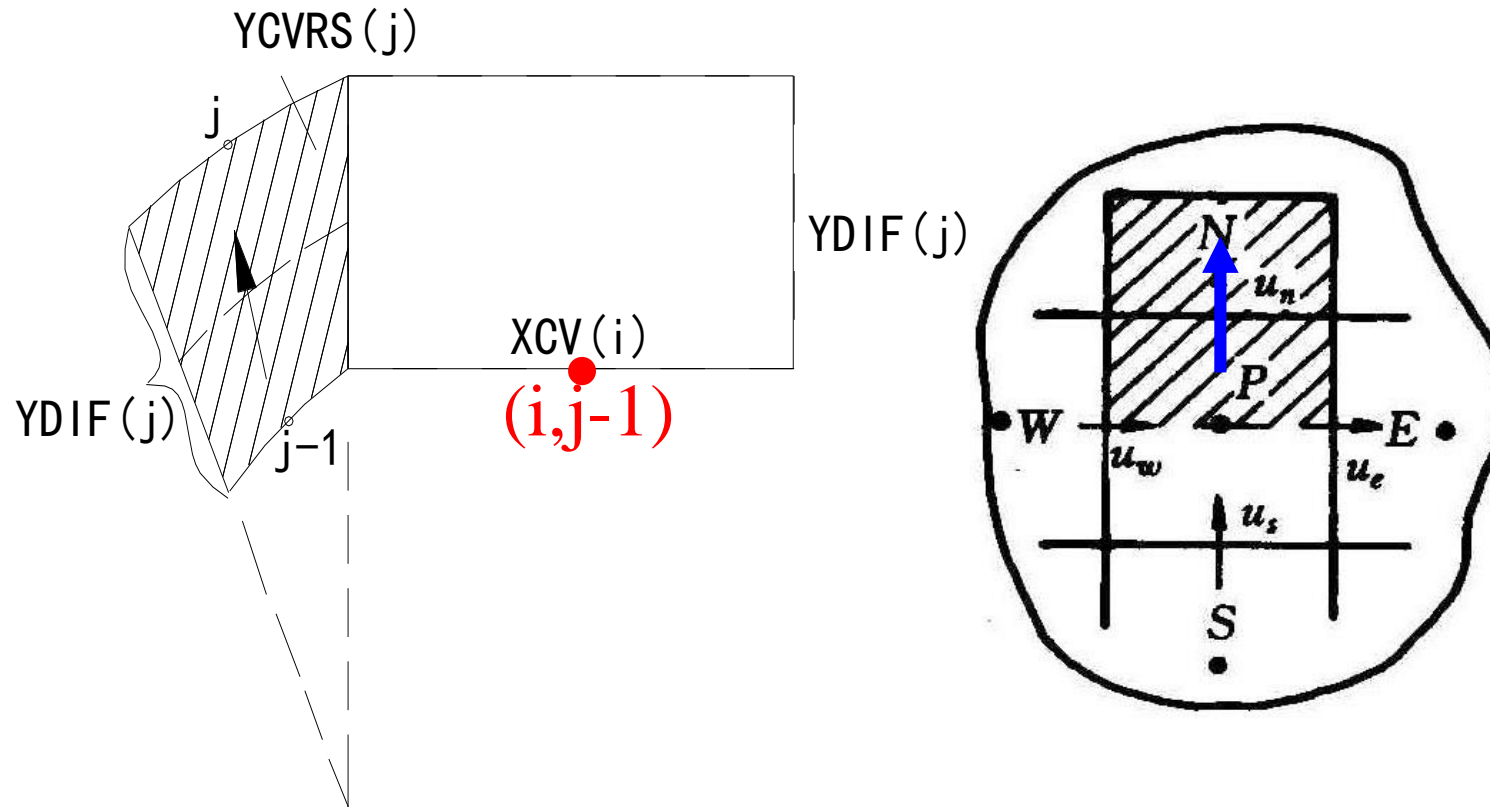

Symmetric cylindrical coordinate, v-CV

5. Terminate non-linearity iteration by specifying **LAST**, rather than by comparison of two subsequent iterations, thus saving one 3-D array. However, the appropriate value of **LAST** should be determined during iteration.

8.5.4 Methods for saving computational times

1. Data transfer between different units of the code by using **MODULE**. It is the most efficient way for data transfer.

2. Take advantage of relationship between coefficients, saving computational time .

It has been shown that for the five 3-point schemes:

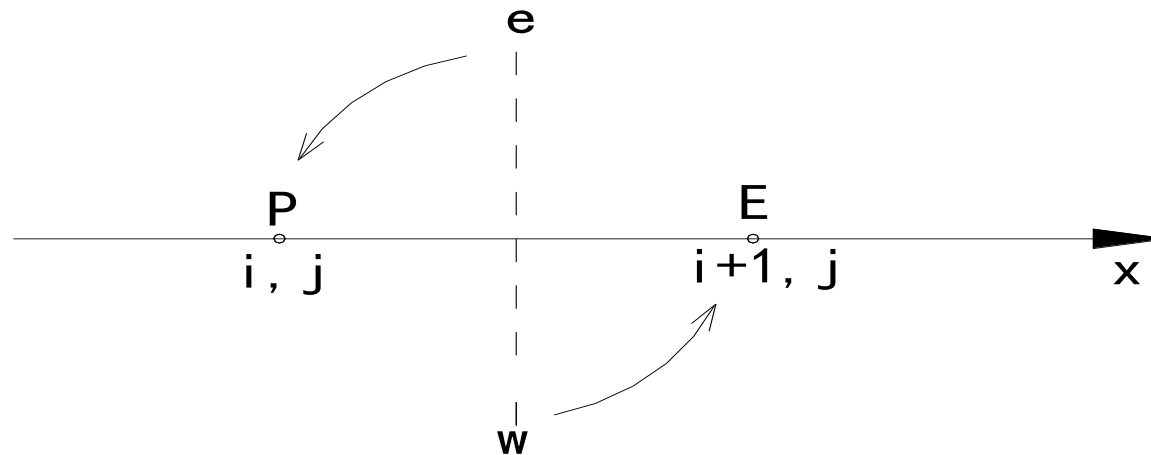

$$a_E(i, j) = D_e A(|P_{\Delta e}|) + [|-F_e, 0|]$$

$$a_W(i+1, j) = D_w A(|P_{\Delta w}|) + [|F_w, 0|]$$

$$a_W(i+1, j) - a_E(i, j) = [|F_w, 0|] - [|-F_e, 0|] = \underline{F_e}$$

Thus $a_E(i, j)$ can be easily obtained from $a_W(i+1, j)$

$$a_E(i, j) = a_W(i+1, j) - FLOW$$

Similarly:

$$a_N(i, j) = a_S(i, j+1) - FLOW$$

3. Time saving during ADI-line iteration))

When scanning from bottom to top along y , $J=2$ to $M2$; then back scanning can start from $M3$ rather than from $M2$, because the line of $M2$ is just solved in the upward scanning and all the coefficients and constants in that line remain unchanged.

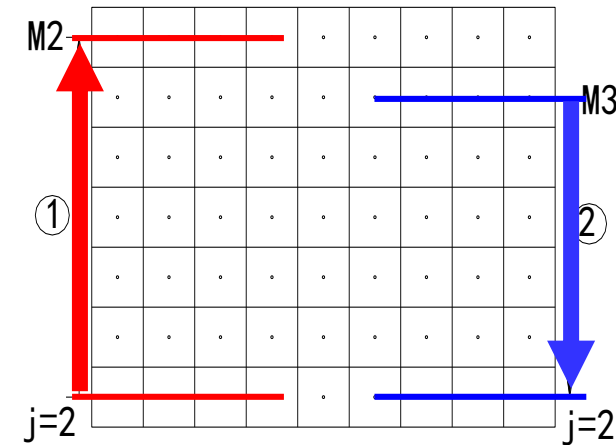

Coefficients are not changed during one level iteration, the key is the constant term b : for the line $M2$ in the upward scanning:

$$b = b' + a_N \Phi_{given}(i, M1) + a_S \Phi^*(i, M3)$$

In the downward scanning the b term of line $M2$ does not change, while for the line $M3$ b -term has been changed after the solution of line $M2$:

$$b = b' + a_N \Phi^*(i, M2) + a_S \Phi^*(i, M3 - 1)$$

In the downward scanning $\Phi^*(i, M2)$ has been updated during upward scanning. Hence this line should be solved.

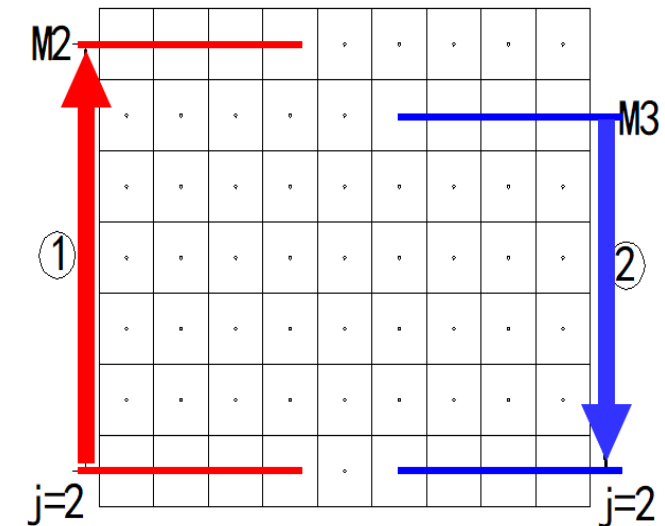

本组网页地址: <http://nht.xjtu.edu.cn> 欢迎访问!
Teaching PPT will be loaded on ou website



同舟共济
渡彼岸!

People in the
same boat help
each other to
cross to the other
bank, where....