

Numerical Heat Transfer (数值传热学) Chapter 1 Introduction



Instructor Tao, Wen-Quan

**Key Laboratory of Thermo-Fluid Science & Engineering
Int. Joint Research Laboratory of Thermal Science & Engineering
Xi'an Jiaotong University
Innovative Harbor of West China, Xian
2021-Sept-26**

Brief Introduction to Course

1. Textbook – 《数值传热学》，2nd ed., 2001

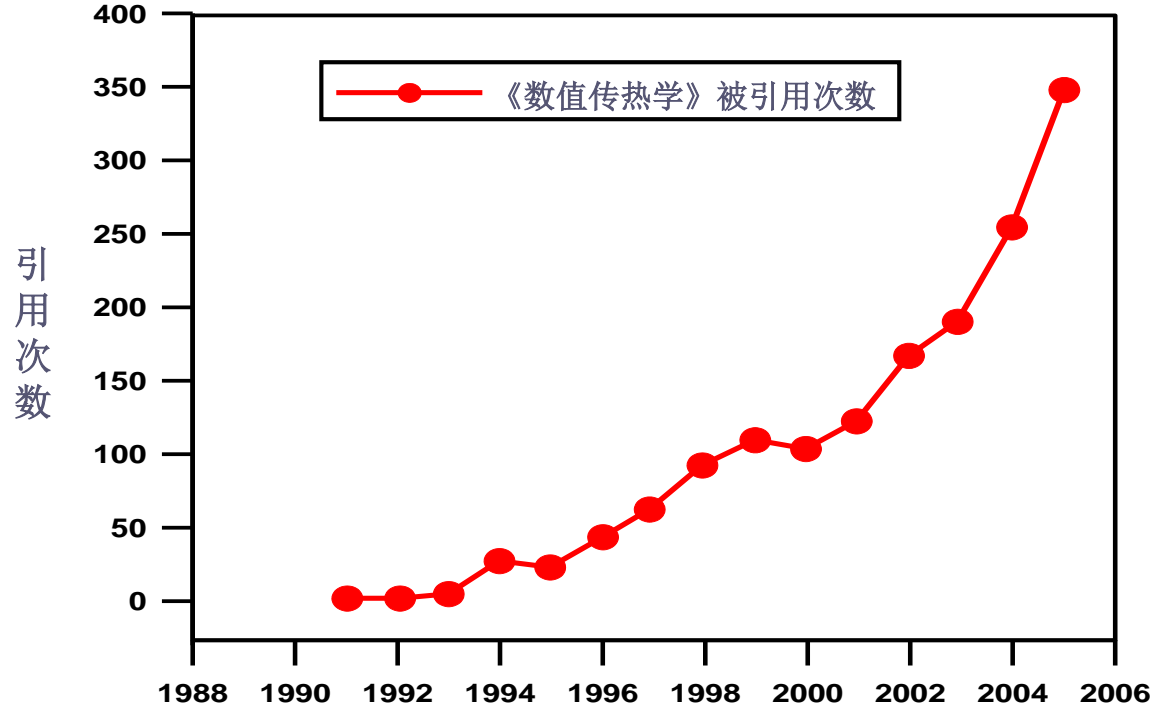
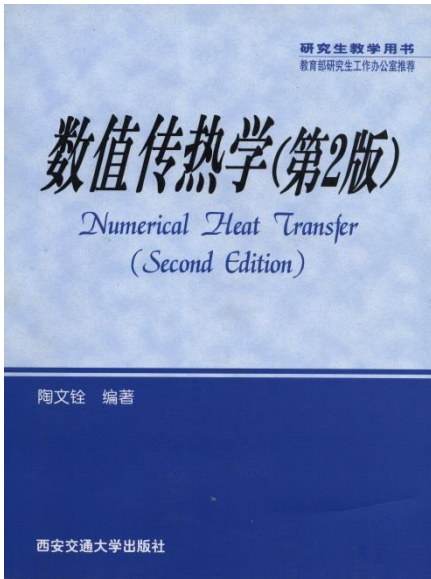

《数值传热学》 Citations of the textbook

The total citation times home and abroad(国内外)>15000

2. Relative International Journal 有关的主要国外期刊

1. Numerical Heat Transfer, Part A- Applications; Part B- Fundamentals

2. International Journal of Numerical Methods in Heat and Fluid Flow

3. International Journal of Numerical Methods in Fluids.

4. Computer & Fluids

5. Progress in Computational Fluid Dynamics

6. Journal of Computational Physics

5. International Journal of Numerical Methods in Engineering

7. Computer Methods of Applied Mechanics and Engineering

8. Engineering Computations

10. Computer Modeling in Engineering & Sciences (CMES)

11. ASME Journal of Heat Transfer
12. International Journal of Heat and Mass Transfer
13. ASME Journal of Fluids Engineering
14. International Journal of Heat and Fluid Flow
15. AIAA Journal

3. Teaching hours – 44 hrs-basic principles, including teaching code ; 12 hrs-FLUENT software

4. Course score (课程成绩) – Home work/Computer-aided project: –50/50

5. Methodology – Open, Participation and Application (开放, 参与, 应用)

6. Teaching assistants group

冯相友(Xiangyou FENG);

力乙刚(Yigang LI)

李泽希(Zhexi LI);

吴天宇(Tianyu WU)

王子星(Zixing WANG) *;

崔琼瑶(Qiongyao CHUI)

黄 昆(Kun HUANG);

程 想(Xiang Chen)

夏 阳(Yang XIA);

郭凌焱 (Lingyi GUO)

7. Teachers' group for NHT



陶文铨
(W.Q.Tao)



陈黎
(Li Chen)

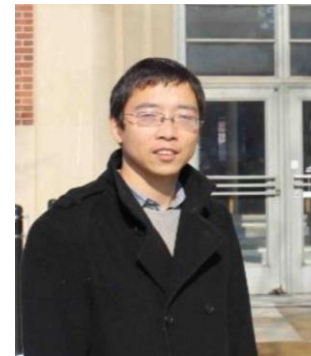

冀文涛
(Wen-Tao Ji)



任秦龙
(Qing-Long Ren)

8. We Chat Group

2020 《数值传热学》教学群

To join the group
copy QR code(二维码) :

**Every student of this class
should be in the group!**

2021数值传热学-兴庆校区
通知群



该二维码7天内(9月17日前)有效, 重新进入将更新

星
陕西 西安



扫一扫上面的二维码图案, 加我微信

9. Methods for improving teaching and studying

- 1) Speaking simple but clear English with Chinese note (注释) of new terminology (术语) and some difficult words---**teacher's side**;
- 2) Repeating very important contents by Chinese (with exactly same contents of English) to enhance (加强) students' understanding (理解)---- **teacher 's side**;
- 3) Indicating the part of the text book corresponding to the contents talked in the class---- **teacher 's side**;
- 4) Showing the part of the text book for students to preview which will be talked next time---- **teacher 's side**;

- 5) Offering office-hours (答疑时间) in the evening of every Wednesday;----**teachers' sides**;
- 6) Offering after-class instruction(课后辅导) for some special parts of the teaching contents apart from the normal office-hours (答疑时间);----**teachers' sides**;
- 7) Enhancing communications between students and teachers thru a We Chat-group ;Our 10 assistants will help in this regard----**both sides**;
- 8) Previewing (预习) PPT of 2020 loaded in our group; website: <http://nht.xjtu.edu.cn>----**students' side**.
- 9) Previewing (预习) that part of the text book indicated by the teacher----**students' side**.

Contents of Chapter 1

1.1 Mathematical formulation (数学描述) of heat transfer and fluid flow (HT & FF) problems

1.2 Basic concepts of NHT, its importance and application examples

1.3 Mathematical and physical classification of HT & FF problems and its effects on numerical solution

1.1 Mathematical formulation of heat transfer and fluid flow (HT & FF) problems

1.1.1 Governing equations (控制方程) and their general form

1. Mass conservation

2. Momentum conservation

3. Energy conservation

4. General form

1.1.2 Conditions for unique solution (唯一解)

1.1.3 Example of mathematical formulation

1.1 Mathematical formulation of heat transfer and fluid flow (HT & FF) problems

All macro-scale (宏观) HT & FF problems are governed by three conservation laws: mass, momentum and energy **conservation law (守恒定律)**.

The differences between different problems are in: **conditions for the unique solution (唯一解)**: initial (初始的) & boundary conditions, physical properties and source terms.

1.1.1 Governing equations and their general form

1. Mass conservation

$$\frac{\partial \rho}{\partial t} + \frac{\partial(\rho u)}{\partial x} + \frac{\partial(\rho v)}{\partial y} + \frac{\partial(\rho w)}{\partial z} = 0$$

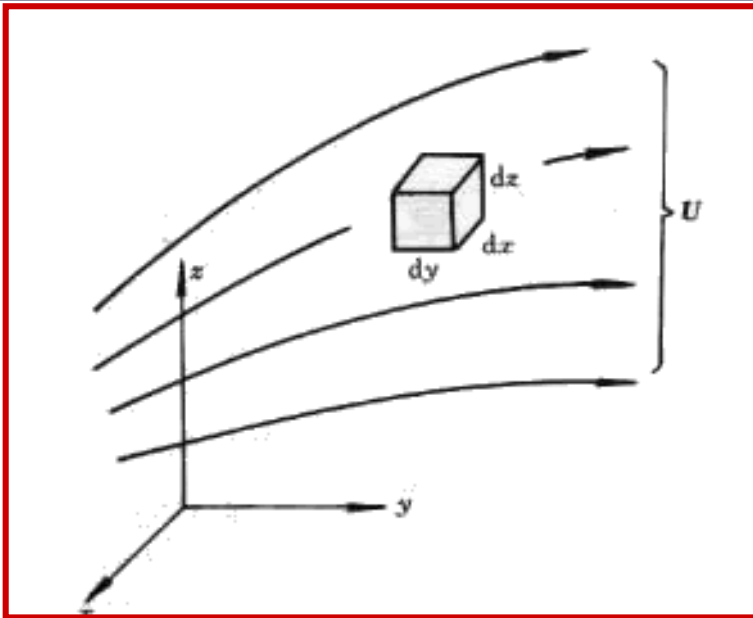

“*div*” is the mathematical symbol for divergence (散度) .

$$\frac{\partial \rho}{\partial t} + \text{div}(\rho \vec{U}) = 0$$

$$\text{div}(\rho \vec{U}) = \frac{\partial(\rho u)}{\partial x} + \frac{\partial(\rho v)}{\partial y} + \frac{\partial(\rho w)}{\partial z}$$

For incompressible fluid (不可压缩流体) :

$$\text{div}(\vec{U}) = 0$$

$$\frac{\partial u}{\partial x} + \frac{\partial v}{\partial y} + \frac{\partial w}{\partial z} = 0$$

flow without source and sink (没有源与汇的流动)。

2. Momentum conservation

Applying the 2nd law of Newton ($F=ma$) to the elemental control volume (控制容积) in the three-dimensional coordinates:

**[Increasing rate of momentum of the CV]=
[Summation of external (外部) forces
applying on the CV]+ Net inflow of
momentum**

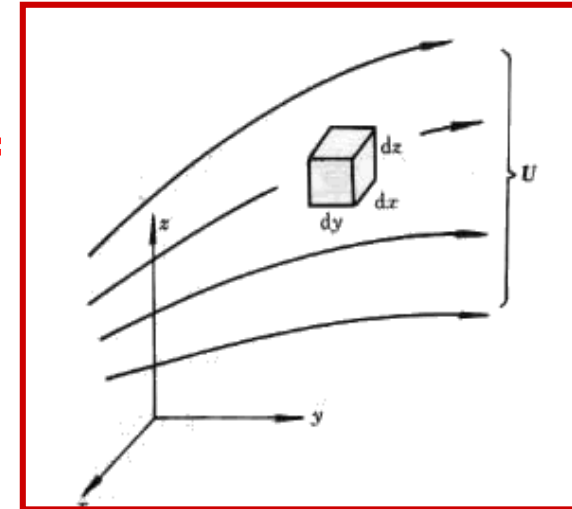

Adopting Stokes assumption: stress is linearly proportional to strain(应力与应变成线性关系), We have for component u in x -direction:

Source
term

$$\begin{aligned}
 \underbrace{\frac{\partial(\rho u)}{\partial t}}_{\text{Transient term}} + \underbrace{\frac{\partial(\rho uu)}{\partial x} + \frac{\partial(\rho uv)}{\partial y} + \frac{\partial(\rho uw)}{\partial z}}_{\text{Convection term}} = & \underbrace{-\frac{\partial p}{\partial x}}_{\text{Diffusion term}} + \underbrace{\frac{\partial}{\partial x} (\bar{\lambda} \text{div} \vec{U} + 2\eta \frac{\partial u}{\partial x})}_{\text{Diffusion term}} \\
 & + \underbrace{\frac{\partial}{\partial y} [\eta (\frac{\partial v}{\partial x} + \frac{\partial u}{\partial y})] + \frac{\partial}{\partial z} [\eta (\frac{\partial u}{\partial z} + \frac{\partial w}{\partial x})]}_{\text{Diffusion term}} + \underbrace{\rho F_x}_{\text{Source term}}
 \end{aligned}$$

η dynamic viscosity , $\bar{\lambda}$ fluid 2nd molecular viscosity.

For gas, $\bar{\lambda} = -\frac{2}{3}\eta$

It can be shown (see the notes) that the above equation can be reformulated as **(改写为)** following general form of Navier-Stokes equation for u component:

$$\frac{\partial(\rho u)}{\partial t} + \operatorname{div}(\rho u \vec{U}) = \operatorname{div}(\eta \operatorname{grad} u) + S_u$$

Transient term
非稳态项

Convection term
对流项

Diffusion term
扩散项

Source term
源项

u, v, w ----velocity components in three directions,
 dependent variable **(因变量)** to be solved;
 \vec{U} ----fluid velocity vector;
 S_u ----source term.

Source term in x-direction:

$$S_u = \frac{\partial}{\partial x} \left(\eta \frac{\partial u}{\partial x} \right) + \frac{\partial}{\partial y} \left(\eta \frac{\partial v}{\partial x} \right) + \frac{\partial}{\partial z} \left(\eta \frac{\partial w}{\partial x} \right) + \frac{\partial}{\partial x} (\bar{\lambda} \text{div} \vec{U}) + \rho F_x - \frac{\partial p}{\partial x}$$

Similarly:

$$S_v = \frac{\partial}{\partial x} \left(\eta \frac{\partial u}{\partial y} \right) + \frac{\partial}{\partial y} \left(\eta \frac{\partial v}{\partial y} \right) + \frac{\partial}{\partial z} \left(\eta \frac{\partial w}{\partial y} \right) + \frac{\partial}{\partial y} (\bar{\lambda} \text{div} \vec{U}) + \rho F_y - \frac{\partial p}{\partial y}$$

$$S_w = \frac{\partial}{\partial x} \left(\eta \frac{\partial u}{\partial z} \right) + \frac{\partial}{\partial y} \left(\eta \frac{\partial v}{\partial z} \right) + \frac{\partial}{\partial z} \left(\eta \frac{\partial w}{\partial z} \right) + \frac{\partial}{\partial z} (\bar{\lambda} \text{div} \vec{U}) + \rho F_z - \frac{\partial p}{\partial z}$$

For incompressible fluid with constant properties the source term does not contain velocity-related part.

3. Energy conservation

[Increasing rate of internal energy in the CV]= [Net heat going into the CV]+[Work conducted by body forces and surface forces]

Introducing Fourier's law of heat conduction and neglecting the work conducted by forces; Introducing enthalpy (焓) $h = c_p T$, assuming $c_p = \text{Constant}$,
 We have:

$$\frac{\partial(\rho T)}{\partial t} + \text{div}(\rho T \vec{U}) = \text{div}\left(\frac{\lambda}{c_p} \text{grad}(T)\right) + S_T$$

$$\text{grad}(T) = \frac{\partial T}{\partial x} \vec{i} + \frac{\partial T}{\partial y} \vec{j} + \frac{\partial T}{\partial z} \vec{k} \quad \frac{\lambda}{c_p} \rightarrow \frac{\lambda \eta}{c_p \eta} \rightarrow \left(\frac{\lambda}{c_p \eta}\right) \eta \rightarrow \frac{\eta}{\text{Pr}}$$

4. General form of the governing equations

$$\frac{\partial(\rho\phi)}{\partial t} + \text{div}(\rho\phi\vec{U}) = \text{div}(\Gamma_{\phi}^* \text{grad}(\phi)) + S_{\phi}^*$$

Transient

Convection

Diffusion

Source

The differences between different problems:

- (1) Different boundary and initial conditions;
- (2) Different nominal source (名义源项) terms;
- (3) Different physical properties (nominal diffusion coefficients, 名义扩散系数)

5. Some remarks (说明)

1. The derived transient 3D **Navier-Stokes** equations can be applied **for both laminar and turbulent flows**.

2. When a HT & FF problem is in conjunction with (**与... 有关**) mass transfer process, the component (**组份**) conservation equation should be included in the governing equations.

3. Although c_p is assumed constant, the above governing equation can also be applied to cases with weakly changed c_p (**比热略有变化**).

4. Radiative (**辐射**) heat transfer is governed by a differential-integral (**微分-积分**) equation, and its numerical solution will not be dealt with here.

1.1.2 Conditions for unique solution

1. Initial condition (初始条件) $t = 0, T = f(x, y, z)$

2. Boundary condition (边界条件)

(1) First kind (Dirichlet): $T_B = T_{given}$

(2) Second kind (Neumann): $q_B = -\lambda \left(\frac{\partial T}{\partial n} \right)_B = q_{given}$

(3) Third kind (Rubin): Specifying (规定) the relationship between boundary value and its first-order normal derivative:

$$-\lambda \left(\frac{\partial T}{\partial n} \right)_B = h(T_B - T_f)$$

3. Fluid thermo-physical properties and source term of the process.

3rd kind boundary conditions for both solid heat conduction and convective heat transfer problems

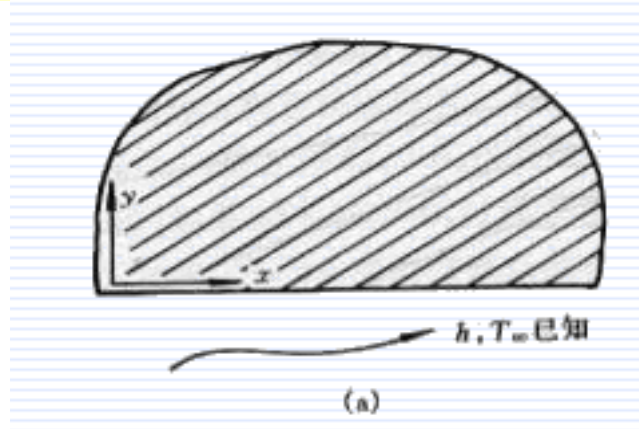

Heat conduction with 3rd kind B.C. at surface

h, T_{∞} are known

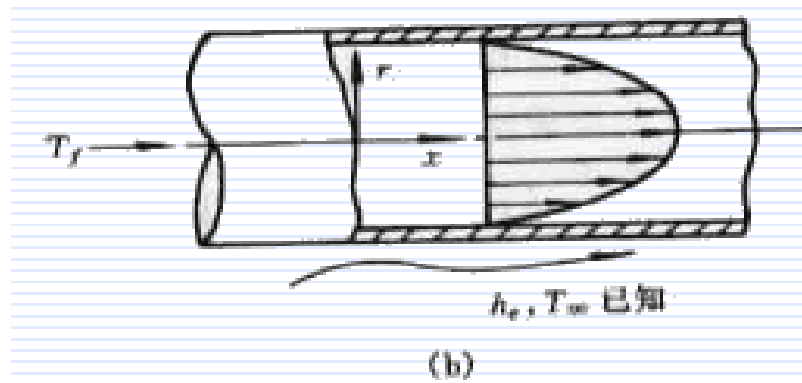

Inner convective heat transfer with 3rd kind condition at outer surface of tube wall

h_e, T_{∞} are known

For 3rd kind boundary condition heat flux is not known:

$$q = h(T_w - T_{\infty}) \text{ or } q = h(T_{\infty} - T_w)$$

1.1.3 Example of mathematical formulation

1. Problem and assumptions

Convective heat transfer in a sudden expansion region:
2D, steady-state, incompressible fluid, constant properties, neglecting gravity and viscous dissipation (粘性耗散) .

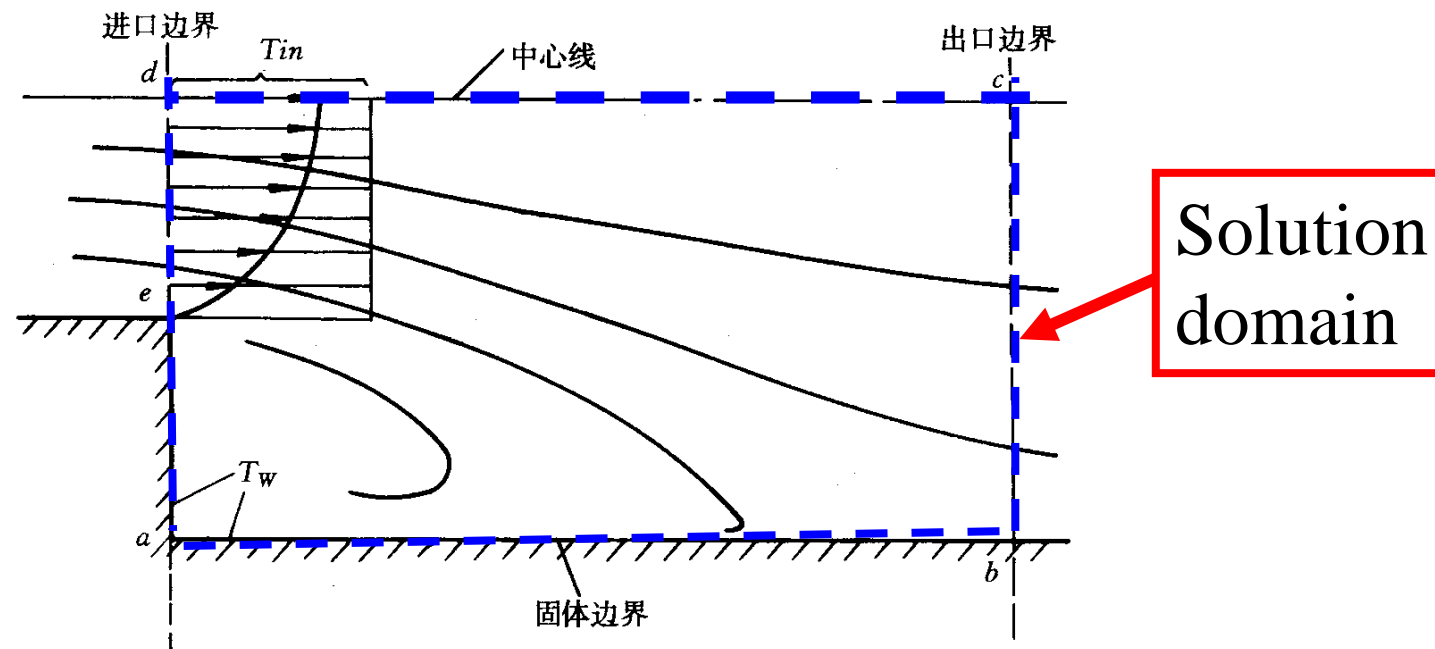

2. Governing equations

Complete set
of governing
equations

$$\frac{\partial u}{\partial x} + \frac{\partial v}{\partial y} = 0$$

$$\frac{\partial(uu)}{\partial x} + \frac{\partial(vu)}{\partial y} = -\frac{1}{\rho} \frac{\partial p}{\partial x} + \nu \left(\frac{\partial^2 u}{\partial x^2} + \frac{\partial^2 u}{\partial y^2} \right)$$

$$\frac{\partial(uv)}{\partial x} + \frac{\partial(vv)}{\partial y} = -\frac{1}{\rho} \frac{\partial p}{\partial y} + \nu \left(\frac{\partial^2 v}{\partial x^2} + \frac{\partial^2 v}{\partial y^2} \right)$$

$$\frac{\partial(uT)}{\partial x} + \frac{\partial(vT)}{\partial y} = a \left(\frac{\partial^2 T}{\partial x^2} + \frac{\partial^2 T}{\partial y^2} \right)$$

$$a = \frac{\lambda}{\rho c_p}$$

3. Boundary conditions

(1) **Inlet:** specifying (说明) variations of u, v, T with y ;

(3) **Center line:**

$$\frac{\partial u}{\partial y} = \frac{\partial T}{\partial y} = 0; \quad v = 0$$

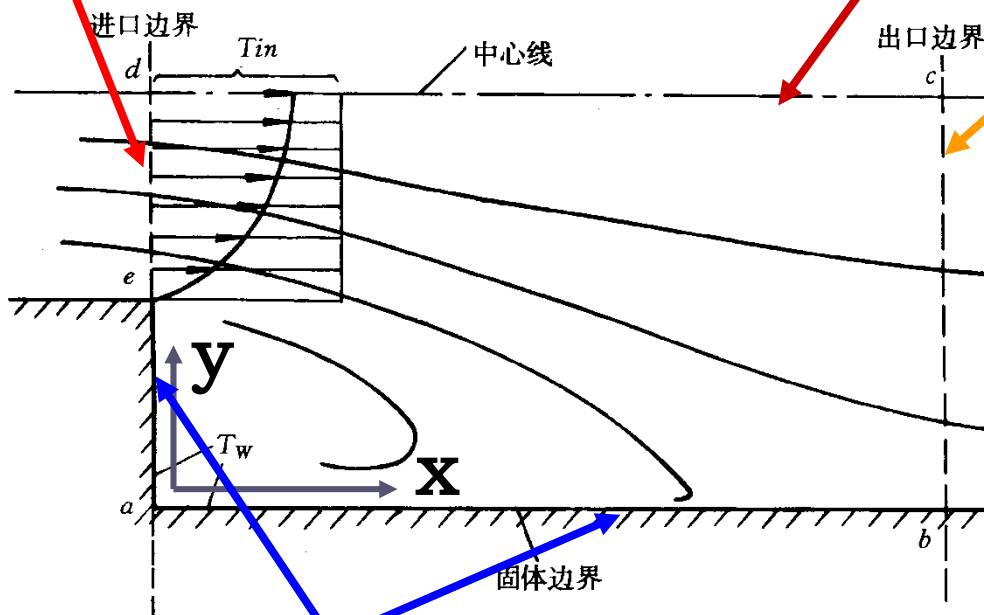

(4) **Outlet:** Mathematically the distributions of u, v, T or their first-order derivatives (导数) are required. Actually, approximations must be made.

(2) **Solid B.C.:** No slip (滑移) in velocity, no jump (跳跃) in temp.

Notes to Section 1.1

In the left hand side

$$\frac{\partial(\rho uu)}{\partial x} + \frac{\partial(\rho uv)}{\partial y} + \frac{\partial(\rho uw)}{\partial z} = \text{div}(\rho u \vec{U})$$

The right hand side :

$$\frac{\partial}{\partial x} (\bar{\lambda} \text{div} \vec{U} + 2\eta \frac{\partial u}{\partial x}) + \frac{\partial}{\partial y} [\eta (\frac{\partial v}{\partial x} + \frac{\partial u}{\partial y})] + \frac{\partial}{\partial z} [\eta (\frac{\partial u}{\partial z} + \frac{\partial w}{\partial x})] + \rho F_x - \frac{\partial p}{\partial x} =$$

$$\frac{\partial}{\partial x} (\eta \frac{\partial u}{\partial x}) + \frac{\partial}{\partial y} (\eta \frac{\partial u}{\partial y}) + \frac{\partial}{\partial z} (\eta \frac{\partial u}{\partial z}) + \frac{\partial}{\partial x} (\eta \frac{\partial u}{\partial x}) + \frac{\partial}{\partial y} (\eta \frac{\partial v}{\partial x}) + \frac{\partial}{\partial z} (\eta \frac{\partial w}{\partial x}) + \frac{\partial}{\partial x} (\bar{\lambda} \text{div} \vec{U})$$

$\text{div}(\text{grad}(u))$
 S_u

$$\rho F_x - \frac{\partial p}{\partial x} = \text{div}(\eta \text{grad} u) + S_u$$

$$\text{grad}(u) = \frac{\partial u}{\partial x} \mathbf{i} + \frac{\partial u}{\partial y} \mathbf{j} + \frac{\partial u}{\partial z} \mathbf{k}$$

$$\text{div}(\text{grad}(u)) = \frac{\partial}{\partial x} (\frac{\partial u}{\partial x}) + \frac{\partial}{\partial y} (\frac{\partial u}{\partial y}) + \frac{\partial}{\partial z} (\frac{\partial u}{\partial z})$$

Thus we have:

$$\frac{\partial(\rho u)}{\partial t} + \text{div}(\rho u \vec{U}) = \text{div}(\eta \text{grad} u) + S_u$$

Navier-Stokes

Gradient of a scalar (标量的梯度) is a vector:

$$\mathit{grad}(u) = \frac{\partial u}{\partial x} \vec{i} + \frac{\partial u}{\partial y} \vec{j} + \frac{\partial u}{\partial z} \vec{k}$$

Divergence of a vector (矢量的散度) is a scalar:

$$\mathit{div}(\mathit{grad}(u)) = \mathit{div}\left(\frac{\partial u}{\partial x} \vec{i} + \frac{\partial u}{\partial y} \vec{j} + \frac{\partial u}{\partial z} \vec{k}\right)$$

$$\mathit{div}(\mathit{grad}(u)) = \frac{\partial}{\partial x} \left(\frac{\partial u}{\partial x}\right) + \frac{\partial}{\partial y} \left(\frac{\partial u}{\partial y}\right) + \frac{\partial}{\partial z} \left(\frac{\partial u}{\partial z}\right)$$

$$\mathit{div}(\eta \mathit{grad}(u)) = \frac{\partial}{\partial x} \left(\eta \frac{\partial u}{\partial x}\right) + \frac{\partial}{\partial y} \left(\eta \frac{\partial u}{\partial y}\right) + \frac{\partial}{\partial z} \left(\eta \frac{\partial u}{\partial z}\right)$$

End of Notes to Section 1.1

1.2 Basic concepts of NHT, its importance and application examples

1.2.1 Three fundamental approaches of scientific research and their relationships

1.2.2 Basic concepts of numerical solutions based on continuum assumption

1.2.3 Classification of numerical solution methods based on continuum assumption

1.2.4 Importance and application examples

1.2.5 Stories of two celebrities (名人) in numerical simulation

1.2.6 Some suggestions

1.2 Basic concepts of NHT , importance and its application examples

1.2.1 Three fundamental approaches of scientific research and their relationships

1. Theoretical analysis (Analytical solution)

Its importance should not be underestimated (低估). It provides comparison for verifying(验证) numerical solutions.

Examples: The analytic solution of velocity from NS eq. for following case:

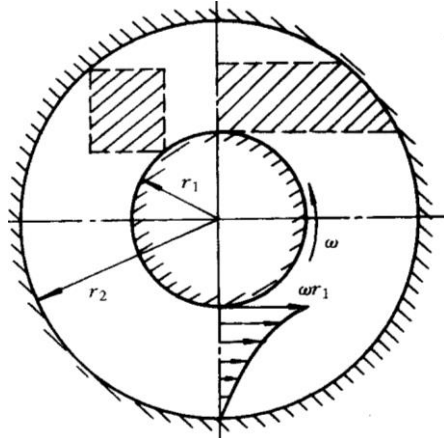

$$\frac{u}{u_1} = \frac{r_1 / r_2}{1 - (r_1 / r_2)^2} \bullet \frac{1 - (r / r_2)^2}{r / r_2}$$

$$u_1 = \omega r_1$$

2. Experimental study

A basic research method: observation(观察);
properties measurement; verification of numerical results

3. Numerical simulation

Numerical simulation is an inter-discipline (交叉学科), and plays an important and un-replaceable role in exploring (探索) unknowns, promoting (促进) the development of science & technology, and for the safety of national defense (国防安全) .

With the rapid development of computer hardware (硬件), the importance and function of the numerical simulation become greater and greater.

1.2.2 Basic concepts of numerical solutions based on continuum assumption (连续性假设)

Replacing the fields of continuum variables (velocity, temp. etc.) by sets (集合) of values at discrete (离散的) points (nodes, grids 节点) (Discretization of domain, 区域离散);

Establishing algebraic equations for these values at the discrete points by some principles (Discretization of equations, 方程离散);

Solving the algebraic equations by computers to get approximate solutions of the continuum variables (Solution of equation, 方程求解).

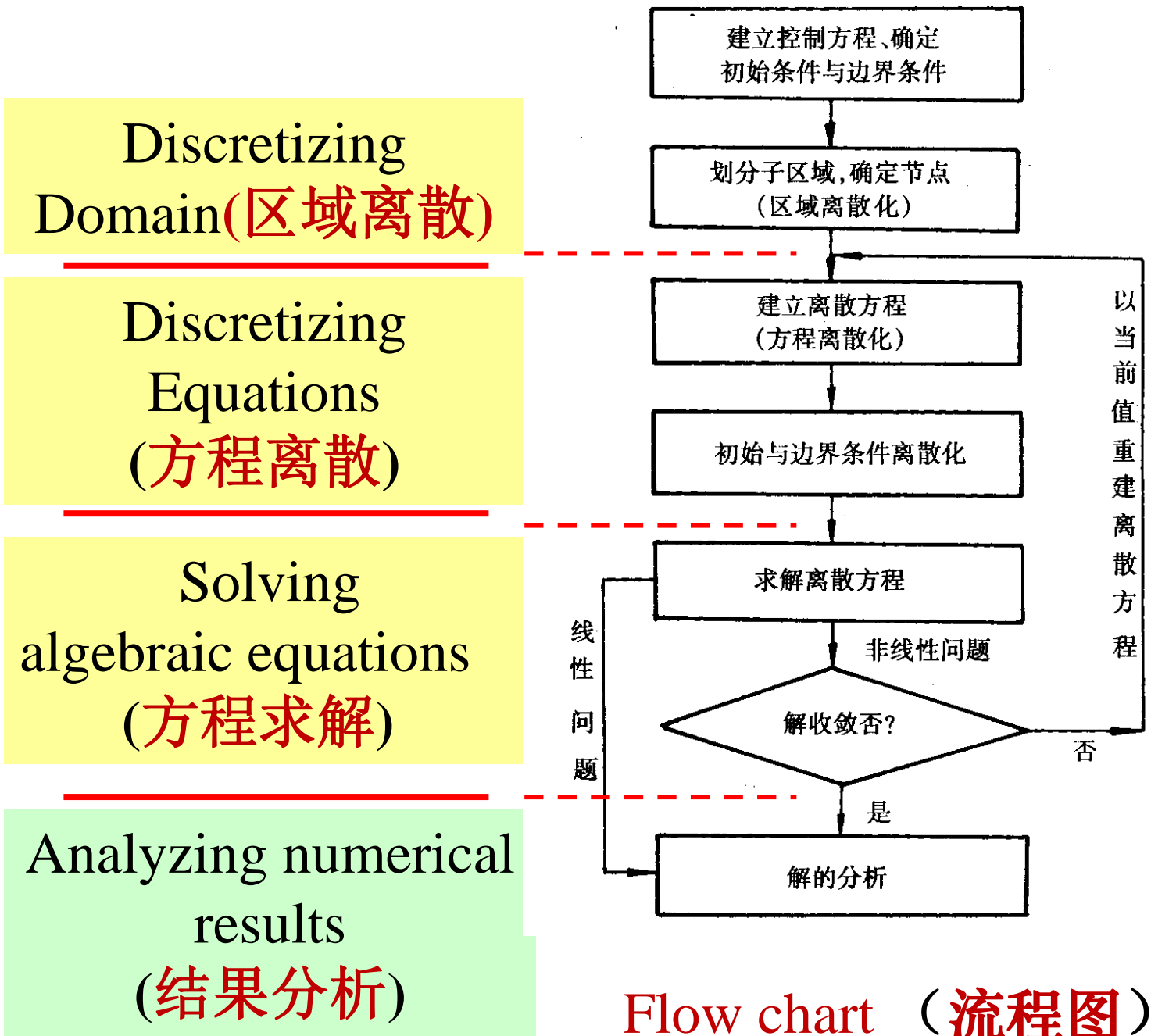

Flow chart (流程图)

1.2.3 Classification of numerical solution methods based on continuum assumption

1. Finite difference method (**FDM**)

有限差分法: L F Richardson (1910), A Thome (1940s)

2. Finite volume method (**FVM**)

有限容积法: D B Spalding; S V Patankar

3. Finite element method (**FEM**)

有限元法: O C Zienkiewicz; 冯康 (Kang Feng)

4. Finite analytic method (**FAM**)

有限分析法: 陈景仁(Ching Jen Chen)

5. Boundary element method (**BEM**)

边界元法: D B Brebbia

6. Spectral analysis method (**SAM**)

谱分析法

Comparisons of FDM(a),FVM(b),FEM(c),FAM(d)

FDM
有限差分

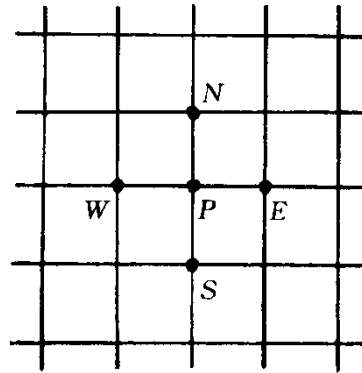

(a)

FVM
有限容积

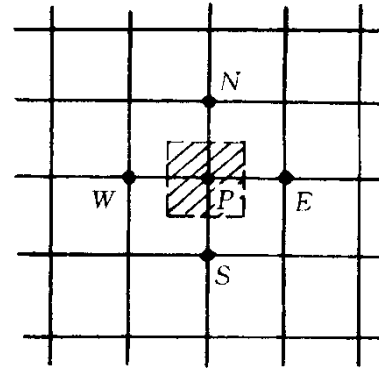

(b)

FEM
有限元

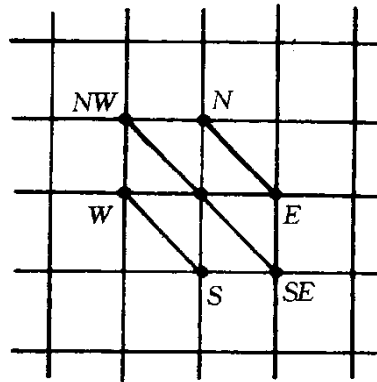

(c)

FAM
有限分析

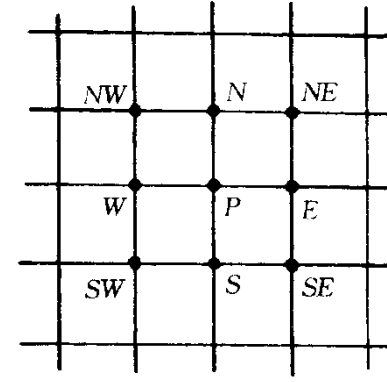

(d)

All these methods need a grid system (网格系统):
1) Determination of grid positions; 2) Establishing the influence relationships between grids.

BEM

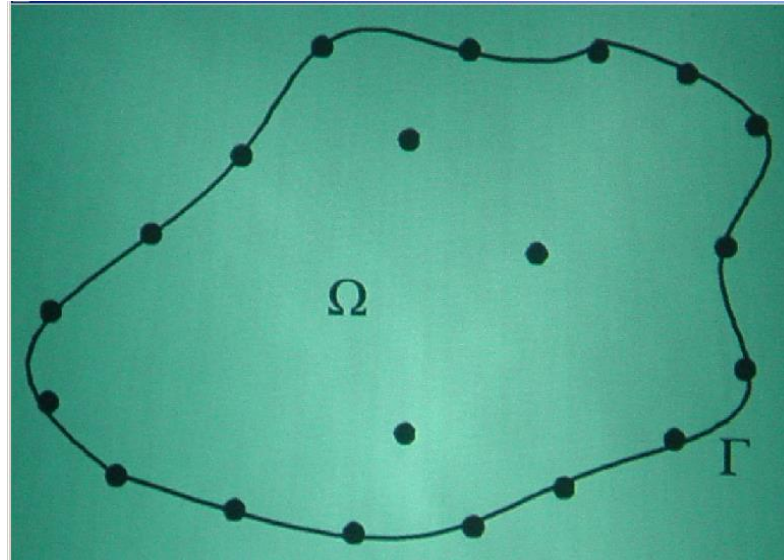

BEM (边界元) requires a basic solution(基准解), which greatly limits its applications in convective problems.

SAM can only be applied to geometrically simple cases.

Manole, Lage 1990—1992 statistics (统计): FVM ---47%; adopted by most commercial software; Our statistics of NHT in 2007 even much higher.

1.2.4 Importance and application examples

1. Application examples

Example 1 : Weather forecast—

Numerical solution is the only way.

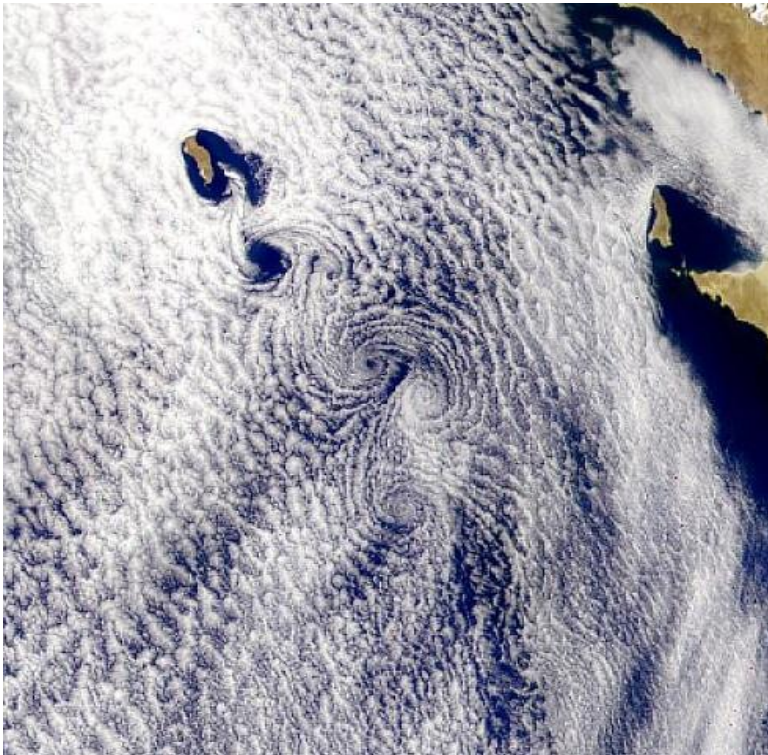

Large scale vortex



Cloud Atlas sent back by a meteorological satellite

Example 2: Aeronautical & aerospace (航空航天) engineering

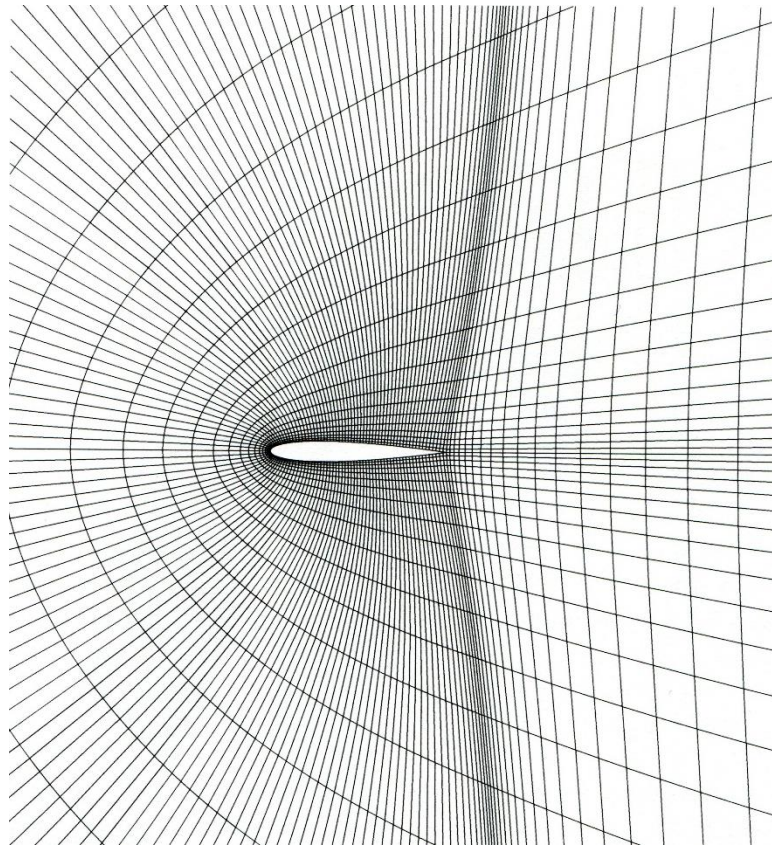

Partial view of grid system around
NACA 0012 airfoil (机翼)

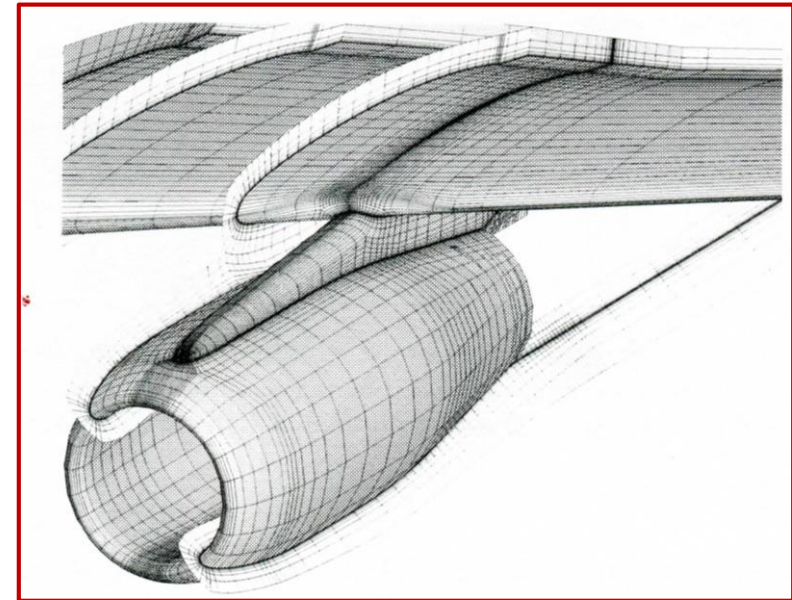
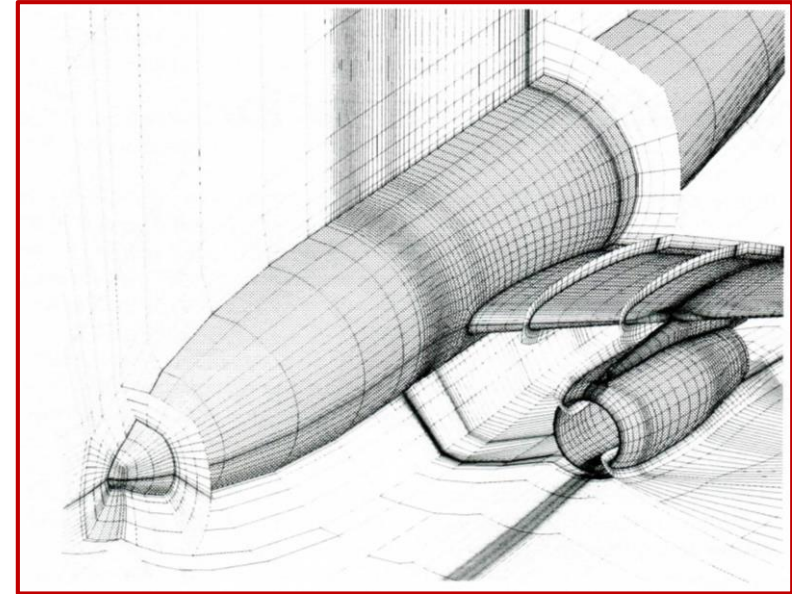

Example 4: Simulation of breaking dam (溃坝)

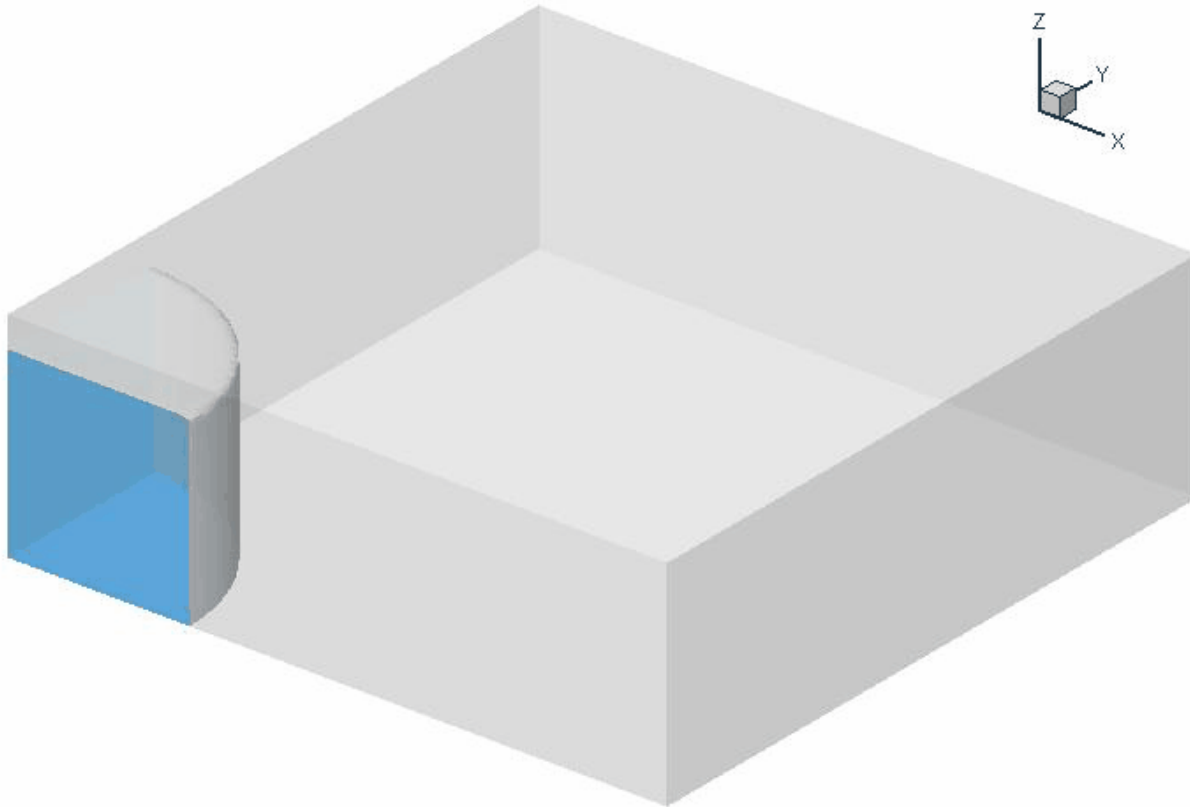

Evolution (演变) process of interface

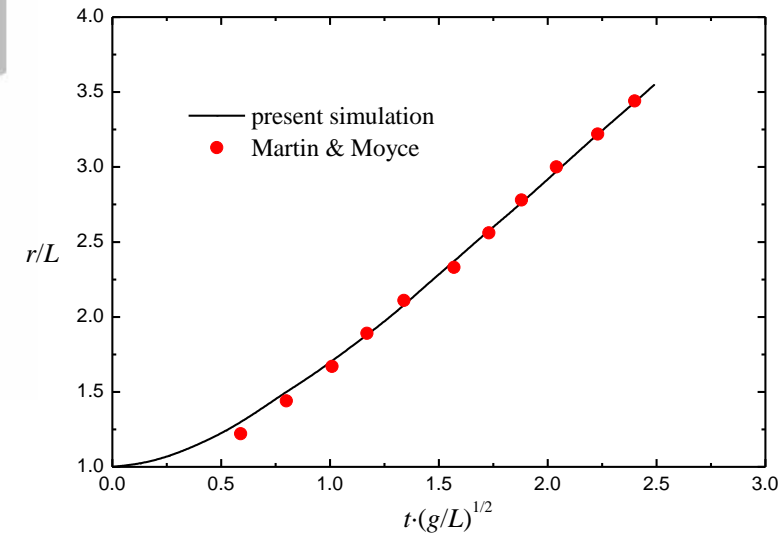

Base radius vs. time

2. Importance of numerical simulation

Historically, in 1985 the West Europe listed the first commercial software-**PHEONICS** as the one which was not allowed to sell to the communist countries. The prohibition (禁令) was cancelled in 1990s.

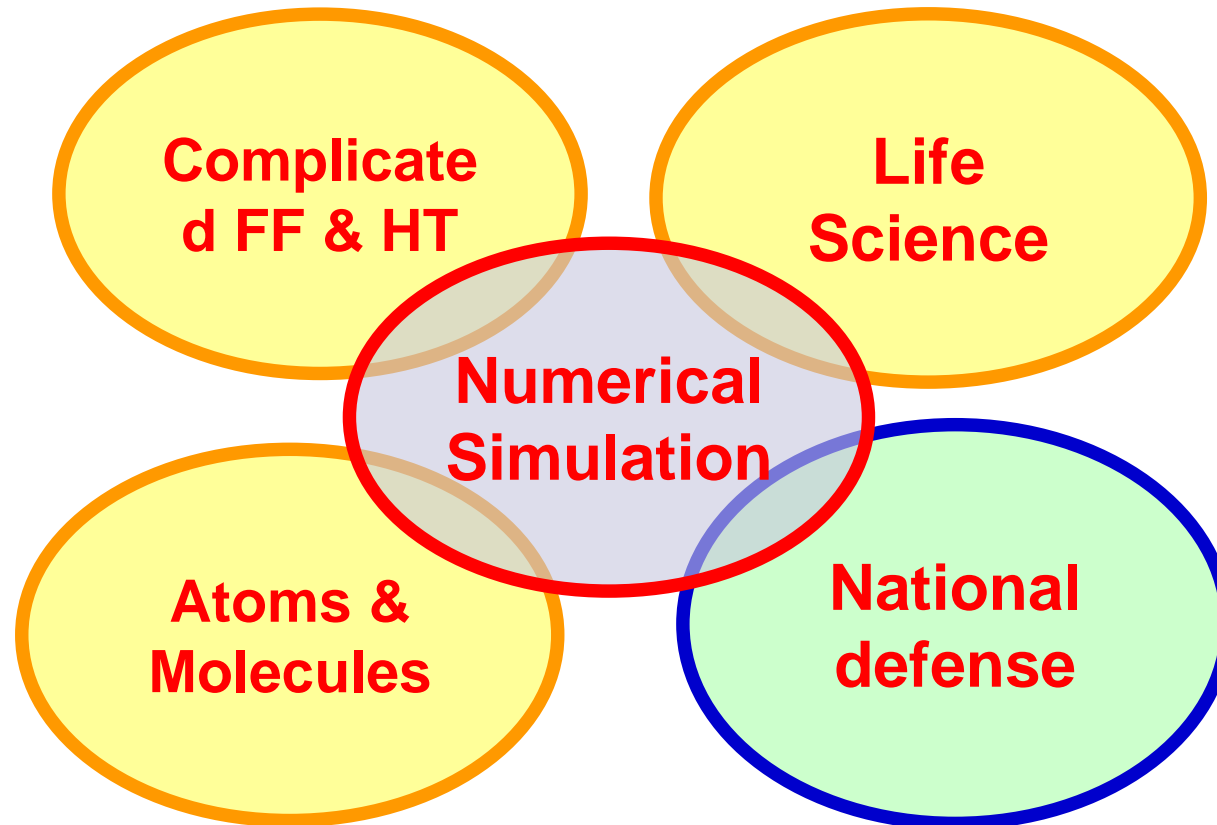

In 2005 the USA President Advisory Board put forward a suggestion to the president that in order to keep competitive power (竞争力) of USA in the world it should develop scientific computation.

In the year of 2006 the director of design department of Boeing, M. Grarett, reported to the US Congress (国会) indicating that the high performance computers have completely changed the way of designing Boeing airplane.

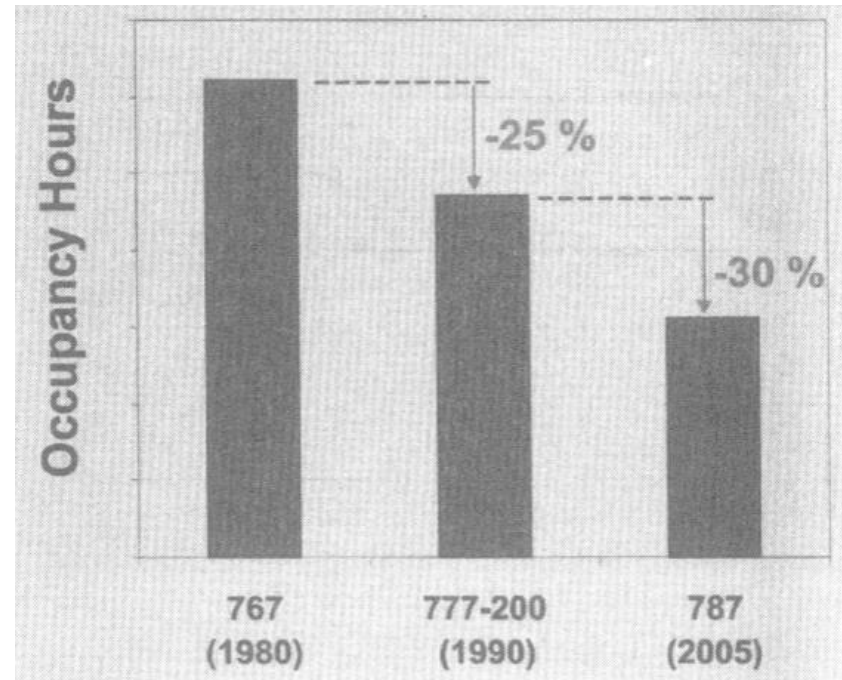

Numerical simulation plays an important role in the design of Boeing airplane

Recently, the Trump administration in USA has banned (禁止) Harbin Institute of Technology and Harbin University of Engineering from using MATLAB. MATLAB is an important tool for engineering design and research.

Therefore independently developed software or home-made software is very important for a country's development.

Graduate students at a research-led university should have the capability to independently develop a software.

To meet such requirement this course is composed of following three major parts:

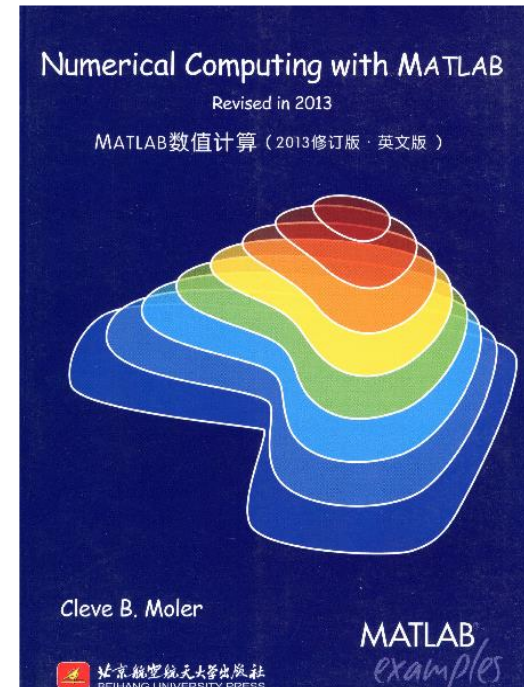

- Part 1: Fundamental theories of numerical heat transfer,**
You will learn basic numerical solution methods for incompressible fluid flow and heat transfer. **(36 hours)**
- Part 2: 2D-teaching code by FORTRAN-95,** which contains only about 700 sentences while is able to simulate fluid flow and heat transfer problems in three 2D coordinates; **This part cultivates (培养) students' ability to write programs for themselves. (8 hours)**
- Part 3: Commercial software FLUENT,** including fundamentals and applications (12 hours). **This part cultivates students' ability to apply commercial software to solve complicated engineering problems .**

1.2.5 Stories of two celebrities (名人) in numerical simulation

1. Kang FENG (冯康)



叶笃正，气象学家
中科院院士

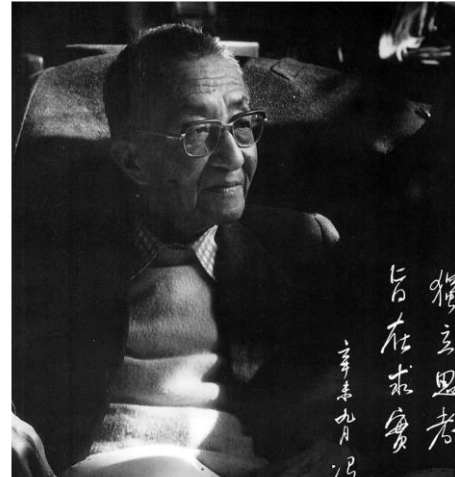

冯康，数学家
中科院院士

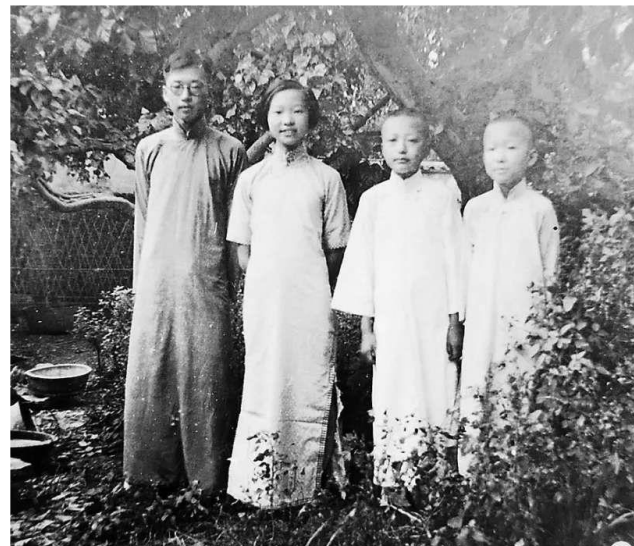

冯端，物理学家
中科院院士



Professor K.FENG developed very strict and beautiful mathematical theory of finite element method. He was not married for his whole life, and devoted himself to the innovation of science & technology in China .



Commemoration of 100th birthday of Feng KANG(2020)



2. D.B. Spalding (UK)

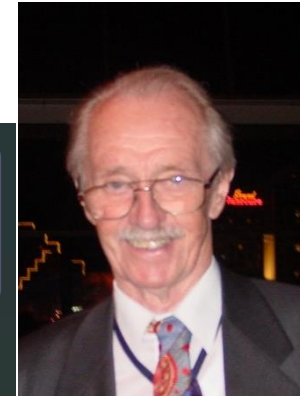

were to be released in a city?

**Next time we will meet on
September 26 afternoon
(1,2 classes) for the classes of
October 6 (Wednesday)**

1.3 Mathematical and physical classification (分类) of HT & FF problems and its effects on numerical solution

1.3.1 From mathematical viewpoint (观点)

1. General form of 2nd-order PDE (偏微分方程) with two independent variables (二元)
2. Basic features (特点) of three types of PDEs
3. Relationship to numerical solution method

1.3.2 From physical viewpoint

Conservative (守恒型) and non-conservative

1.3 Mathematical and physical classification of FF & HT Problems and its effects on numerical solutions

1.3.1 From mathematical viewpoint

1. General formulation of 2nd order PDEs with two IDVs

$$a\phi_{xx} + b\phi_{xy} + c\phi_{yy} + d\phi_x + e\phi_y + f\phi = g(x, y)$$

a, b, c, d, e, f can be function of x, y, ϕ

$$b^2 - 4ac \begin{cases} < 0, \text{ Elliptic} & \boxed{\text{椭圆型}} \quad (\text{回流型}) \\ = 0, \text{ Parabolic} & \boxed{\text{抛物型}} \quad (\text{边界层}) \\ > 0, \text{ Hyperbolic} & \boxed{\text{双曲型}} \end{cases}$$

2. Basic feature of three types of PDEs

$b^2 - 4ac < 0$, having no real characteristic line;
(没有实的特征线)

$b^2 - 4ac = 0$, having one real characteristic line;

$b^2 - 4ac > 0$, having two real characteristic lines

leading to the difference in domain of dependence
(DOD, 依赖区) and domain of influence (DOI, 影响区);

For 2-D case, DOD of a node is a line which determines the value of a dependent variable at the node; DOI of a node is an area within which the values of dependent variable are affected by the node.

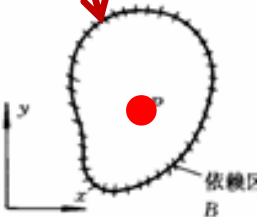
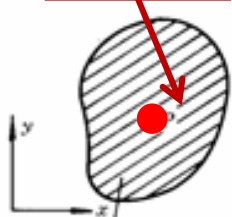
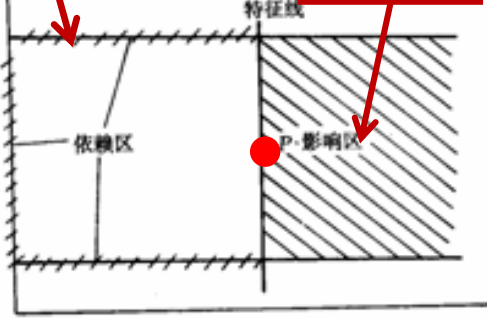
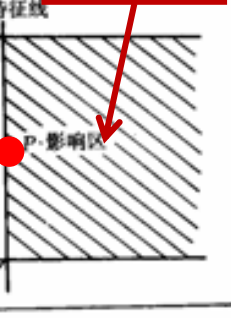
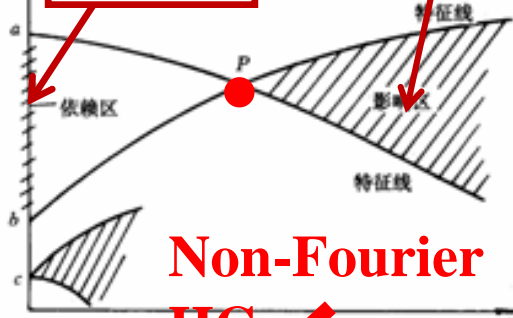
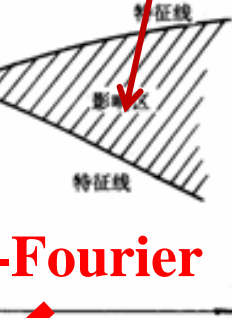
Elliptic	Parabolic	Hyperbolic
<div style="display: flex; justify-content: space-around;"> <div style="text-align: center;"> <div style="border: 1px solid red; padding: 2px; font-weight: bold; color: black;">DOD</div>  <p>依赖区 B</p> </div> <div style="text-align: center;"> <div style="border: 1px solid red; padding: 2px; font-weight: bold; color: black;">DOI</div>  <p>影响区 R</p> </div> </div>	<div style="display: flex; justify-content: space-around;"> <div style="text-align: center;"> <div style="border: 1px solid red; padding: 2px; font-weight: bold; color: black;">DOD</div>  <p>特征线 依赖区</p> </div> <div style="text-align: center;"> <div style="border: 1px solid red; padding: 2px; font-weight: bold; color: black;">DOI</div>  <p>P-影响区</p> </div> </div>	<div style="display: flex; justify-content: space-around;"> <div style="text-align: center;"> <div style="border: 1px solid red; padding: 2px; font-weight: bold; color: black;">DOD</div>  <p>特征线 依赖区</p> </div> <div style="text-align: center;"> <div style="border: 1px solid red; padding: 2px; font-weight: bold; color: black;">DOI</div>  <p>特征线 影响区</p> </div> </div> <p style="color: red; font-weight: bold; text-align: center;">Non-Fourier HC</p>
<div style="background-color: #ffffcc; padding: 10px;"> $\frac{\partial^2 T}{\partial x^2} + \frac{\partial^2 T}{\partial y^2} = 0$ <p style="text-align: right; color: red; font-weight: bold;">Steady HC</p> <p>$(a=1, b=0, c=1)$</p> $u \frac{\partial u}{\partial x} + v \frac{\partial u}{\partial y} = -\frac{1}{\rho} \frac{\partial p}{\partial x}$ $+ \nu \left(\frac{\partial^2 u}{\partial x^2} + \frac{\partial^2 u}{\partial y^2} \right)$ </div>	<div style="background-color: #e0ffff; padding: 10px;"> $\frac{\partial T}{\partial t} = a \frac{\partial^2 T}{\partial y^2}$ <p style="text-align: right; color: red; font-weight: bold;">Un- Steady HC</p> <p>$(a=0, b=0, c=a)$</p> $u \frac{\partial u}{\partial x} + v \frac{\partial u}{\partial y} = -\frac{1}{\rho} \frac{\partial p}{\partial x}$ $+ \nu \frac{\partial^2 u}{\partial y^2}$ </div>	<div style="background-color: #ffe0cc; padding: 10px;"> $\frac{1}{a} \frac{\partial T}{\partial t} + \frac{1}{c^2} \frac{\partial^2 T}{\partial t^2} = \frac{\partial^2 T}{\partial y^2}$ <p>$(a=1/c^2, b=0, c=-1)$</p> $\frac{\partial^2 \phi}{\partial t^2} = C^2 \frac{\partial^2 \phi}{\partial y^2}$ <p>$(a=1, b=0, c=-C^2)$</p> </div>

$$a\phi_{xx} + b\phi_{xy} + c\phi_{yy} \dots$$

3. Relationship with numerical methods

(1) **Elliptic**: flow **with recirculation** (回流), solution should be conducted simultaneously for the whole domain;

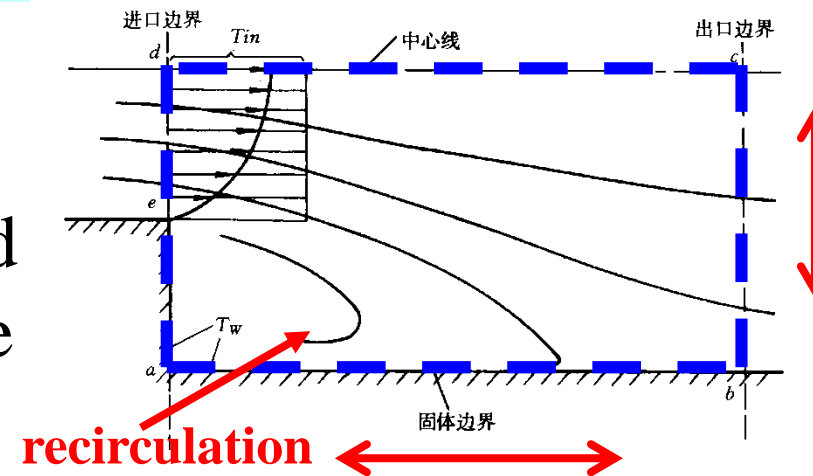

(2) **Parabolic**: flow **without recirculation**, solution can be conducted by marching method (步进方法), greatly saving computing time!

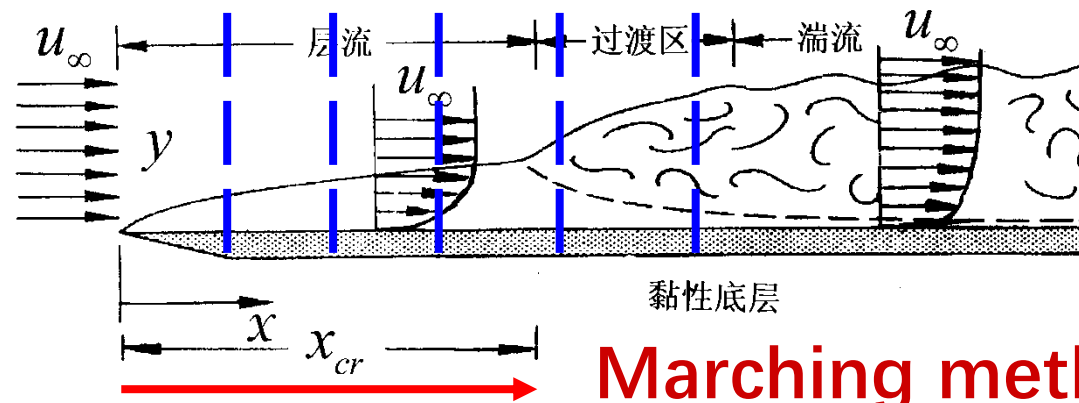

1.3.2 From physical viewpoint

1. Conservative (守恒型) vs. non-conservative:

Non-conservative: those governing equations whose convective terms are not expressed by divergence form are called **non-conservative governing equation**. For 2D

energy eq.: $u \frac{\partial(\rho c_p T)}{\partial x} + v \frac{\partial(\rho c_p T)}{\partial y}$ is not divergence form

Conservative: those governing equations whose convective terms are expressed by divergence form(散度形式) are called **conservative governing equation**.

$$\frac{\partial(\rho u c_p T)}{\partial x} + \frac{\partial(\rho v c_p T)}{\partial y} \rightarrow \frac{\partial(\rho c_p T u)}{\partial x} + \frac{\partial(\rho c_p T v)}{\partial y} = \text{div}(\rho c_p T \vec{U})$$

These two concepts are only for numerical solution.

2. Conservative GE. can guarantee the conservation of physical quantity (mass, momentum ,energy , etc.) within a **finite (有限大小) volume.**

$$\frac{\partial(\rho c_p T)}{\partial t} + \text{div}(\rho c_p T \vec{U}) = \text{div}(\lambda \text{grad} T) + S_T c_p$$

$$\frac{\partial}{\partial t} \int_V (\rho c_p T) dV = - \int_V \text{div}(\rho c_p T \vec{U}) dV + \int_V \text{div}(\lambda \text{grad} T) dV + \int_V S_T c_p dV$$

From Gauss theorem

$$\int_V \text{div}(\rho c_p T \vec{U}) dV = \int_{\partial V} (\rho c_p T \vec{U}) \bullet \vec{n} dA$$

$$\int_V \text{div}(\lambda \text{grad} T) dV = \int_{\partial V} (\lambda \text{grad}(T)) \bullet \vec{n} dA$$

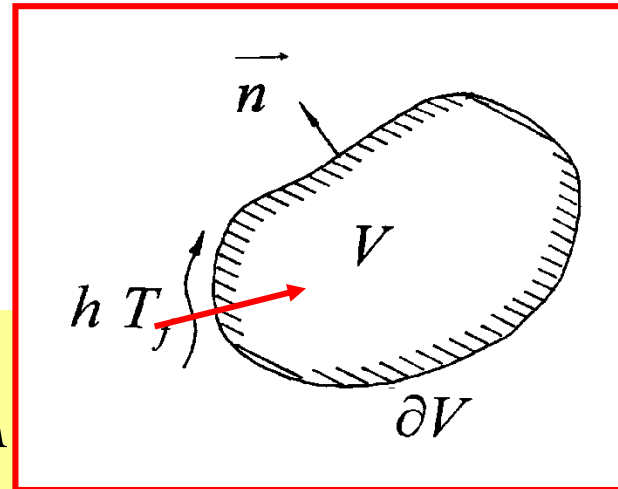

Dot product (点积)

$$\frac{\partial}{\partial t} \int_V (\rho c_p T) dV = - \int_{\partial V} (\rho c_p T \vec{U}) \cdot \vec{n} dA + \int_{\partial V} (\lambda \text{grad}(T)) \cdot \vec{n} dA + \int_V (S_T c_p) dV$$

**Increment
(增量) of
internal energy**

**Energy into
the region by
fluid flow**

**Energy into
the region by
conduction**

**Energy
generated
by source**

Exactly an expression of energy conservation!

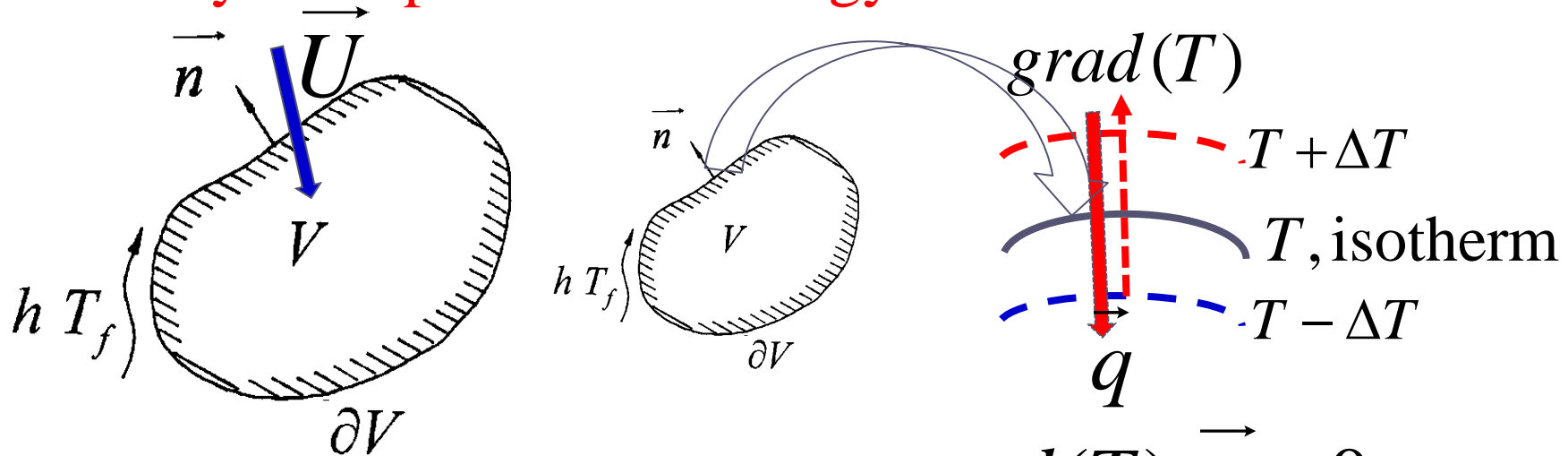

$\vec{U} \cdot \vec{n} < 0;$
 $-\vec{U} \cdot \vec{n} > 0$, heat flows in

$\text{grad}(T) \cdot \vec{n} > 0$
heat conducts in

Key to have a conservative form of governing equation:
convective term is expressed by divergence.

3. Generally conservation is expected. Discretization eqs. are suggested to be derived from conservative PDE.

4. Conservative and non-conservative are referred to (指) a finite space (有限空间); For a differential volume (微分容积) they are identical (恒等的) !

$$\begin{aligned}
 u \frac{\partial(\rho c_p T)}{\partial x} + v \frac{\partial(\rho c_p T)}{\partial y} + \rho u c_p \left(\frac{\partial u}{\partial x} + \frac{\partial v}{\partial y} \right) &= 0 \\
 &= \frac{\partial(\rho u c_p T)}{\partial x} + \frac{\partial(\rho v c_p T)}{\partial y}
 \end{aligned}$$

Summary of Section 1-3

1. The governing eqs. of HT and FF are of 2nd order PDE:

$$a\phi_{xx} + b\phi_{xy} + c\phi_{yy} + d\phi_x + e\phi_y + f\phi = g(x, y)$$

and depending on the value of $(b^2 - 4ac)$, it can be **elliptic, parabolic** or **hyperbolic**;

The HT and FF problems of the incompressible fluid are either elliptic or parabolic;

2. If the convective term of a governing eq. is expressed by the divergence form it is conservative, otherwise it is non-conservative; Discretization eqs. are suggested to be derived from conservative PDE.

Summary of Chapter 1

It is now widely accepted that an appropriate combination of theoretical analysis, experimental study and numerical simulation is the best approach for modern scientific research.

With the further development of computer hardware and numerical algorithm (算法), the importance of numerical simulation will become more and more significant!

A new era of applying numerical simulation has already come with the emergence of the profound changes unseen in a century (随着百年未有之大变局的出现, 数值模拟应用的新时代已经到来)!

Some Suggestions for learning the course

1. Understanding numerical methods from basic characteristics of physical process;
2. Mastering complete picture and knowing every details (明其全，析其微) for any numerical method;
3. Practicing simulation method by a computer; Work hard to develop your ability to write code for yourself;
4. Trying hard to analyze simulation results: rationality (合理性) and regularity (规律性);
5. Adopting CSW(商业软件) in conjunction with self-developed code (与自编程序相结合).

Home Work 1

Lid-driven cavity flow with heat transfer (带传热的顶盖驱动流)

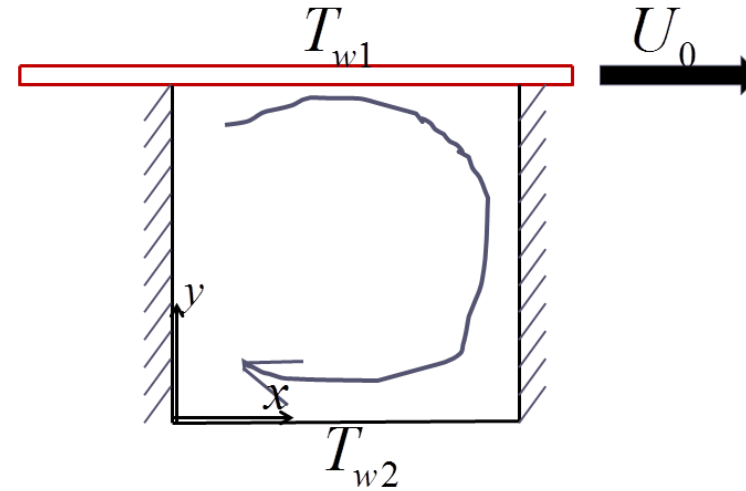

An infinite long plate with uniform temperature T_{w1} is moving at the top of a square cavity. The left and right walls are adiabatic(绝热), while the bottom wall is at temperature T_{w2} . The effect of gravity can be neglected. Write down the mathematical formulation for the FF & HT in the cavity assuming steady state, laminar flow with constant properties and without energy dissipation.

Hand in with the home work of Chapter 2.

The pdf file will be posted at our group website:

<http://nht.xjtu.edu.cn>

Lecture today ---Chapter 1 of NHT textbook

Erratum (勘误表)

1. 第3页中间: $-2/3$ 应改为 $-2/3 \eta$
2. 第3页倒数第3行: $-\frac{\partial p}{\partial x}$ 应改为 $-\frac{\partial p}{\partial x} + \rho F_x$
倒数第1, 2行仿此修改。
3. 第4页倒数第3行: $\lambda \text{div} \mathbf{U}$ 应改为 $\lambda (\text{div} \mathbf{U})^2$
4. 第7页 式(1-18)中右端: ρ 应改为 p
5. 第9页倒数第3、4行右端: 扩散项前的系数应为 ν
6. 式(1-6),(1-8)中漏了重力项。

本组网页地址: <http://nht.xjtu.edu.cn> 欢迎访问!
Teaching PPT will be loaded on our website



同舟共济
渡彼岸!

People in the
same boat help
each other to
cross to the other
bank, where....