

Numerical Heat Transfer

(数值传热学)

Chapter 3 Numerical Methods for Solving Diffusion Equation and their Applications (2)



Instructor Tao, Wen-Quan

Key Laboratory of Thermo-Fluid Science & Engineering
Int. Joint Research Laboratory of Thermal Science & Engineering
Xi'an Jiaotong University
Xi'an, 2019-Sept-24

Contents

3.1 1-D Heat Conduction Equation

3.2 Fully Implicit Scheme of Multi-dimensional Heat Conduction Equation

3.3 Treatments of Source Term and B.C.

3.4 TDMA & ADI Methods for Solving ABEs

3.5 Fully Developed HT in Circular Tubes

3.6 Fully Developed HT in Rectangle Ducts

3.4 TDMA & ADI Methods for Solving ABEs

3.4.1 TDMA algorithm (算法) for 1-D conduction problem

1. General form of algebraic equations of 1-D conduction problems
2. Thomas algorithm
3. Treatment of 1st kind boundary condition

3.4.2 ADI method for solving multi-dimensional problem

1. Introduction to the matrix of 2-D problem
2. ADI iteration of Peaceman-Rachford

3.4 TDMA & ADI Methods for Solving ABEqs

3.4.1 TDMA algorithm for 1-D conduction problem

1. General form of algebraic equations. of 1-D conduction problems

The ABEqs for steady and unsteady ($f > 0$) problems take the following form

$$a_P T_P = a_E T_E + a_W T_W + b$$

The matrix (矩阵) of the coefficients is a **tri-diagonal** (三对角) one .

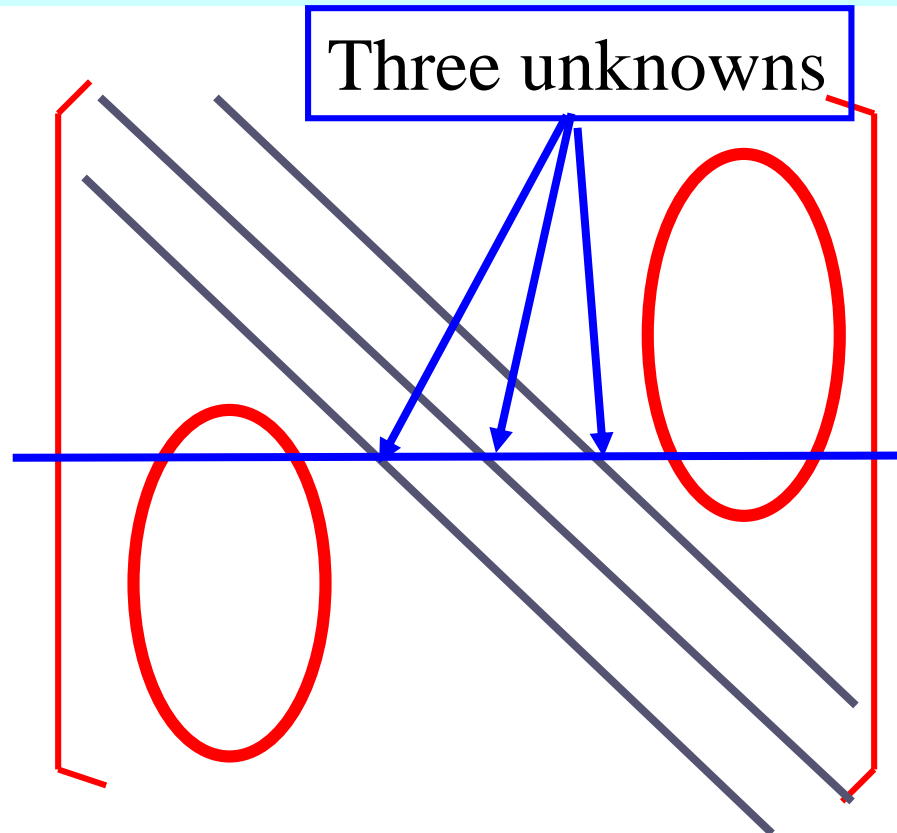

2. Thomas algorithm(算法)

The numbering method of W-P-E is humanized (人性化), but it can not be accepted by a computer!

Rewrite above equation:

$$A_i T_i = B_i T_{i+1} + C_i T_{i-1} + D_i, \quad i = 1, 2, \dots, M-1 \quad (\text{a})$$

End conditions: $i=1, C_i=0; i=M-1, B_i=0$

(1) Elimination (消元) – Reducing the unknowns at each line from 3 to 2

Assuming the eq. after elimination as

$$T_{i-1} = P_{i-1} T_i + Q_{i-1} \quad (\text{b})$$

Coefficient has been treated to 1.

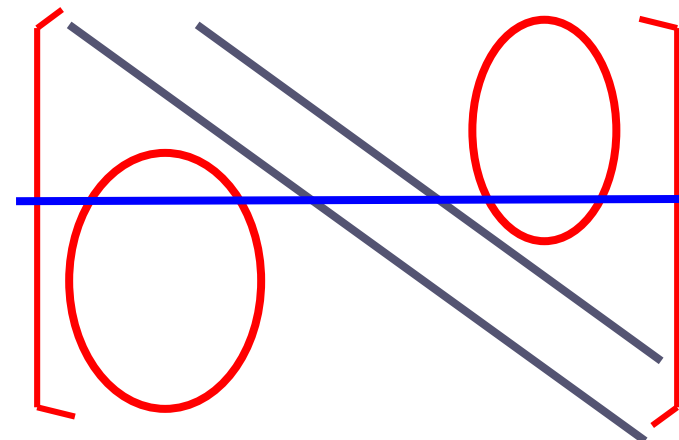

The purpose of the elimination procedure is to find the relationship between P_i , Q_i with A_i , B_i , C_i , D_i :

Multiplying Eq.(b) by C_i , and adding to Eq.(a):

$$A_i T_i = B_i T_{i+1} + \cancel{C_i T_{i-1}} + D_i \quad (\text{a})$$

$$\cancel{C_i T_{i-1}} = C_i P_{i-1} T_i + C_i Q_{i-1} \quad (\text{b})$$

$$A_i T_i - C_i P_{i-1} T_i = B_i T_{i+1} + D_i + C_i Q_{i-1}$$

Yielding

$$T_i = \left(\frac{B_i}{\underbrace{A_i - C_i P_{i-1}}_{\downarrow}} \right) T_{i+1} + \frac{D_i + C_i Q_{i-1}}{\underbrace{A_i - C_i P_{i-1}}_{\downarrow}}$$

Comparing with $T_{i-1} = P_{i-1} T_i + Q_{i-1}$

$$P_i = \frac{B_i}{A_i - C_i P_{i-1}}; \quad Q_i = \frac{D_i + C_i Q_{i-1}}{A_i - C_i P_{i-1}};$$

The above equations are **recursive (递归的)**—i.e.,

In order to get P_i , Q_i , P_1 and Q_1 must be known.

In order to get P_1 , Q_1 , use Eq.(a)

$$A_i T_i = B_i T_{i+1} + C_i T_{i-1} + D_i, \quad i = 1, 2, \dots, M-1 \quad \mathbf{(a)}$$

End condition: $i=1, C_i=0; i=M-1, B_i=0$

Applying Eq.(a) to $i=1$, and comparing it with

Eq.(b), the expressions of P_1 , Q_1 can be obtained:

From $i = 1, C_1 = 0, A_1 T_1 = B_1 T_2 + D_1$

$$T_1 = \frac{B_1}{A_1} T_2 + \frac{D_1}{A_1} \quad \longrightarrow \quad P_1 = \frac{B_1}{A_1}; \quad Q_1 = \frac{D_1}{A_1}$$

(2) Back substitution(回代) – Starting from M1 via Eq.(b) to get T_i sequentially (顺序地)

$$T_{M1} = P_{M1} T_{M1+1} + Q_{M1}, \quad P_i = \frac{B_i}{A_i - C_i P_{i-1}};$$

End condition:
 $i = M1, B_i = 0$

$$\longrightarrow P_{M1} = 0$$

$$T_{M1} = Q_{M1} \quad \boxed{T_{i-1} = P_{i-1} T_i + Q_{i-1}} \quad \text{to get: } T_{M1-1}, \dots, T_2, T_1.$$

3. Implementation of Thomas algorithm for 1st kind B.C.

For 1st kind B.C., the solution region is from $i=2, \dots$ to $M_1-1=M_2$.

Applying Eq.(b) to $i=1$ with given $T_{1,\text{given}}$:

$$T_1 = P_1 T_2 + Q_1 \longrightarrow P_1 = 0; Q_1 = T_{1,\text{given}}$$

Because T_{M_1} is known, back substitution should be started from M_2 :

$$T_{M_2} = P_{M_2} T_{M_1} + Q_2$$

When the ASTM is adopted to deal with B.C. of 2nd and 3rd kind, **the numerical B.C. for all cases is regarded as 1st kind**, and the above treatment should be adopted.

3.4.2 ADI method for solving multi-dimensional problem

1. Introduction to the matrix of 2-D problem

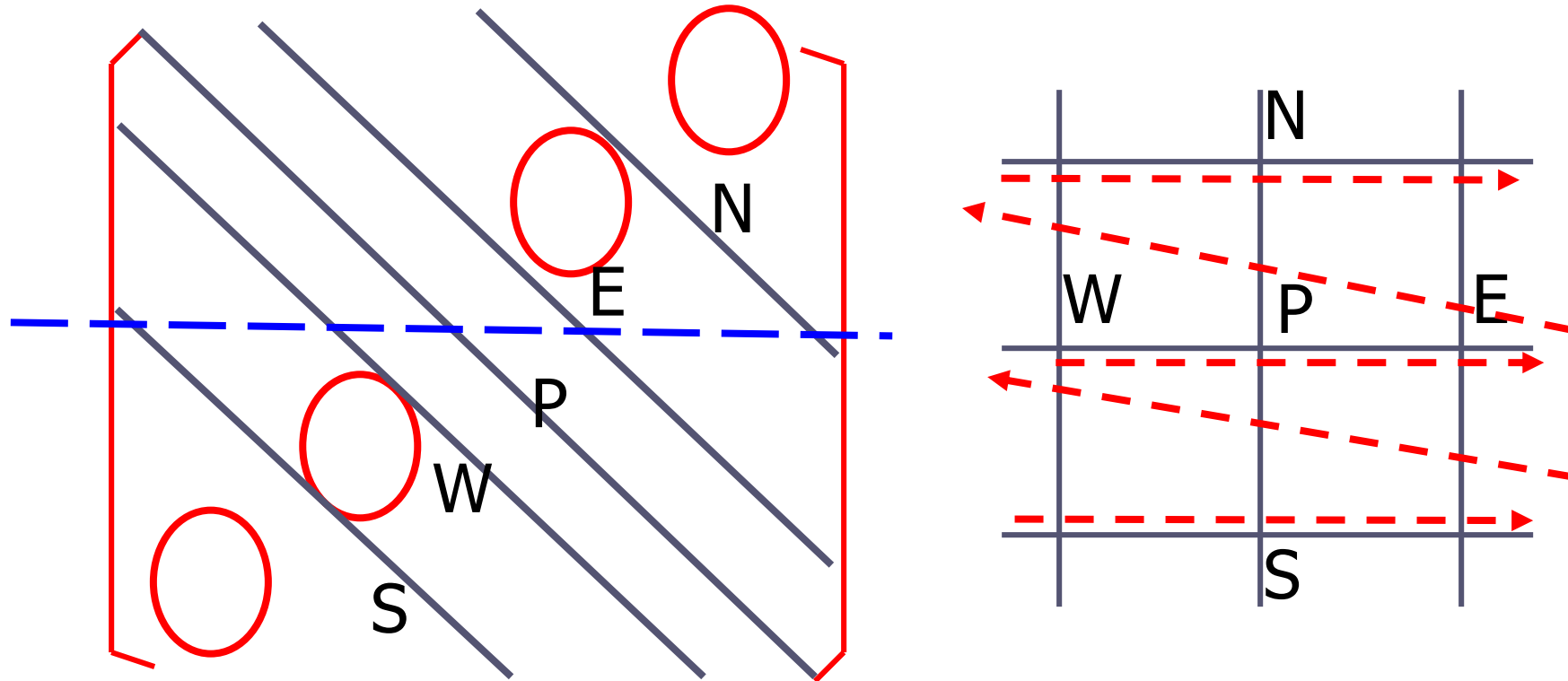

1-D storage (一维存储) of variables and its relation to matrix coefficients

Numerical methods for solving ABEqs. of 2-D problems.

- (1) Penta-diagonal algorithm(PDMA, 五对角阵算法)
- (2) Alternative (交替的)-direction implicit (ADI, 交替方向隐式方法)

2. 3-D Peaceman-Rachford ADI method

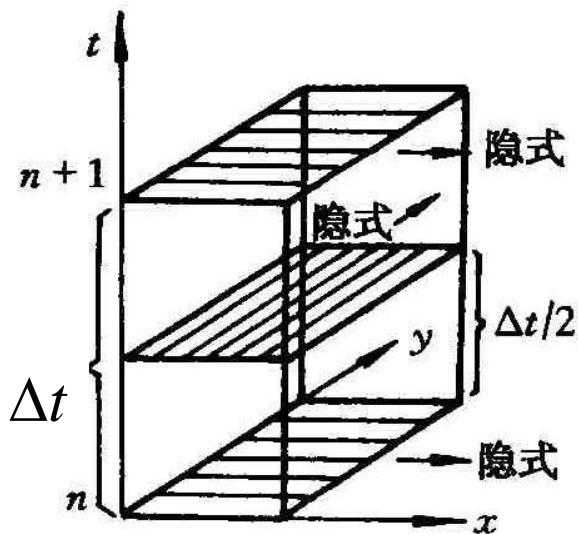

2-D ADI

Dividing Δt into three uniform parts
 In the 1st $\Delta t / 3$ implicit in x direction,
 and explicit in y, z directions;
 In the 2nd and 3rd $\Delta t / 3$ implicit in
 y, z direction, respectively.

Set $u_{i,j,k}$, $v_{i,j,k}$ the temporary(临时的) solutions at two sub-time levels

$\delta_x^2 T_{i,j,k}^n$ ---CD for 2nd derivative at n time level in x direction

1st sub-time level:
$$\frac{u_{i,j,k} - T_{i,j,k}^n}{\Delta t / 3} = a(\delta_x^2 u_{i,j,k} + \delta_y^2 T_{i,j,k}^n + \delta_z^2 T_{i,j,k}^n)$$

2nd sub-time level:
$$\frac{v_{i,j,k} - u_{i,j,k}^n}{\Delta t / 3} = a(\delta_x^2 u_{i,j,k} + \delta_y^2 v_{i,j,k} + \delta_z^2 u_{i,j,k}^n)$$

3rd sub-time level:
$$\frac{T_{i,j,k}^{n+1} - v_{i,j,k}^n}{\Delta t / 3} = a(\delta_x^2 v_{i,j,k} + \delta_y^2 v_{i,j,k}^n + \delta_z^2 T_{i,j,k}^{n+1})$$

It's obvious that this solution procedure is not fully implicit, and the time step is limited by following stability condition:

$$a\Delta t\left(\frac{1}{\Delta x^2} + \frac{1}{\Delta y^2} + \frac{1}{\Delta z^2}\right) \leq 1.5$$

If the time step is larger than the value specified by the above eq., the resulted numerical solutions will be oscillating . **We call the solution procedure is not stable.**

More discussion on the numerical stability will be presented in Chapter 7.

3.5 FDHT in Circular Tubes

3.5.1 Introduction to FDHT in tubes and ducts

3.5.2 Physical and Mathematical Models

3.5.3 Governing equations and their non-dimensional forms

3.5.4 Conditions for unique solution

3.5.5 Numerical solution method

3.5.6 Treatment of numerical results

3.5.7 Discussion on numerical results

3.5 Fully Developed HT in Circular Tubes

3.5.1 Introduction to FDHT in tubes and ducts

1. Simple fully developed heat transfer

Physically: Velocity components normal to flow direction equal zero; Fluid **dimensionless** temperature distribution is independent on (无关) the position in the flow direction

Mathematically: Both dimensionless momentum and energy equations are of **diffusion type**.

Present chapter is limited to the simple cases.

FDHT in straight duct is an example of simple cases.

$$\frac{\partial}{\partial x} \left(\frac{T_{w,m} - T}{T_{w,m} - T_b} \right) = 0$$

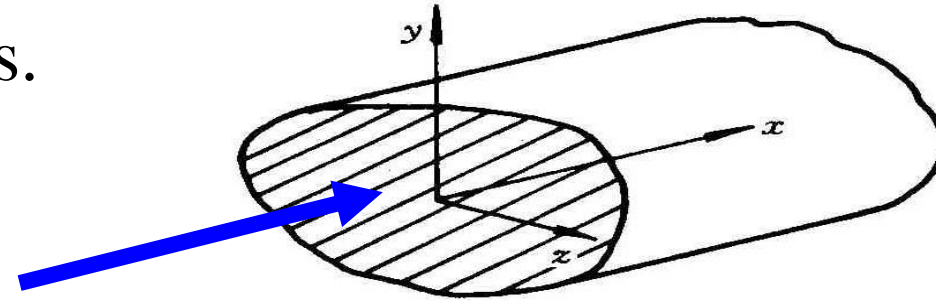

2. Complicated FDHT

In the cross section normal to flow direction there exist velocity components, and the dimensionless temperature depends on the axial position, often exhibits periodic (周期的) character. The full Navier-Stokes equations must be solved.

This subject is discussed in Chapter 11 of the textbook.

Examples of complicated FDHT

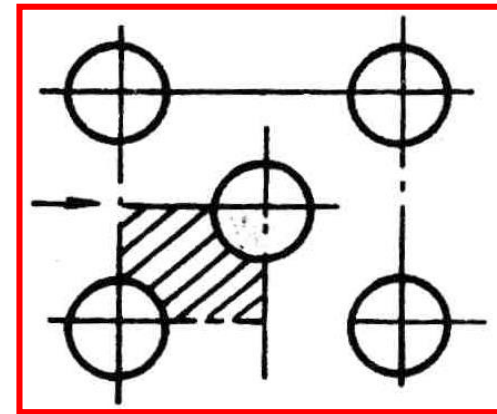
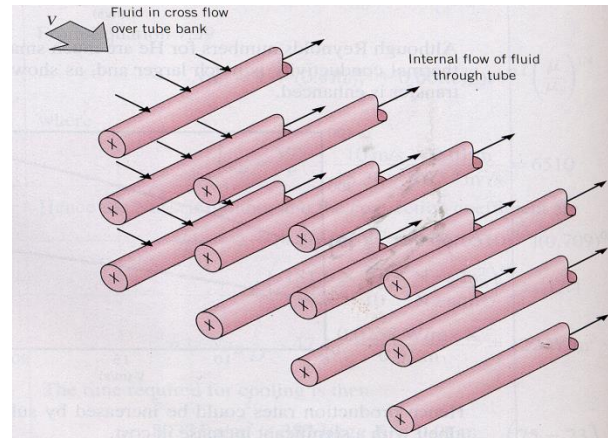

Tube bundle (bank) (管束)

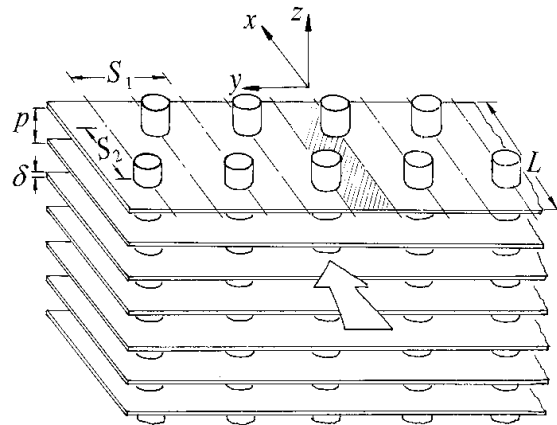

Fin-and-tube
heat exchanger

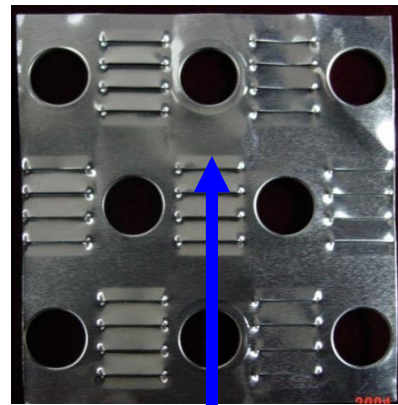

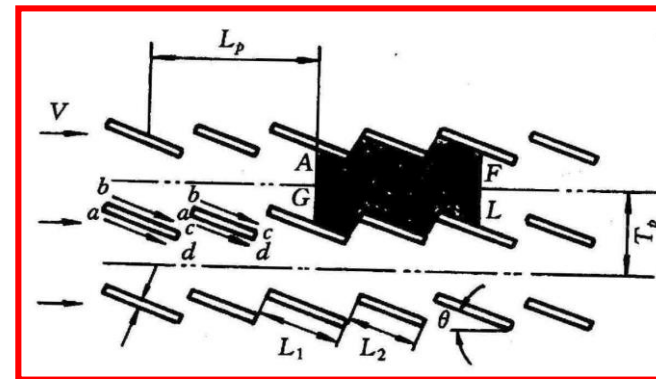

Louver fin (百叶窗翅片)

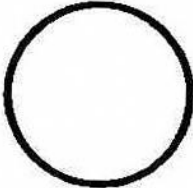

3. Collection of partial examples

Table 4-5 Numerical examples of simple FDHT

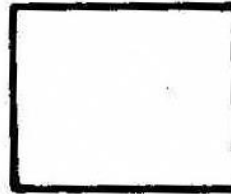
No	Cross section	B. Condition	Refs.
1		均匀壁温; 给定周向热流分布; 轴向热流呈指数变化; 外部对流换热	[23,24,25,26,27]
2		均匀壁温; 均匀热流及其组合	转引自[23]
3		均匀壁温; 周向任意分布热流; 轴向均匀热流; 一组对边均匀壁温, 另一线绝热	[28,29,30]

See pp. 106-109 of the textbbok for details

3.5.2 Physical and mathematical models of FDHT in circular tube

A laminar flow in a long tube is cooled (heated) by an external fluid with temperature T_∞ and heat transfer coefficient h_e . Determine the in-tube heat transfer coefficient and Nusselt number in the FDHT region.

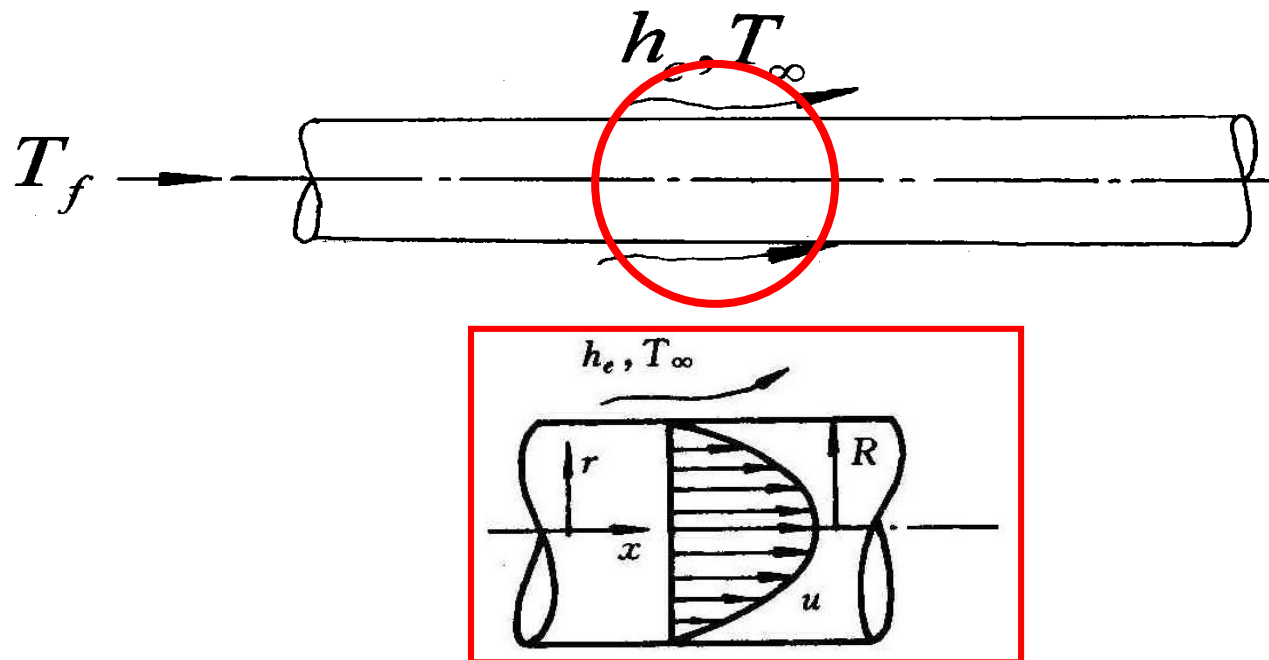

1. Simplification (简化) assumptions

- (1) Thermo-physical properties are constant ;
- (2) Axial heat conduction in the fluid is neglected;
- (3) Viscous dissipation (耗散) is neglected;
- (4) Natural convection is neglected;
- (5) Wall thermal resistance is neglected;
- (6) The flow is fully developed:

$$\frac{u}{u_m} = 2\left[1 - \left(\frac{r}{R}\right)^2\right]; \quad v = 0, \quad u_m \text{ — Mean velocity}$$

2. Mathematical formulation (描述)

(1) Energy equation

Cylindrical coordinate, symmetric temp. distribution, and no natural convection (A4):

$$\rho c_p \left(u \frac{\partial T}{\partial x} + v \frac{\partial T}{\partial r} \right) = \frac{1}{r} \frac{\partial}{\partial r} \left(\lambda r \frac{\partial T}{\partial r} \right) + \frac{\partial}{\partial x} \left(\lambda \frac{\partial T}{\partial x} \right) + s_T$$

FD flow
(A6)

No axial
cond. (A2)

No dissipation
(A3)

$$\rho c_p u \frac{\partial T}{\partial x} = \frac{1}{r} \frac{\partial}{\partial r} \left(\lambda r \frac{\partial T}{\partial r} \right) \quad \text{Type of eq.?$$

2-D parabolic eq.!

(2) Boundary condition

$$r = 0, \frac{\partial T}{\partial r} = 0 \quad (\text{Symmetric condition}) ;$$

$$r = R, -\lambda \frac{\partial T}{\partial r} = h_e (T - T_\infty) \quad (\text{External convective condition!})$$

Internal fluid thermal conductivity

External (外部) convective heat transfer coefficient (given)

No wall thermal resistance (A5), tube outer radius = R

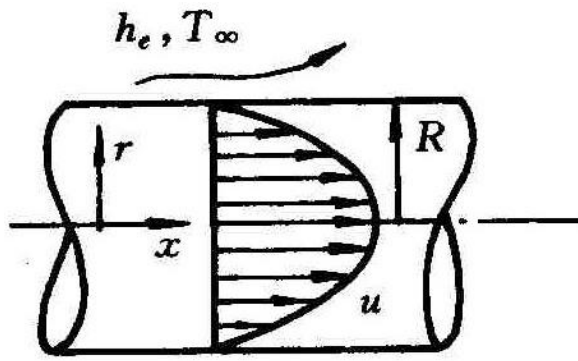

3.5.3 Governing eqs. and dimensionless forms

From fully developed condition a dimensionless temperature can be introduced, transforming the PDE to ordinary eq..

$$\text{Defining } \Theta = \frac{T - T_\infty}{T_b - T_\infty} \leftarrow \frac{T - T}{T_b - T} \leftarrow \frac{T - T}{T - T}$$

$$\text{Then: } T = \Theta(T_b - T_\infty) + T_\infty; \quad \frac{\partial T}{\partial x} = \Theta \frac{\partial T_b}{\partial x} = \Theta \frac{dT_b}{dx}$$

Defining dimensionless space and “time” coordinates:

$$\eta = \frac{r}{R}; \quad X = \frac{x}{R \bullet Pe} \quad Pe = \frac{2R \rho c_p u_m}{\lambda} = \frac{2Ru_m}{a}$$

Constant properties (A 1)

Energy eq. can be rewritten as:

$$\frac{dT_b / dX}{T_b - T_\infty} = \frac{1}{\eta} \frac{d}{d\eta} \left(\eta \frac{d\Theta}{d\eta} \right) / \left(\frac{1}{2} \Theta \frac{u}{u_m} \right) = -\Lambda \quad \boxed{\Lambda > 0}$$

Dependent on X only

Dependent on η only

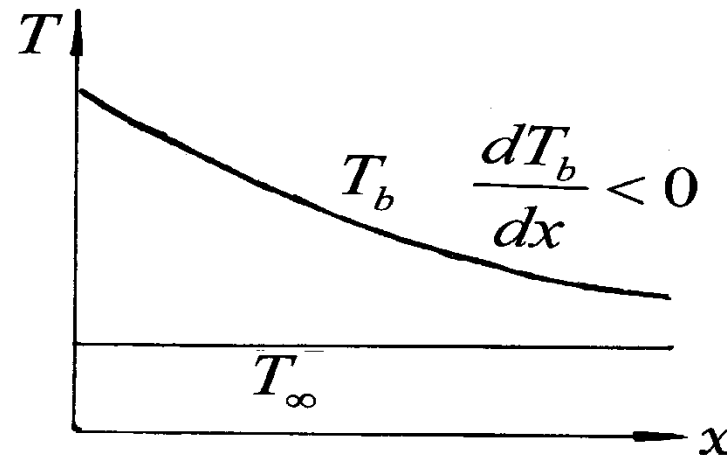
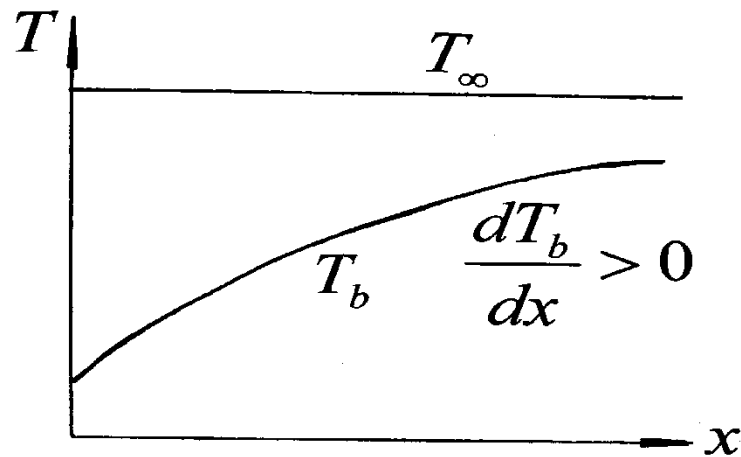

Λ is called **eigenvalue** (特征值)

Following ordinary differential equation for the dimensionless temperature can be obtained

$$\frac{1}{\eta} \frac{d}{d\eta} \left(\eta \frac{d\Theta}{d\eta} \right) / \left(\frac{1}{2} \Theta \frac{u}{u_m} \right) = -\Lambda \quad (\text{a})$$

The original two B.Cs. are transformed (转换成) into:

$$\eta = 0, \quad \frac{d\Theta}{d\eta} = 0; \quad (\text{b})$$

$$\eta = 1, \quad -\frac{d\left(\frac{T - T_\infty}{T_b - T_\infty}\right)}{d\left(\frac{r}{R}\right)} = \left(\frac{h_e R}{\lambda}\right) \frac{T - T_\infty}{T_b - T_\infty} \longrightarrow \left(\frac{d\Theta}{d\eta}\right)_{\eta=1} = -Bi\Theta_w \quad (\text{c})$$

Question: whether from Eqs. (a)-(c) a unique (唯一的) solution can be obtained?

3.5.4 Analysis of condition for unique solution

Because of the **homogeneous (齐次性)** character :

Every term in the differential equation contains a **linear part** of dependent variable or its 1st/2nd derivative.

$$\frac{1}{\eta} \frac{d}{d\eta} \left(\eta \frac{d\Theta}{d\eta} \right) / \left(\frac{1}{2} \Theta \frac{u}{u_m} \right) = -\Lambda \quad \longrightarrow \quad \frac{1}{\eta} \frac{d}{d\eta} \left(\eta \frac{d\Theta}{d\eta} \right) = -\Lambda \left(\frac{1}{2} \Theta \frac{u}{u_m} \right)$$

In addition, the given B.Cs. are also **homogeneous**:

$$\eta = 0, \quad \frac{d\Theta}{d\eta} = 0; \quad \left. \frac{d\Theta}{d\eta} \right|_{\eta=1} = -Bi\Theta_w$$

For the above mathematical formulation there exists an uncertainty (**不确定性**) of being able to be multiplied by a constant for its solution.

While in order to solve the problem, the value of Λ in the formulation has to be determined.

In order to get a unique solution and to specify the eigenvalue, we need **to supply one more condition!**

We examine the definition of dimensionless temperature:

$$\Theta_b = \left(\frac{T - T_\infty}{T_b - T_\infty} \right)_b = \frac{T_b - T_\infty}{T_b - T_\infty} \equiv \mathbf{1.0}$$

Physically, the averaged temperature is defined by

$$\Theta_b = \frac{\int_0^R 2\pi r u \Theta dr}{\pi R^2 u_m} = \underline{2 \int_0^1 \frac{r}{R} \frac{u}{u_m} \Theta d\left(\frac{r}{R}\right) = \mathbf{1}}$$

Thus the complete formulation is:

$$\frac{1}{\eta} \frac{d}{d\eta} \left(\eta \frac{d\Theta}{d\eta} \right) + \Lambda \left(\frac{1}{2} \Theta \frac{u}{u_m} \right) = 0 \quad (\text{a})$$

$$\eta = 0, \quad \frac{d\Theta}{d\eta} = 0; \quad (\text{b})$$

$$\left. \frac{d\Theta}{d\eta} \right)_{\eta=1} = -Bi\Theta_w \quad (\text{c})$$

$$\int_0^1 \eta \frac{u}{u_m} \Theta d\eta = 1/2 \quad (\text{d})$$

Non-homogeneous term!

3.5.5 Numerical solution method

$$\frac{1}{\eta} \frac{d}{d\eta} \left(\eta \frac{d\Theta}{d\eta} \right) + \Lambda \left(\frac{1}{2} \Theta \frac{u}{u_m} \right) = 0$$

This is a 1-D conduction equation with a source term!

$\frac{\Lambda}{2} \Theta \frac{u}{u_m}$, whose value should be determined during the solution process **iteratively (迭代地)**.

Patankar – Sparrow proposed following numerical solution method:

(1) Let $\Theta = \Lambda \phi$

Because of the homogeneous character, the form of the equation is not changed only replacing Θ by ϕ .

$$\frac{1}{\eta} \frac{d}{d\eta} \left(\eta \frac{d\phi}{d\eta} \right) + \Lambda \left(\frac{1}{2} \phi \frac{u}{u_m} \right) = 0 \quad (\text{a})$$

$$\eta = 0, \frac{d\phi}{d\eta} = 0; \quad (\text{b})$$

$$\left. \frac{d\phi}{d\eta} \right|_{\eta=1} = -Bi\phi_w \quad (\text{c})$$

$$\int_0^1 \eta \frac{u}{u_m} \Lambda \phi d\eta = 1/2 \quad (\text{d}) \longrightarrow$$

Non-homogeneous equ.

$\Lambda = 1 / \left(2 \int_0^1 \eta \frac{u}{u_m} \phi d\eta \right)$ It can be used to iteratively
 determine the **eigenvalue**.

- (2) Assuming an initial field ϕ^* , to get Λ^*
- (3) Solving an ordinary differential eq. with a source term to get an improved ϕ
- (4) Repeating the above procedure until

$$\left| \frac{\phi^* - \phi}{\phi} \right| \leq \varepsilon,$$

$$\varepsilon = 10^{-3} \sim 10^{-6}$$

This iterative procedure is easy to approach convergence:

$$S = \Lambda \frac{1}{2} \frac{u}{u_m} \phi = \frac{(u/u_m)\phi}{4 \int_0^1 \eta (u/u_m) \phi d\eta} = \frac{(1-\eta^2)\phi}{4 \int_0^1 \eta (1-\eta^2) \phi d\eta}$$

$$\Lambda = 1 / \left(2 \int_0^1 \eta \frac{u}{u_m} \phi d\eta \right)$$

ϕ exists in both numerator and denominator, thus only the distribution, rather than absolute value will affect the source term.

3.5.6 Treatment of numerical results

Two ways for obtaining heat transfer coefficient:

1. From solved temp. distribution using Fourier's law of heat conduction and Newton's law of cooling:

$$r = R, -\lambda \frac{\partial T}{\partial r} = h(T_w - T_b) \longrightarrow h = -\lambda \left(\frac{\partial T}{\partial r} \right)_{r=R} \frac{1}{T_w - T_b}$$

For inner fluid

Note: different from Boundary condition

$$r = R, -\lambda \frac{\partial T}{\partial r} = h_e (T - T_\infty)$$

2. From the eigenvalue (特征值) :

From heat balance between inner and external heat transfer

$$h(T_b - T_w) = h_e(T_w - T_\infty)$$

Inner

External

Get:

$$\begin{aligned}
 h = h_e \frac{T_w - T_\infty}{T_b - T_w} &\rightarrow h = h_e \frac{1}{\frac{T_b - T_w}{T_w - T_\infty}} \rightarrow \frac{h_e}{\frac{T_b - T_\infty + T_\infty - T_w}{T_w - T_\infty}} \\
 \rightarrow \frac{h_e}{\frac{T_b - T_\infty}{T_w - T_\infty} - 1} &\rightarrow h = \frac{h_e}{\frac{1}{\frac{T_w - T_\infty}{T_b - T_\infty}} - 1} = \frac{h_e}{\frac{1}{\Theta_w} - 1} \rightarrow
 \end{aligned}$$

$$h = \frac{h_e}{\frac{1}{\Theta_w} - 1} = \frac{h_e \Theta_w}{1 - \Theta_w} = \frac{h_e \Lambda \phi_w}{1 - \Lambda \phi_w}$$

$$Nu = \frac{2Rh}{\lambda} = \frac{2R}{\lambda} \frac{h_e \Lambda \phi_w}{1 - \Lambda \phi_w} = \frac{2Bi \Lambda \phi_w}{1 - \Lambda \phi_w}$$

From the specified values Bi , the corresponding eigenvalues, Λ , can be obtained. Thus it is not necessary to find the 1st-order derivative at the wall of function ϕ for determining Nusselt number.

3.5.7 Discussion on numerical results

Table : Numerical results of FDHT in tubes
 In the textbook: Table 4-6

Bi	Λ	Nu
0	0	4.364
0.1	0.381 8	4.330
0.25	0.894 3	4.284
0.5	1.615	4.221
1	2.690	4.122
2	3.995	3.997
5	5.547	3.840
10	6.326	3.758
100	7.195	3.663
∞	7.314	3.657

$(Nu)_q$
 $(Nu)_T$

1. *Bi* effect:

From definition $Bi = \frac{Rh_e}{\lambda}$

$Bi \rightarrow \infty, h_e \rightarrow \infty$ External heat transfer is very strong, the wall temp. approaches fluid temp. This is corresponding to constant wall temp condition, thus

$$Nu = 3.66$$

$Bi \rightarrow 0, h_e \rightarrow 0$ Is this adiabatic? No!

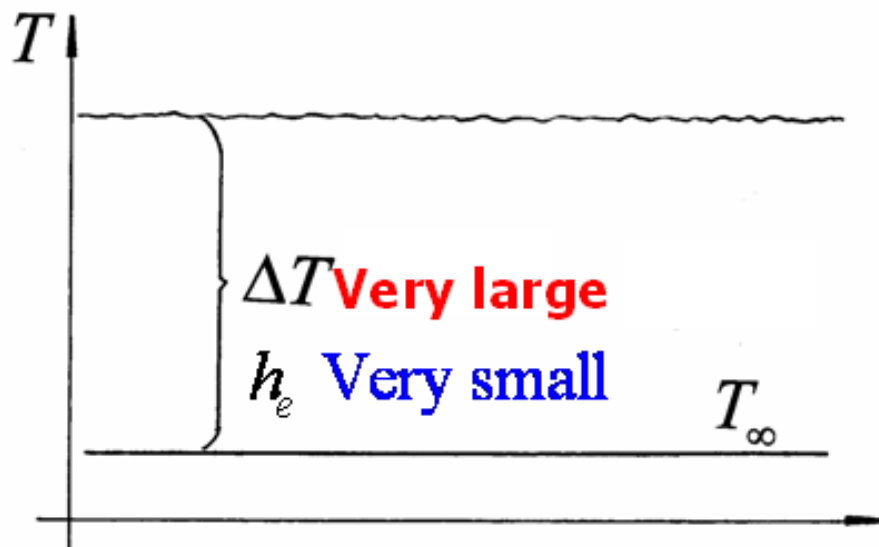

Product of very small HT coefficient and very large temp. difference makes heat flux almost constant.

$$q = h_e \Delta T \approx const$$

2. Computer implementation of $Bi \rightarrow \infty$ and $Bi = 0$

$Bi \longrightarrow \infty$ by progressively (逐渐地) increasing Bi :

$$Bi = 10^5, 10^6, 10^7, \dots$$

$Bi = 0$ by progressively decreasing Bi :

$$Bi = 0.1, 0.01, 0.001, 0.0001, 0.00001, \dots$$

Double decision (双精度) must be used for the computation:

$$Nu = \frac{2Bi\Lambda\phi_w}{1 - \Lambda\phi_w}, \quad Bi \rightarrow 0, \Lambda \rightarrow 0, \Lambda\phi_w \rightarrow 1 \quad \longrightarrow \quad \frac{0}{0}$$

4.6 Fully Developed HT in Rectangle Ducts

4.6.1 Physical and mathematical models

4.6.2 Governing eqs. and their dimensionless forms

4.6.3 Condition for unique solution

4.6.4 Treatment of numerical results

4.6.5 Other cases

3.6 Fully Developed HT in Rectangle Ducts

3.6.1 Physical and mathematical models

Fluid with constant properties flows in a long rectangle duct with a constant wall temp. **Determine the friction factor and HT coefficient in the fully developed region for laminar flow.**

1. Momentum equation

For the fully developed flow $u=v=0$, only the velocity component in z-direction is not zero. Its governing equation:

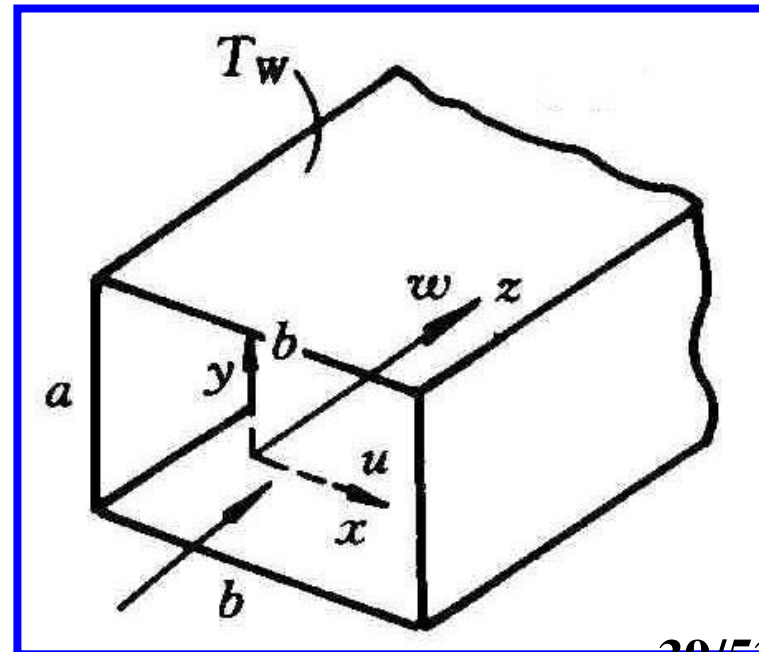

$$\rho \left(\cancel{u} \frac{\partial w}{\partial x} + \cancel{v} \frac{\partial w}{\partial y} + \cancel{w} \frac{\partial w}{\partial z} \right) = -\frac{\partial p}{\partial z} + \eta \left(\frac{\partial^2 w}{\partial x^2} + \frac{\partial^2 w}{\partial y^2} + \frac{\partial^2 w}{\partial z^2} \right)$$

$$\eta \left(\frac{\partial^2 w}{\partial x^2} + \frac{\partial^2 w}{\partial y^2} \right) - \frac{\partial p}{\partial z} = 0$$

Neglecting cross section variation of p

$$\eta \left(\frac{\partial^2 w}{\partial x^2} + \frac{\partial^2 w}{\partial y^2} \right) - \frac{dp}{dz} = 0$$

Taking 1/4 region as the computational domain because of symmetry. Boundary conditions are:

At the wall, $w=0$;

At center line,

First order normal derivative equals zero:

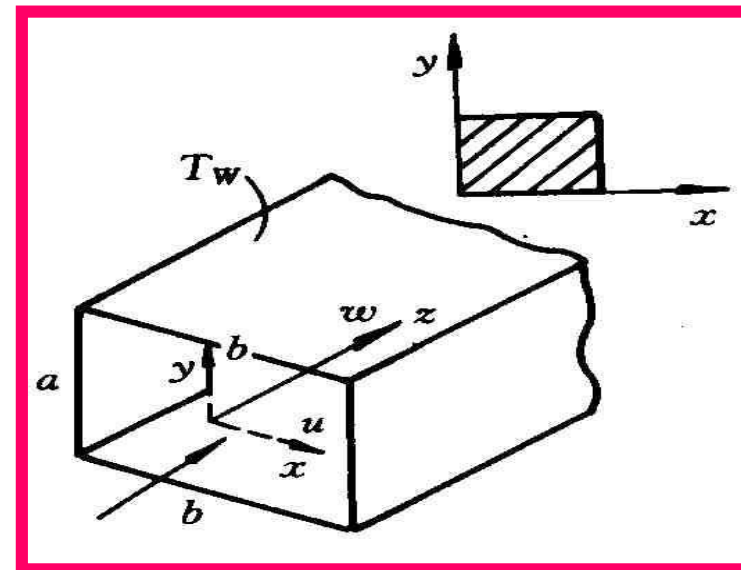
$$\frac{\partial w}{\partial n} = 0$$

Defining a dimensionless velocity as :

$$W = \frac{\eta w}{-D^2 \frac{dp}{dz}}$$

where D is the referenced length, say: $D = a$, or $D = b$.

Defining dimensionless coordinates: $X = x/D$, $Y = y/D$, then:

$$\eta \left(\frac{\partial^2 w}{\partial x^2} + \frac{\partial^2 w}{\partial y^2} \right) - \frac{dp}{dz} = 0 \rightarrow \begin{cases} \frac{\partial^2 W}{\partial X^2} + \frac{\partial^2 W}{\partial Y^2} + 1 = 0 \\ \text{At wall, } W = 0; \\ \text{At center lines, } \frac{\partial W}{\partial n} = 0 \end{cases}$$

It is a heat conduction problem with a source

term and a constant diffusivity η !

2. Energy equation

$$\rho c_p \left(\cancel{\mu \frac{\partial T}{\partial x}} + \cancel{\nu \frac{\partial T}{\partial y}} + w \frac{\partial T}{\partial z} \right) = \frac{\partial}{\partial x} \left(\lambda \frac{\partial T}{\partial x} \right) + \frac{\partial}{\partial y} \left(\lambda \frac{\partial T}{\partial y} \right) + \frac{\partial}{\partial z} \left(\lambda \cancel{\frac{\partial T}{\partial z}} \right)$$

Thus:
$$\rho c_p w \frac{\partial T}{\partial z} = \frac{\partial}{\partial x} \left(\lambda \frac{\partial T}{\partial x} \right) + \frac{\partial}{\partial y} \left(\lambda \frac{\partial T}{\partial y} \right)$$

Neglecting axial
heat conduction

Type of equation? Parabolic! Z is a one-way
coordinate like time!

Boundary conditions:

At the wall, $T = T_w$;

At the center line, $\frac{\partial T}{\partial n} = 0$

3.6.2 Dimensionless governing equation

We should define an appropriate dimensionless temperature such that the dimension of the problem can be reduced from 3 to 2: Separating the one-way coordinate z from the two-way coordinates x, y .

$$\Theta = \frac{T_w - T}{T_w - T_b} \quad \leftarrow \quad \frac{T - T_b}{T_w - T_b} \quad \leftarrow \quad \frac{T - T_b}{T_w - T_b}$$

Then $T = \Theta(T_b - T_w) + T_w$

$$\frac{\partial T}{\partial z} = \Theta \frac{\partial (T_b - T_w)}{\partial z}$$

$$Pe = \frac{\rho c_p w_m D}{\lambda}$$

Defining: $X = x/D, Y = y/D, Z = z/(DPe)$

One-way coordinate!

Dimensionless governing eq.

$$\frac{\partial(T_b - T_w)}{\partial Z} \frac{1}{T_b - T_w} = \frac{\frac{\partial^2 \Theta}{\partial X^2} + \frac{\partial^2 \Theta}{\partial Y^2}}{\frac{W}{W_m} \Theta} = -\Lambda$$

$$\Lambda > 0$$

Dependent on Z only

Dependent on X, Y only

Thus:

$$\frac{\partial^2 \Theta}{\partial X^2} + \frac{\partial^2 \Theta}{\partial Y^2} + \Lambda \frac{W}{W_m} \Theta = 0;$$

$$\frac{d(T_b - T_w)}{dZ} \frac{1}{T_b - T_w} = -\Lambda$$

At the wall $\Theta = 0$

At center line, $\frac{\partial \Theta}{\partial n} = 0$

Heat conduction with an inner source!

3.6.3 Analysis on the unique solution condition

Because of the homogeneous character, these also exists an uncertainty of being magnifying by any times!

Introducing average temperature (difference):

$$T_w - T_b = \frac{\int_A (T_w - T) w dA}{\int w dA} \longrightarrow \frac{T_w - T_b}{T_w - T_b} = \frac{\int_A \frac{T_w - T}{T_w - T_b} w dA}{w_m A}$$

$$1 = \frac{1}{A} \int_A \frac{T_w - T}{T_w - T_b} \frac{w}{w_m} dA \longrightarrow 1 = \frac{1}{A} \int_A \Theta \left(\frac{W}{W_m} \right) dA$$

It is the additional condition for the unique solution.

Numerical solution method is the same as that for a circular tube.

3.6.4 Treatment of numerical results

After receiving converged velocity and temperature fields, friction factor and Nusselt number can be obtained as follows:

1. fRe — for laminar problems $fRe = \text{constant}$:

$$f Re = \left[-\frac{D_e}{1} \frac{dp}{dz} \right] \left(\frac{w_m D_e}{\nu} \right) \xrightarrow{\substack{\text{Definition} \\ \text{of } W}} f Re = \frac{2}{W_m} \left(\frac{D_e}{D} \right)^2$$

$$W = \frac{\eta w}{-D^2 \frac{dp}{dz}}$$

2. Nu — Making an energy balance :

$$\rho c_p w_m A \frac{dT_b}{dz} = qP, P \text{ is the duct circumference length}$$

$$\frac{d(T_b - T_w)}{dZ} \frac{1}{T_b - T_w} = -\Lambda \quad \text{i.e.,} \quad \frac{dT_b}{dZ} = \frac{dT_b}{dz} DPe = (T_w - T_b)\Lambda$$

$$\frac{dT_b}{dz} = \frac{1}{DPe} (T_w - T_b)\Lambda$$

Substituting in $\rho c_p w_m A \frac{dT_b}{dz} = qP$

yields $q = \frac{A \rho c_p w_m}{P} \frac{dT_b}{dz} = \frac{A \rho c_p w_m}{P} \frac{1}{DPe} \Lambda (T_w - T_b)$

yields: $q = \frac{A \lambda}{P D^2} \Lambda (T_w - T_b)$

$Pe = \frac{\rho c_p w_m D}{\lambda}$

$$Nu = \frac{hD_e}{\lambda} = \frac{q}{T_w - T_b} \frac{D_e}{\lambda} = \frac{1}{T_w - T_b} \frac{D_e}{\lambda} \frac{A \lambda}{P D^2} \Lambda (T_w - T_b)$$

$$Nu = \frac{1}{4} \left(\frac{D_e}{D} \right)^2 \Lambda \quad f Re = \frac{2}{W_m} \left(\frac{D_e}{D} \right)^2$$

$$D_e = \frac{4A}{P}$$

3.6.5 Other cases

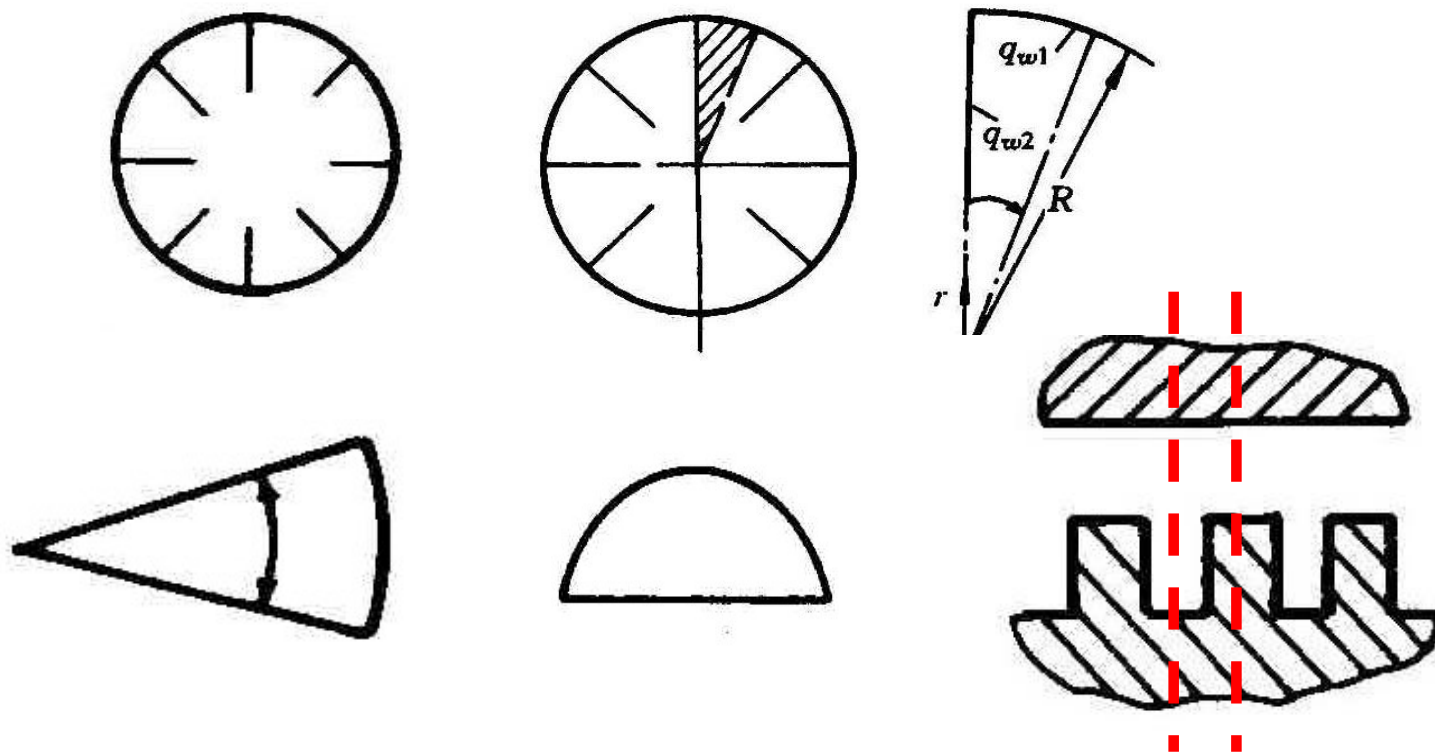



Home Work No.2

4-2 ($T_1=150, T_f=25$),

4-4,

4-12,

4-14,

4-18

Due in October 8

Problem 4-2

As shown in Fig. 4-22, in 1-D steady heat conduction problem, known conditions are: $T_1=150$, $\lambda=5$, $S=150$, $T_f=25$, $h=15$, the units in every term are consistent. Try to determine the values of T_2, T_3 ; Prove that the solution meet the overall conservation requirement even though only three nodes are used.

Problem 4-4

A large plate with thickness of 0.1 m, uniform source $S=50 \times 10^3 \text{ W/m}^3$, $\lambda = 10 \text{ W / (m} \cdot \text{° C)}$; One of its wall is kept at 75°C , while the other wall is cooled by a fluid with $T_f = 25^\circ \text{C}$ and heat transfer coefficient $h = 50 \text{ W/m}^2 \cdot \text{° C}$

Adopt Practice B, divide the plate thickness into three uniform CVs, determine the inner node temperature. Take 2nd order accuracy for the inner node, adopt the additional source term method for the right boundary node.

Problem 4-12:

Write a program using TDMA algorithm, and use the following method to check its correctness: set arbitrary values of the coefficients A_i , B_i , and C_i ($i=1,10$) with $B_1=0$, and $C_{10}=0$. Then setting some reasonable values of temperatures T_1, \dots, T_{10} , calculate the corresponding constants D_i . Apply your program for solving T_i by using the values of A_i , B_i , C_i and D_i , and compare the results with the given temperature values.

Problem 4-14:

According problem discussed in Section 4.6 (the fully developed heat convection in a circular tube), try to analyze the following three dimensionless temperature definitions of THEATA:

$$\Theta_1 = \frac{T - T_w}{T_b - T_w} \quad \Theta_2 = \frac{T - T_\infty}{T_w - T_\infty} \quad \Theta_3 = \frac{T - T_w}{T_\infty - T_w}$$

which one is acceptable for separation of variables.

Problem 4-18:

Shown in Fig.4-25 is a laminar fully developed heat transfer in a duct of half circular cross. Try:

- (1) Write the mathematical formulation of the heat transfer problem;
- (2) Make the formulation dimensionless by introducing some dimensionless parameters;
- (3) Derive the expressions for fRe and Nu from numerical solutions, where the characteristic length for Re and Nu is the equivalent diameter D_e .

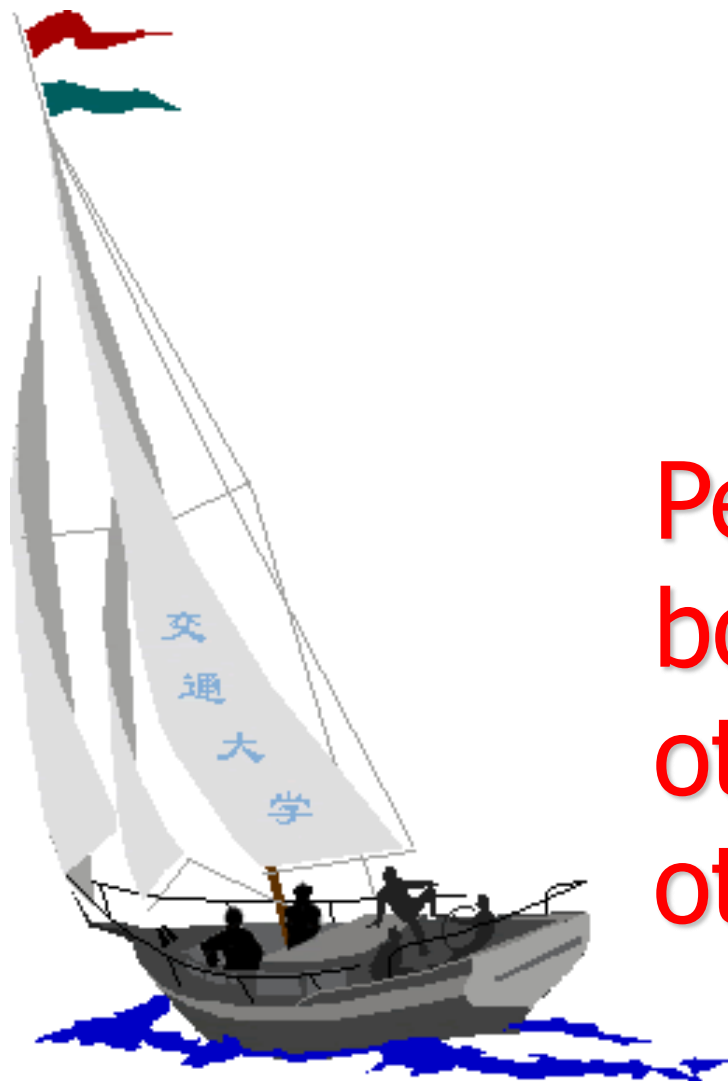

同舟共济 渡彼岸!

People in the same
boat help each
other to cross to the
other bank, where....